





Magnetic Rodless Cylinder

Series **CY1**



Magnetically coupled cylinders save space and have a wide range of applications

Series CY1B/CY1R/CY1S/CY1L/CY1H Model Selection Criteria

Model Selection Criteria	Recommended cylinder			
	Appearance	Features		
<ul style="list-style-type: none"> When used with many different types of guides. When a long stroke is necessary. 	Non-integrated guide types	Series CY1B Size: $\phi 6$, $\phi 10$, $\phi 15$, $\phi 20$, $\phi 25$, $\phi 32$, $\phi 40$, $\phi 50$, $\phi 63$ 	<ul style="list-style-type: none"> A long stroke is possible. Wide variations from $\phi 6$ to $\phi 63$. 	
		Series CY1R Size: $\phi 6$, $\phi 10$, $\phi 15$, $\phi 20$, $\phi 25$, $\phi 32$, $\phi 40$, $\phi 50$, $\phi 63$ 		<ul style="list-style-type: none"> Cylinder can be directly mounted. Auto switches can be mounted, and there is no lurching from cylinder. Turning can be stopped within an allowable range. Piping can be concentrated with the centralized piping type. External dimensions are compact. Mounting can be performed on the top body surface or on one side surface.
<ul style="list-style-type: none"> To ensure a permanent path. When used for general transporting. 	Integrated guide types	Series CY1S Size: $\phi 6$, $\phi 10$, $\phi 15$, $\phi 20$, $\phi 25$, $\phi 32$, $\phi 40$ 	<ul style="list-style-type: none"> A load can be carried directly by the integrated guide type. The centralized piping type allows concentration of piping on one side plate. Auto switches can be mounted. Impact at the stroke end is absorbed by inclusion of a shock absorber. 	
		Series CY1L Size: $\phi 6$, $\phi 10$, $\phi 15$, $\phi 20$, $\phi 25$, $\phi 32$, $\phi 40$ 		<ul style="list-style-type: none"> Stable operation is possible even with an eccentric load, through the use of a ball bushing.
		Series CY1H Size: $\phi 10$, $\phi 15$, $\phi 20$, $\phi 25$, $\phi 32$ 		<ul style="list-style-type: none"> The use of a linear guide makes possible a large load, large moment and high precision. Mounting freedom is improved by providing T-slots on the mounting surfaces A top cover is mounted over the sliding section of the cylinder to prevent scratches and damage, etc.
<ul style="list-style-type: none"> To ensure a permanent path. When smoother operation is required even with an eccentric load. 				
<ul style="list-style-type: none"> To ensure a permanent path. When a larger load, larger moment or higher precision are required. When used for picking and placing, etc. (Application Example 2) 				

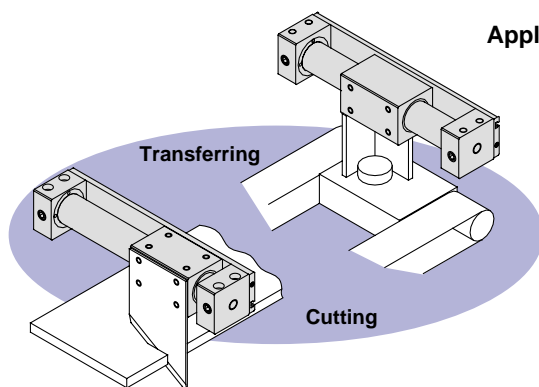

Application Example 1

Application examples

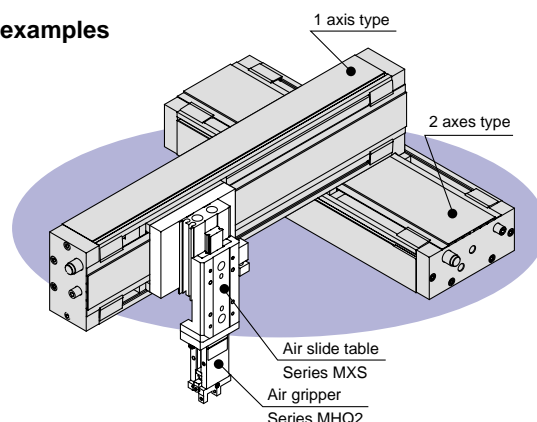

Application Example 2

Series CY1B

Basic Type



How to Order

Basic type

CY1B **25** **H** **300**

Basic type

Bore size

6	6mm
10	10mm
15	15mm
20	20mm
25	25mm
32	32mm
40	40mm
50	50mm
63	63mm

Standard stroke

Refer to the standard stroke table below.

Magnetic holding force

Refer to the magnet holding force table below.

Standard Stroke Table

Bore size (mm)	Standard stroke (mm)	Maximum available stroke (mm) ^{Note)}
6	50, 100, 150, 200	300
10	50, 100, 150, 200, 250, 300	500
15	50, 100, 150, 200, 250, 300, 350 400, 450, 500	1000
20	100, 150, 200, 250, 300, 350, 400, 450 500, 600, 700, 800	2000
25		4000
32		
40	100, 150, 200, 250, 300, 350, 400, 450 500, 600, 700, 800, 900, 1000	5000
50		6000
63		

Note) Contact SMC if the maximum stroke will be exceeded.

Magnetic Holding Force (N)

1N: Approx. 0.102kgf

Bore size (mm)		6	10	15	20	25	32	40	50	63
Holding force type	H type	19.6	53.9	137	231	363	588	922	1471	2256
	L type	–	–	81.4	154	221	358	569	863	1373

Series CY1B



Strong holding force

H type/ø63 --- 2256 N
L type/ø63 --- 1373 N

Available up to 6000mm stroke
(ø50, ø63)

Long life with no external leakage

JIS symbol

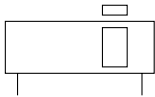

Mounting bracket type

- When mounting a floating bracket to a Series CY1B body, refer to P.67 for details, as this will be an order made product.

Specifications

1MPa: Approx. 10.2kgf/cm²

Fluid	Air
Proof pressure	1.05MPa {10.7kgf/cm ² }
Max. operating pressure	0.7MPa {7.1kgf/cm ² }
Min. operating pressure	0.18MPa {1.8kgf/cm ² }
Ambient & fluid temperature	-10 to 60°C
Piston speed	50 to 400mm/s
Cushion	Rubber bumpers at both ends
Lubrication	Non-lube
Stroke length tolerance	0 to 250st: $^{+1.0}_0$, 251 to 1000st: $^{+1.4}_0$, 1001st & up: $^{+1.8}_0$
Mounting orientation	Unrestricted
Mounting nuts (2pcs.)	Standard equipment (accessory)

⚠ Caution

When calculating the actual thrust, design should consider the minimum actuating pressure.

Theoretical Cylinder Thrust

ø6, ø10

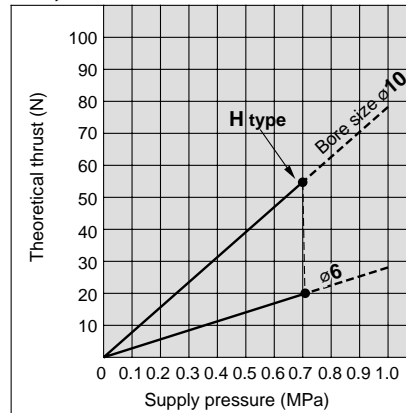

ø15, ø20, ø25, ø32, ø40

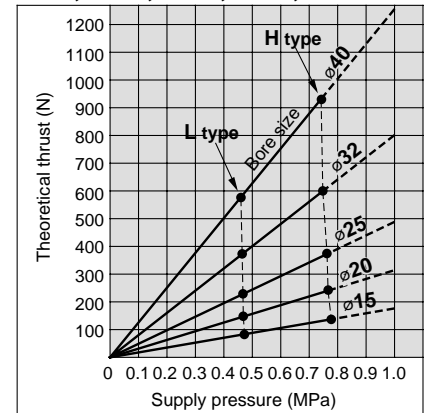

ø50, ø63

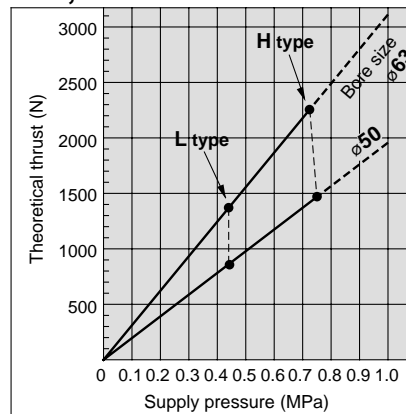

Weight Table

		Bore size (mm)									kg
Magnet holding force		6	10	15	20	25	32	40	50	63	
Basic weight	CY1B□H	0.075	0.08	0.28	0.37	0.71	1.34	2.15	3.4	5.7	
	CY1B□L	—	—	0.22	0.26	0.62	1.19	1.97	3.1	5.2	
Additional weight per 50mm of stroke		0.004	0.014	0.02	0.04	0.05	0.07	0.08	0.095	0.12	

Calculation method/Example: CY1B32H-500

Basic weight 1.34kg
Additional weight 0.07/50s
Cylinder stroke 500st } 1.34 + 0.07 x 500 ÷ 50 = 2.04kg

Principal Materials

Description	Material	Note
Head cover	Aluminum alloy	Kanigen plated
Cylinder tube	Stainless steel	Hard anodized
Body	Aluminum alloy	
Magnet	Rare earth	

Series CY1B Model Selection Method 1

E: Kinetic energy of load (J)

$$E = \frac{(W + W_B)}{2} \times \left(\frac{V}{1000}\right)^2$$

Es: Allowable kinetic energy for intermediate stop using an air pressure circuit (J)

Fn: Allowable driving force (N)

Ps: Operating pressure limit for intermediate stop using an external stopper, etc. (MPa)

Pv: Maximum operating pressure for vertical operation (MPa)

WBmax: Maximum connection fitting weight (kg)

Wv: Allowable load weight for vertical operation (kg)

Operating conditions

- W: Load weight (kg)
- P: Operating pressure (MPa)
- W_B: Connection fitting weight (kg)
- V: Speed (mm/s)
- μ: Guide's coefficient of friction
- Stroke (mm)
- L_o: Distance from cylinder shaft center to work piece point of application (cm)
- Mode of operation (horizontal, inclined, vertical)

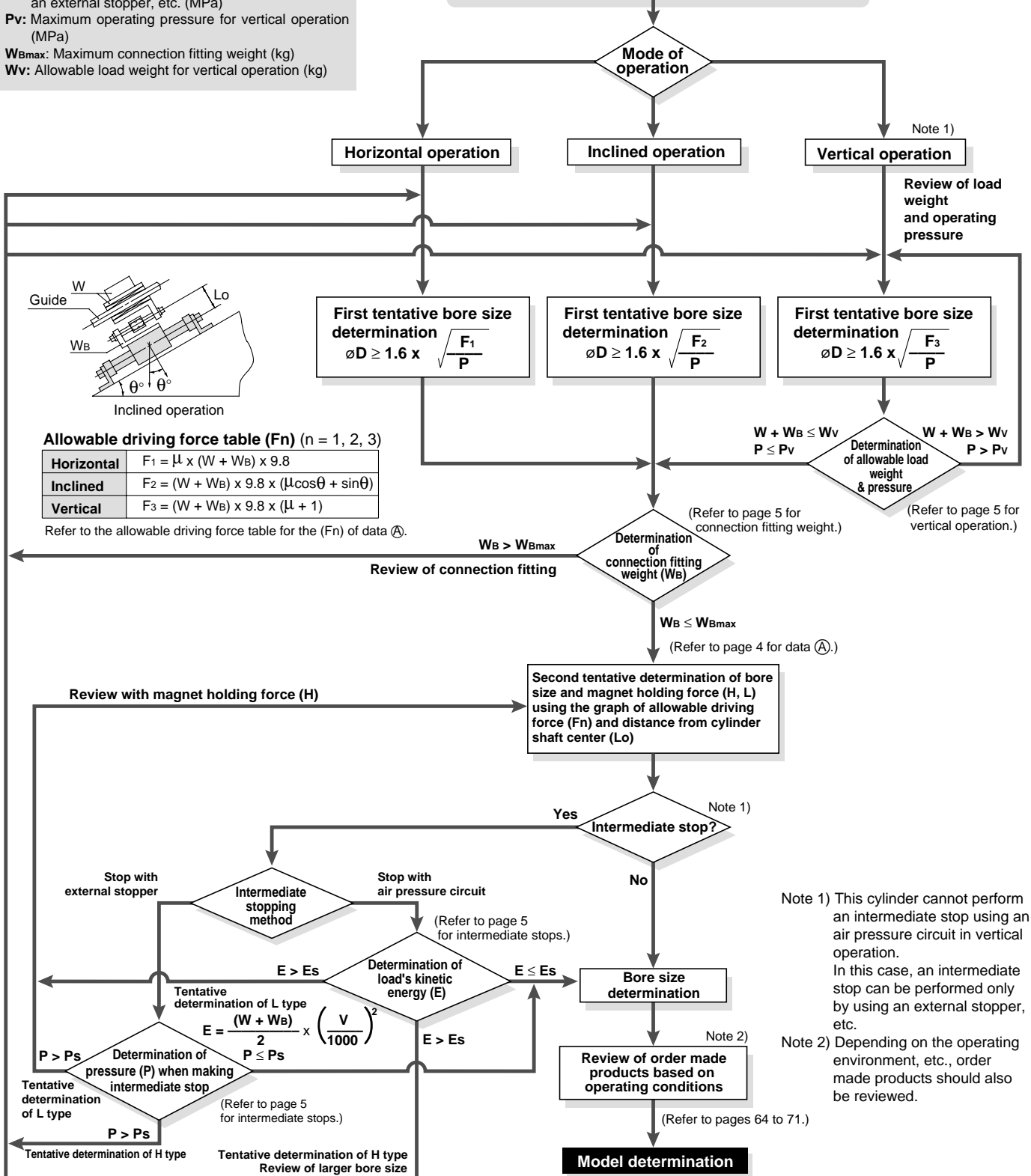

Note 1)

Review of load weight and operating pressure

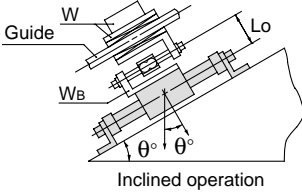

Inclined operation

$W + W_B \leq W_v$
 $P \leq P_v$

$W + W_B > W_v$
 $P > P_v$

(Refer to page 5 for connection fitting weight.)

(Refer to page 5 for vertical operation.)

(Refer to page 4 for data (A).)

Note 1)

(Refer to page 5 for intermediate stops.)

(Refer to page 5 for intermediate stops.)

Note 2)

(Refer to pages 64 to 71.)

Note 1) This cylinder cannot perform an intermediate stop using an air pressure circuit in vertical operation.

In this case, an intermediate stop can be performed only by using an external stopper, etc.

Note 2) Depending on the operating environment, etc., order made products should also be reviewed.

Series CY1B

Model Selection Method 2

Precautions on Design (1)

Selection Method

Selection procedure

1. Find the drive resisting force F_n (N) when moving the load horizontally.
2. Find the distance L_o (cm) from the point of the load where driving force is applied, to the center of the cylinder shaft.
3. Select the bore size and type of magnet holding force (types H, L) from L_o and F_n based on data ①.

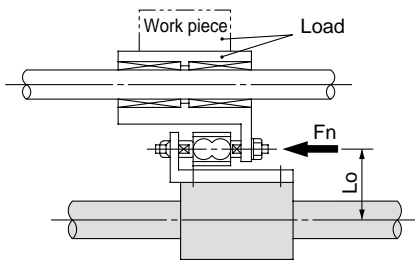

Selection example

Given a load drive resisting force of $F_n = 100$ (N) and a distance from the cylinder shaft center to the load application point of $L_o = 8$ cm, find the intersection point by extending upward from the horizontal axis of data ① where the distance from the shaft center is 8 cm, and then extending to the side, find the allowable driving force on the vertical axis.

Models suitable to satisfy the requirement of 100 (N) are **CY1B32H** or **CY1B40H**, **CY1B40L**.

<Data ①: Distance from cylinder shaft center — Allowable driving capacity>

CY1B6

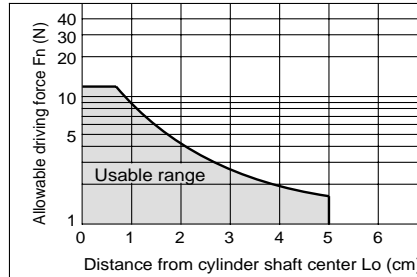

CY1B32

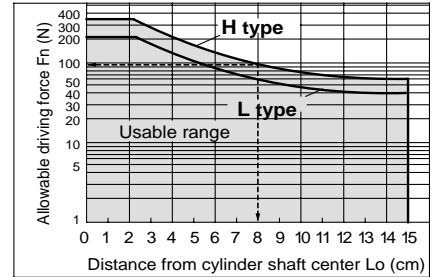

CY1B10

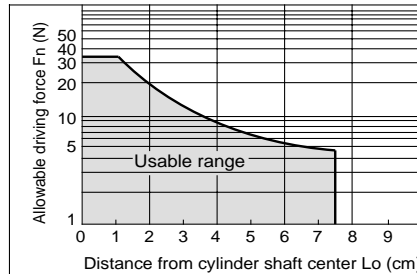

CY1B40

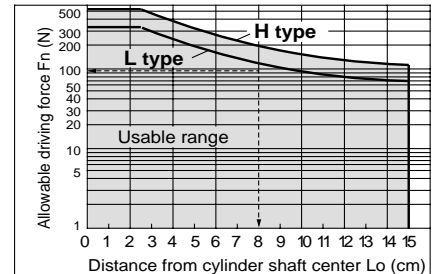

CY1B15

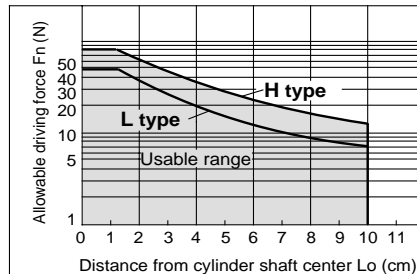

CY1B50

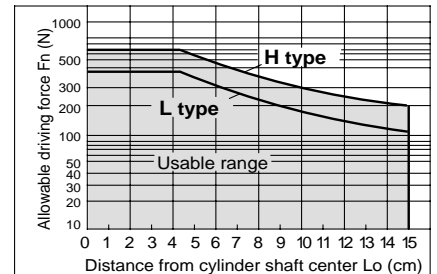

CY1B20

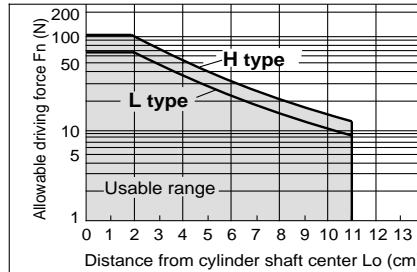

CY1B63

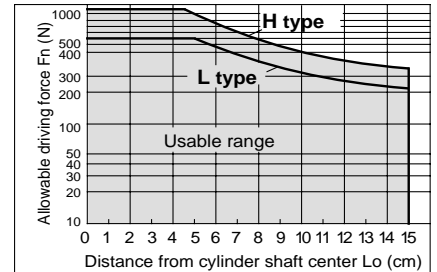

CY1B25

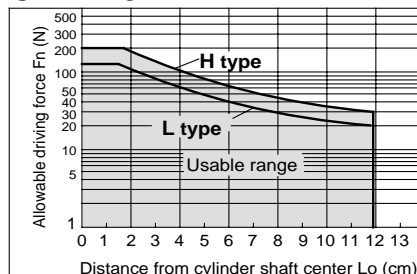

Series CY1B

Model Selection Method 3

Precautions on Design (2)

Cylinder Dead Weight Deflection

When the cylinder is mounted horizontally, deflection appears due to its own weight as shown in the data, and the longer the stroke is, the greater the amount of variation in the shaft center.

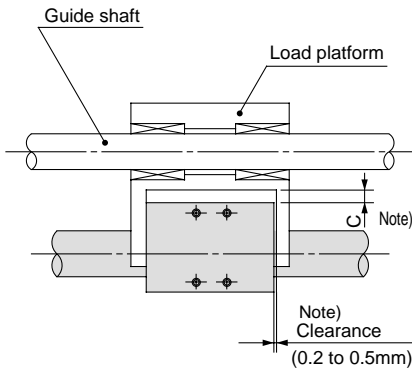

(Note) Referring to the self weight deflection in the figure below, provide clearance so that the cylinder does not touch the mounting surface or the load section, and is able to operate smoothly within the minimum operating pressure range for a full stroke.

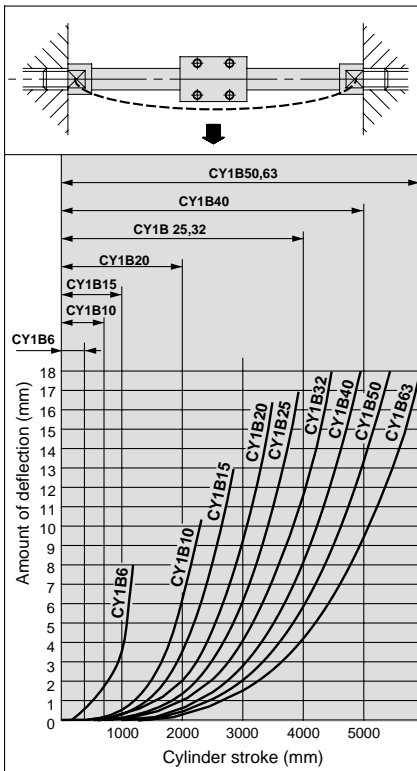

* The above deflection data indicate values when the external slider has moved to the middle of the stroke.

Vertical Operation

The load should be guided by a ball type bearing (LM guide, etc.). If a slide bearing is used, sliding resistance increases due to the load weight and load moment, which can cause malfunction.

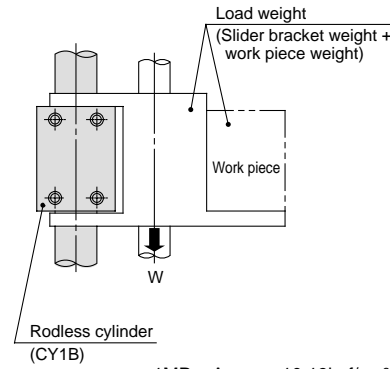

1MPa: Approx. 10.19kgf/cm²

Cylinder bore size (mm)	Model	Allowable load weight (Wv) (kg)	Max. operating pressure (Pv) (MPa)
6	CY1B 6H	1.0	0.55
10	CY1B10H	2.7	0.55
15	CY1B15H	7.0	0.65
	CY1B15L	4.1	0.40
20	CY1B20H	11.0	0.65
	CY1B20L	7.0	0.40
25	CY1B25H	18.5	0.65
	CY1B25L	11.2	0.40
32	CY1B32H	30.0	0.65
	CY1B32L	18.2	0.40
40	CY1B40H	47.0	0.65
	CY1B40L	29.0	0.40
50	CY1B50H	75.0	0.65
	CY1B50L	44.0	0.40
63	CY1B63H	115.0	0.65
	CY1B63L	70.0	0.40

(Note) Use caution, as operation above the maximum operating pressure can result in breaking of the magnetic coupling.

Max. Connection Fitting Weight

The CY1B (basic type) is not directly connected to the load, and is guided by another shaft (LM guide, etc.). Load connection fittings should be designed so that they do not exceed the weights given in the table below. (Refer to the separate instruction manual for the connection method.)

Maximum connection fitting weight

Model	Max. connection fitting weight (W _{Bmax})(kg)
CY1B 6H	0.2
10H	0.4
15□	1.0
20□	1.1
25□	1.2
32□	1.5
40□	2.0
50□	2.5
63□	3.0

Contact SMC before using fittings which exceed the above weights.

Intermediate Stops

(1) Intermediate stopping of load with an external stopper, etc.

When stopping a load in mid-stroke using an external stopper, etc., operate within the operating pressure limits shown in the table below. Use caution, as operation at a pressure exceeding these limits can result in breaking of the magnetic coupling.

1MPa: Approx. 10.19kgf/cm²

Bore size (mm)	Model	Operating pressure limit for intermediate stop (Ps)(MPa)
6	CY1B 6H	0.55
10	CY1B10H	0.55
15	CY1B15H	0.65
	CY1B15L	0.40
20	CY1B20H	0.65
	CY1B20L	0.40
25	CY1B25H	0.65
	CY1B25L	0.40
32	CY1B32H	0.65
	CY1B32L	0.40
40	CY1B40H	0.65
	CY1B40L	0.40
50	CY1B50H	0.65
	CY1B50L	0.40
63	CY1B63H	0.65
	CY1B63L	0.40

(2) Intermediate stopping of load with an air pressure circuit

When performing an intermediate stop of a load using an air pressure circuit, operate within the kinetic energy limits shown in the table below. Use caution, as operation when exceeding the allowable value can result in breaking of the magnetic coupling.

(Reference values)

Bore size (mm)	Model	Allowable kinetic energy for intermediate stop (Es)(J)
6	CY1B 6H	0.007
10	CY1B10H	0.03
15	CY1B15H	0.13
	CY1B15L	0.076
20	CY1B20H	0.24
	CY1B20L	0.16
25	CY1B25H	0.45
	CY1B25L	0.27
32	CY1B32H	0.88
	CY1B32L	0.53
40	CY1B40H	1.53
	CY1B40L	0.95
50	CY1B50H	3.12
	CY1B50L	1.83
63	CY1B63H	5.07
	CY1B63L	3.09

Series CY1B

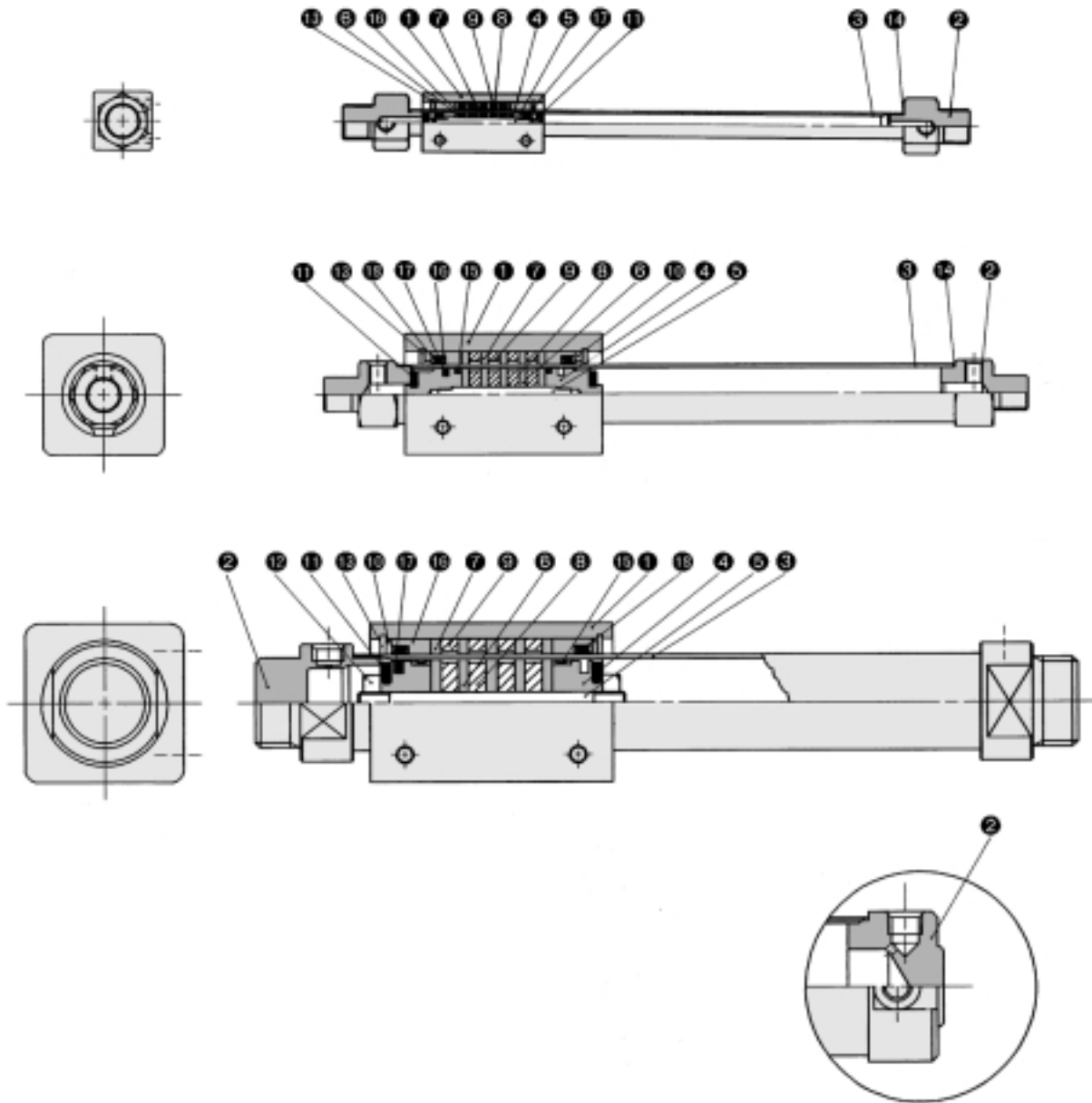

Dimensions 

Basic type

CY1B6, 10, 15

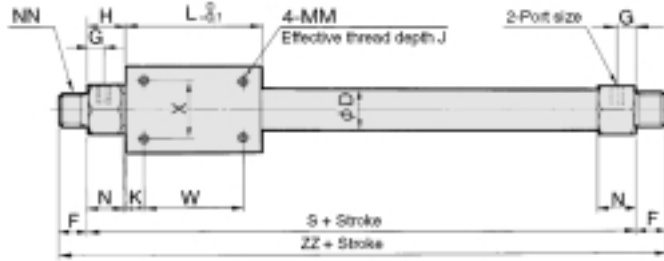
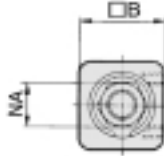

Model	Port size	D	B	F	G	H	K	L	N	NA	MM x J	NN	S	W	X	ZZ
CY1B6	M5 x 0.8	7.6	17	9	5	14	5	35	10	14	M3 x 0.5 x 4.5	M10 x 1.0	63	25	10	81
CY1B10	M5 x 0.8	12	25	9	5	12.5	4	38	11	14	M3 x 0.5 x 4.5	M10 x 1.0	63	30	16	81
CY1B15	M5 x 0.8	17	35	10	5.5	13	11	57	11	17	M4 x 0.7 x 6	M10 x 1.0	83	35	19	103

(mm)

CY1B20 to 40

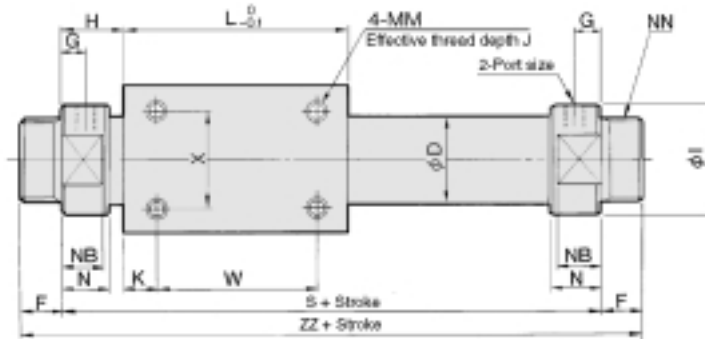
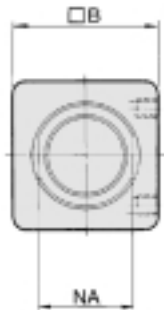

CY1B50, 63

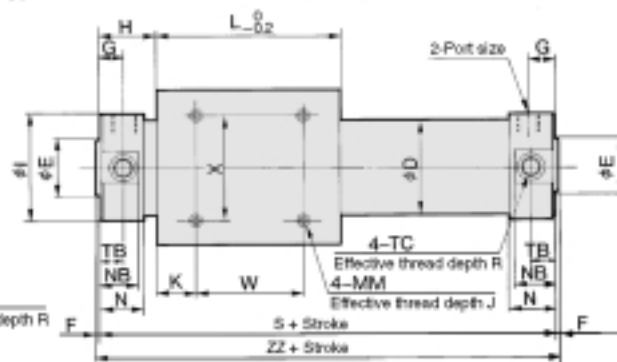

Model	Port size	B	C	D	E	F	G	H	I	K	L	MM x J	N	NA	NB	NN
CY1B20	Rc(PT)1/8	36	—	22.8	—	13	8	20	28	8	66	M4 x 0.7 x 6	15	24	13	M20 x 1.5
CY1B25	Rc(PT)1/8	46	—	27.8	—	13	8	20.5	34	10	70	M5 x 0.8 x 8	15	30	13	M26 x 1.5
CY1B32	Rc(PT)1/8	60	—	35	—	16	9	22	40	15	80	M6 x 1.0 x 8	17	36	15	M26 x 1.5
CY1B40	Rc(PT)1/4	70	—	43	—	16	11	29	50	16	92	M6 x 1.0 x 10	21	46	19	M32 x 2.0
CY1B50	Rc(PT)1/4	86	32	53	30 ^{-0.007/-0.037}	2	14	33	58.2	25	110	M8 x 1.25 x 12	25	55	23	—
CY1B63	Rc(PT)1/4	100	38	66	32 ^{-0.007/-0.043}	2	14	33	72.2	26	122	M8 x 1.25 x 12	25	69	23	—







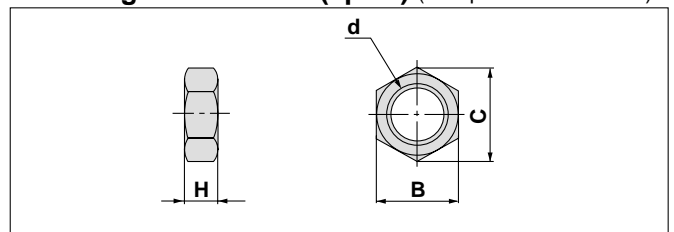

(mm)

Model	Q x R	S	TB	TC x R	W	X	ZZ
CY1B20	—	106	—	—	50	25	132
CY1B25	—	111	—	—	50	30	137
CY1B32	—	124	—	—	50	40	156
CY1B40	—	150	—	—	60	40	182
CY1B50	M8 x 1.25 x 16	176	14	M12 x 1.25 x 7.5	60	60	180
CY1B63	M10 x 1.5 x 16	188	14	M14 x 1.5 x 11.5	70	70	192

Mounting nut/included (2pcs.) (except for ø50 and ø63)



Part No.	Applicable bore size (mm)	d	H	B	C
SNJ-016B	6, 10, 15	M10 x 1.0	4	14	16.2
SN-020B	20	M20 x 1.5	8	26	30
SN-032B	25, 32	M26 x 1.5	8	32	37
SN-040B	40	M32 x 2.0	10	41	47.3

-  CY1B6 ----- SCY1B, #1
-  CY1B10 ----- SCY1B, #2
-  CY1B15 ----- SCY1B, #3
-  CY1B20 ----- SCY1B20, #1
-  CY1B25 ----- SCY1B, #4
-  CY1B32 ----- SCY1B, #5
-  CY1B40 ----- SCY1B, #6
-  CY1B50 ----- SCY1B, #7
-  CY1B63 ----- SCY1B, #8

⚠ Specific product Precautions

Be sure to read before handling. Refer to pages 72 through 75 for safety instructions and actuator precautions.

Mounting

⚠ Caution

1. Take care to avoid nicks or other damage on the outside surface of the cylinder tube.

This can lead to damage of the scraper and wear ring, which in turn can cause malfunction.

2. Take care regarding rotation of the external slider.

Rotation should be controlled by connecting it to another shaft (linear guide, etc.).

3. Do not operate with the magnetic coupling out of position.

In case the magnetic coupling is out of position, push the external slider back into the correct position by hand at the end of the stroke (or correct the piston slider with air pressure).

4. Be sure that both head covers are secured to a mounting surface before operating the cylinder.

Avoid operation with the external slider secured to the surface.

5. Do not apply a lateral load to the external slider.

When a load is mounted directly to the cylinder, variations in the alignment of each shaft center cannot be assimilated, and this results in the generation of a lateral load that can cause malfunction. The cylinder should be operated using a connection method which allows for assimilation of shaft alignment variations and deflection due to the cylinder's own weight. A drawing of a recommended mounting is shown in Figure 2.

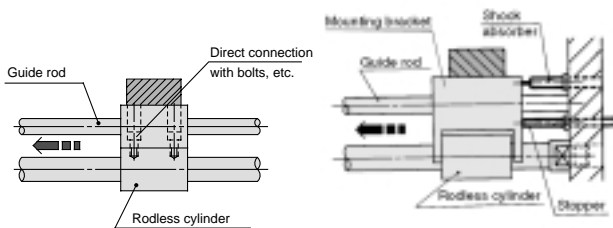

Variations in the load and cylinder shaft alignment cannot be assimilated, resulting in malfunction.

Shaft alignment variations are assimilated by providing clearance for the mounting bracket and cylinder. Moreover, the mounting bracket is extended above the cylinder shaft center, so that the cylinder is not subjected to moment.

Figure 1. Incorrect mounting Figure 2. Recommended mounting

6. Use caution regarding the allowable load weight when operating in a vertical direction.

The allowable load weight when operating in a vertical direction (reference values on page 5) is determined by the model selection method, however, if a load greater than the allowable value is applied, the magnetic coupling may break and there is a possibility of dropping the load. When using this type of application, contact SMC regarding the operating conditions (pressure, load, speed, stroke, frequency, etc.).

Disassembly & Maintenance

⚠ Warning

1. Use caution as the attractive power of the magnets is very strong.

When removing the external slider and piston slider from the cylinder tube for maintenance, etc., handle with caution, since the magnets installed in each slider have very strong attractive power.

⚠ Caution

1. When reattaching the head covers after disassembly, confirm that they are tightened securely.

When disassembling, hold the wrench flat section of one head cover with a vise, and remove the other cover using a spanner or adjustable angle wrench on its wrench flat section. When retightening, first coat with Locktight (No. 542 red), and retighten 3 to 5° past the original position prior to removal.

2. Use caution when taking off the external slider, as the piston slider will be directly attracted to it.

When removing the external slider or piston slider from the cylinder tube, first force the sliders out of their magnetically coupled positions and then remove them individually while there is no longer any holding force. If they are removed when still magnetically coupled, they will be directly attracted to one another and will not come apart.

3. Since the magnetic holding force can be changed (for example, from CY1B25L to CY1B25H), contact SMC if this is necessary.

4. Do not disassemble the magnetic components (piston slider, external slider).

This can cause a loss of holding force and malfunction.

5. When disassembling to replace the seals and wear ring, refer to the separate disassembly instructions.

6. Note the direction of the external slider and piston slider.

Since the external slider and piston slider are directional for $\varnothing 6$, $\varnothing 10$ and holding force type L, refer to the drawings below when performing disassembly or maintenance. Put the external slider and piston slider together, and insert the piston slider into the cylinder tube so that they will have the correct positional relationship as shown in Figure 3. If they align as shown in Figure 4, insert the piston slider after turning it around 180°. If the direction is not correct, it will be impossible to obtain the specified holding force.

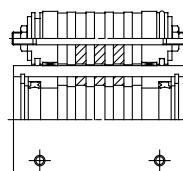

Figure 3. Correct position

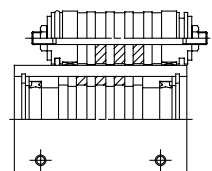

Figure 4. Incorrect position

Example for $\varnothing 20$ to $\varnothing 63$ with holding force type L

Series CY1R

Direct Mount Type



How to Order

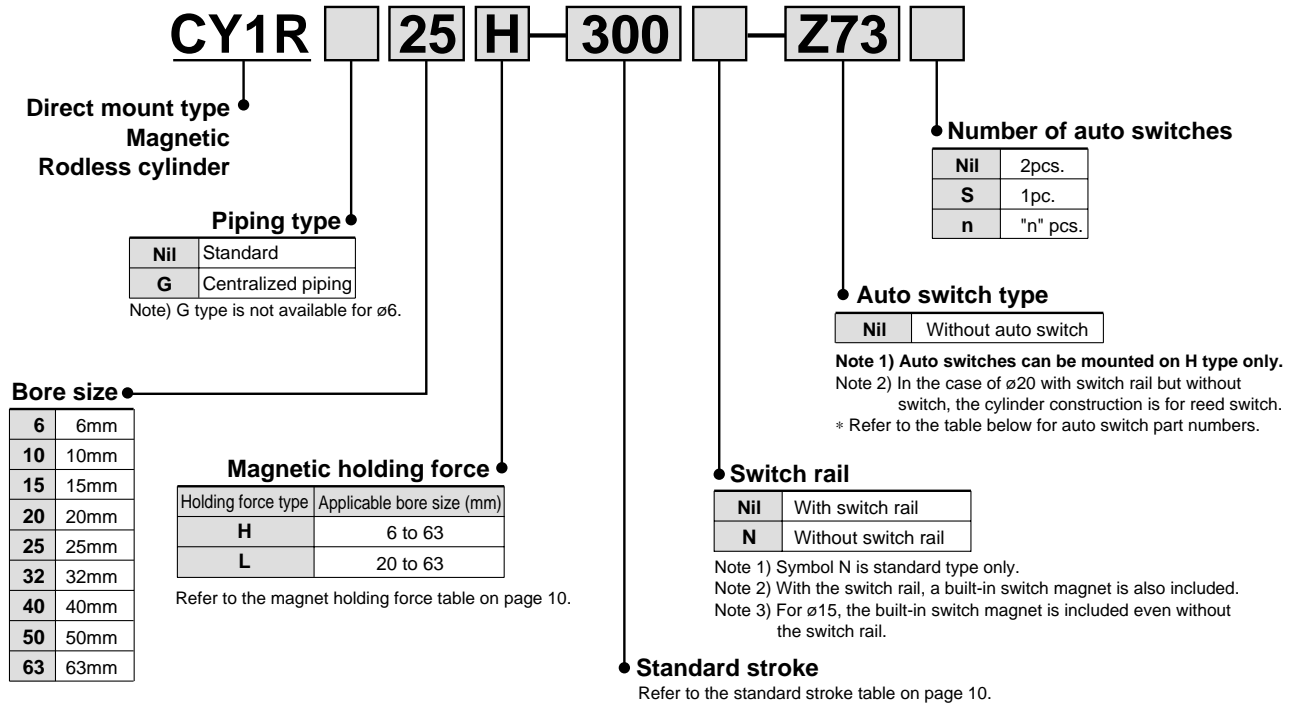

Applicable auto switch types for ø6, ø10, ø15, ø20

Refer to "Auto Switch Guide" (E274-A) for further details on auto switch units.
Refer to pages 60 and 61 for auto switch circuit diagrams.

Type	Special function	Electrical entry	Indicator light	Wiring (output)	Load voltage			Auto switch no.	Lead wire length (m) ^{Note 1)}			Applicable load	
					DC	AC			0.5 (Nil)	3 (L)	5 (Z)		
Reed switch	—	Grommet	No	2 wire	24V	5, 12V	100V or less	A90	●	●	—	IC circuit	Relay, PLC
			Yes			12V	100V	A93	●	●	—	—	
			—	3 wire (NPN equiv.)	—	5V	—	A96	●	●	—	IC circuit	—
Solid state switch	—	Grommet	Yes	3 wire (NPN)	24V	12V	—	F9N	●	●	—	—	Relay, PLC
				3 wire (PNP)				F9P	●	●	—		
				2 wire				F9B	●	●	—		

Note 1) Lead wire length symbol 0.5m Nil (Example) F9N
3m L F9NL

for ø25, ø32, ø40, ø50, ø63

Type	Special function	Electrical entry	Indicator light	Wiring (output)	Load voltage			Auto switch no.	Lead wire length (m) ^{Note 1)}			Applicable load	
					DC	AC			0.5 (Nil)	3 (L)	5 (Z)		
Reed switch	—	Grommet	Yes	3 wire	24V	5V	100V or less	Z76	●	●	—	IC circuit	—
			No	2 wire		12V		100V	Z73	●	●	●	
			—	3 wire (NPN equiv.)	5, 12V	—	Z80	●	●	—	IC circuit	Relay, PLC	
Solid state switch	Diagnostic indication (2 color indicator)	Grommet	Yes	3 wire (NPN)	24V	5, 12V	—	Y59A	●	●	○	IC circuit	Relay, PLC
				3 wire (PNP)				Y7P	●	●	○		
				2 wire				Y59B	●	●	○		
				3 wire (NPN)				Y7NW	●	●	○		
				3 wire (PNP)				Y7PW	●	●	○		
				2 wire				Y7BW	●	●	○		

Note 1) Lead wire length symbol 0.5m Nil (Example) FY59A
3m L Y59AL
5m Z Y59AZ

Note 2) Solid state auto switches marked with a "○" are produced upon receipt of order.

Series CY1R



Specifications

1MPa: Approx. 10.2kgf/cm²

Fluid	Air
Proof pressure	1.05MPa {10.7kgf/cm ² }
Max. operating pressure	0.7MPa {7.1kgf/cm ² }
Min. operating pressure	0.18MPa {1.8kgf/cm ² }
Ambient & fluid temperature	- 10 to 60°C
Piston speed ^{Note)}	50 to 500mm/s
Cushion	Rubber bumpers at both ends
Lubrication	Non-lube
Stroke length tolerance	0 to 250st: $+1.0_0$, 251 to 1000st: $+1.4_0$, 1001st & up: $+1.8_0$
Mounting method	Direct mount type

Note) When an auto switch is placed at an intermediate position, the maximum piston speed should be limited to no more than 300mm/s due to relays, etc.

Standard Stroke Table

Mounting bracket type
<ul style="list-style-type: none"> When mounting a floating bracket to a Series CY1R body, refer to page 68 for details, as this will be an order made product.

Bore size (mm)	Standard stroke (mm)	Max. available ^{Note)} stroke (mm)	Max. stroke with switch (mm)
6	50, 100, 150, 200	300	300
10	50, 100, 150, 200, 250, 300	500	500
15	50, 100, 150, 200, 250, 300 350, 400, 450, 500	1000	750
20	100, 150, 200, 250, 300, 350 400, 450, 500, 600, 700, 800	1500	1000
25		2000	1500
32			
40	100, 150, 200, 250, 300, 350 400, 450, 500, 600, 700, 800 900, 1000	2000	1500
50			
63			

Note) Contact SMC if the maximum stroke will be exceeded.

Magnetic Holding Force (N)

1N: Approx. 0.102kgf

Bore size (mm)		6	10	15	20	25	32	40	50	63
Holding force type	H type	19.6	53.9	137	231	363	588	922	1471	2256
	L type	—	—	—	154	221	358	569	863	1373

Theoretical Cylinder Thrust

⚠ Caution When calculating the actual thrust, design should consider the minimum actuating pressure.

ø6, ø10

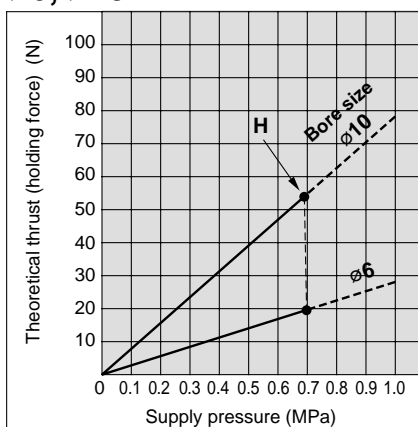

ø15, ø20, ø25, ø32, ø40

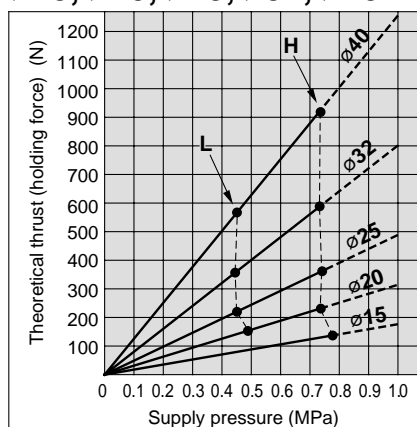

ø50, ø63

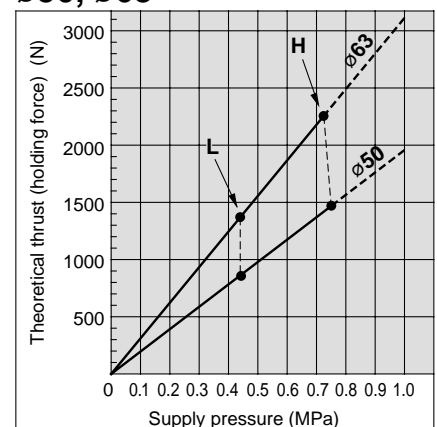

Weight Table

Unit: kg

Item		Bore size (mm)								
		6	10	15	20	25	32	40	50	63
Basic weight (for 0st)	CY1R□H CY1RG□H (with switch rail)	0.092	0.111	0.277	0.440	0.660	1.27	2.06	3.59	5.45
	CY1R□L CY1RG□L (with switch rail)	–	–	–	0.330	0.570	1.12	1.88	3.29	4.95
	CY1R□H (without switch rail)	0.075	0.080	0.230	0.370	0.580	1.15	1.90	3.30	5.10
	CY1R□L (without switch rail)	–	–	–	0.260	0.490	1.00	1.72	3.00	4.60
Additional weight per 50st (with switch rail)		0.016	0.034	0.045	0.071	0.083	0.113	0.133	0.177	0.212
Additional weight per 50st (without switch rail)		0.004	0.014	0.020	0.040	0.050	0.070	0.080	0.095	0.120

Calculation method/Example: CY1R25H-500 (with switch rail)
 Basic weight...0.660 (kg), Additional weight...0.083 (kg/50st), Cylinder stroke ...500 (st)
 $0.660 + 0.083 \times 500 = 1.49$ (kg)

Series CY1R Model Selection Method 1

E: Kinetic energy of load (J)

$$E = \frac{(W+W_b)}{2} \times \left(\frac{V}{1000}\right)^2$$

Es: Allowable kinetic energy for intermediate stop using an air pressure circuit (J)

Fn: Allowable driving force (N)

Md: Maximum allowable moment (N·m) when a connection fitting, etc. is carried directly

Ps: Operating pressure limit for intermediate stop using an external stopper, etc. (MPa)

Pv: Maximum operating pressure for vertical operation (MPa)

W_{Bmax}: Maximum load weight (kg) when loaded directly on the body

Operating conditions

- W: Load weight (kg)
- WB: Connection fitting weight (kg)
- μ: Guide's coefficient of friction
- Lo: Distance from cylinder shaft center to work piece point of application (cm)
- L1: Distance from cylinder shaft center to connection fitting, etc. center of gravity (mm)
- Switches
- P: Operating pressure (MPa)
- V: Speed (mm/s)
- Stroke (mm)
- Mode of operation (horizontal, inclined, vertical)

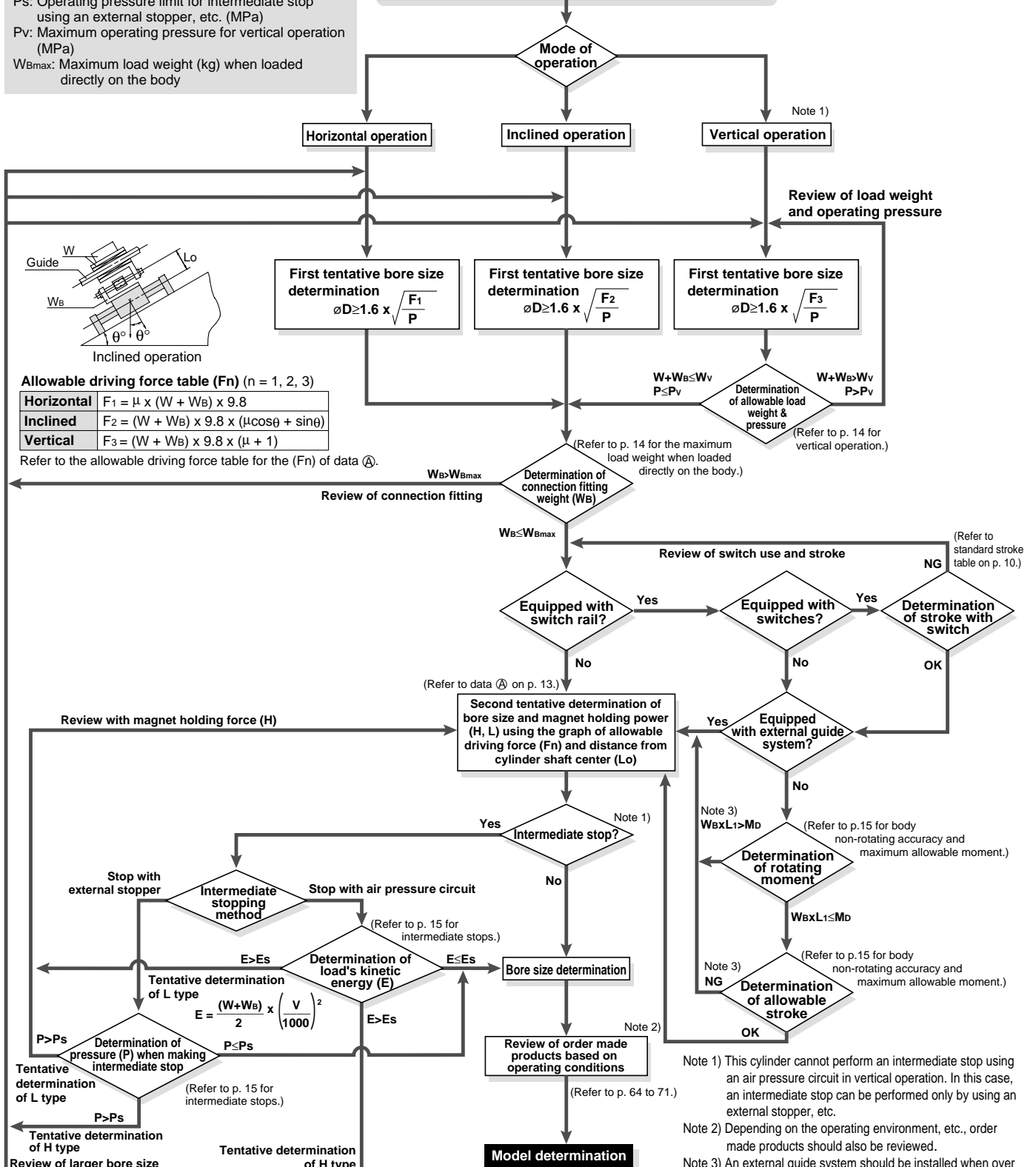

Series CY1R

Model Selection Method 2

Precautions on Design (1)

Selection procedure

1. Find the drive resisting force F_n (N) when moving the load horizontally.
2. Find the distance L_o (cm) from the point of the load where driving force is applied, to the center of the cylinder shaft.
3. Select the bore size and type of magnet holding force (types H, L) from L_o and F_n based on data (A).

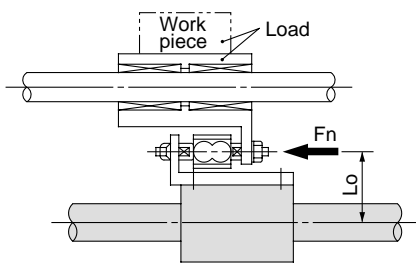

Selection example

Given a load drive resisting force of $F_n = 100$ (N) and a distance from the cylinder shaft center to the load application point of $L_o = 8$ cm, find the intersection point by extending upward from the horizontal axis of data (A) where the distance from the shaft center is 8 cm, and then extending to the side, find the allowable driving force on the vertical axis.

Models suitable to satisfy the requirement of 100 (N) are **CY1R32H** or **CY1R40H**, **CY1R40L**.

<Data (A): Distance from cylinder shaft center — Allowable driving capacity>

CY1R6

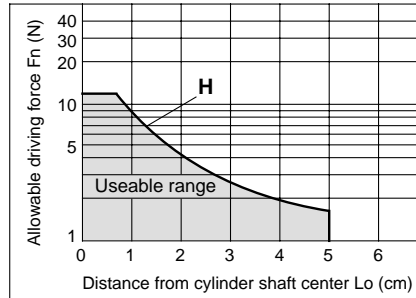

CY1R32

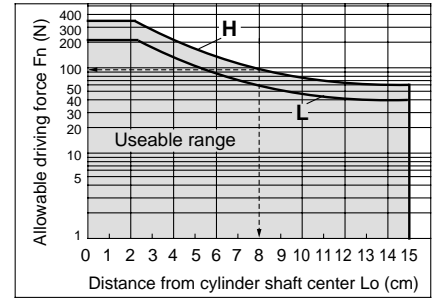

CY1R10

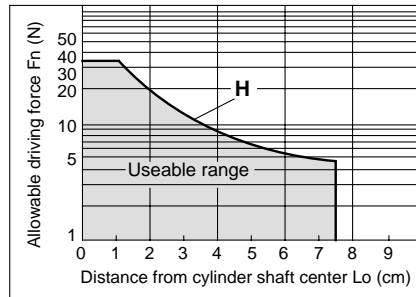

CY1R40

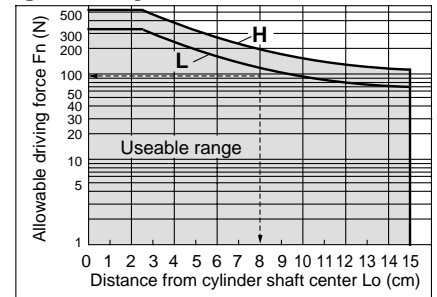

CY1R15

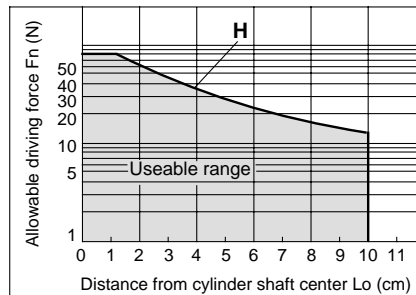

CY1R50

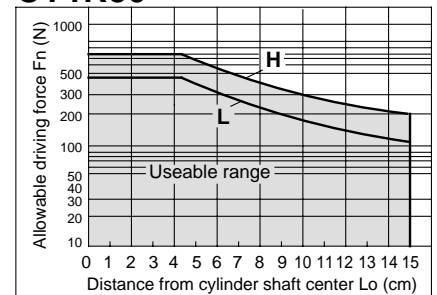

CY1R20

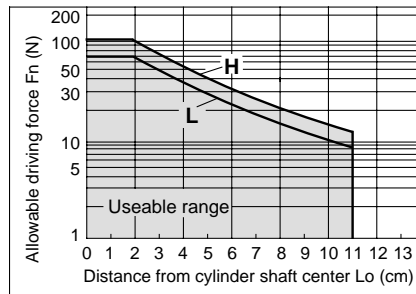

CY1R63

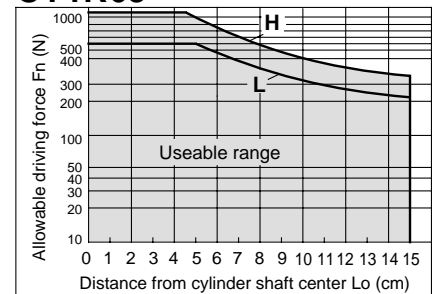

CY1R25

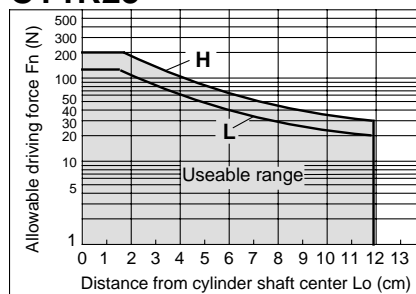

Series CY1R Model Selection Method 3

Precautions on Design (2)

Cylinder Dead Weight Deflection

When the cylinder is mounted horizontally, deflection appears due to its own weight as shown in the data, and the longer the stroke is, the greater the amount of variation in the shaft center. Therefore, a connection method should be considered which can assimilate this deflection.

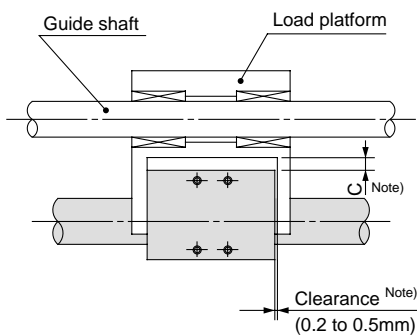

Note) Referring to the self weight deflection in the figure below, provide clearance so that the cylinder does not touch the mounting surface or the load, etc., and is able to operate smoothly within the minimum operating pressure range for a full stroke.

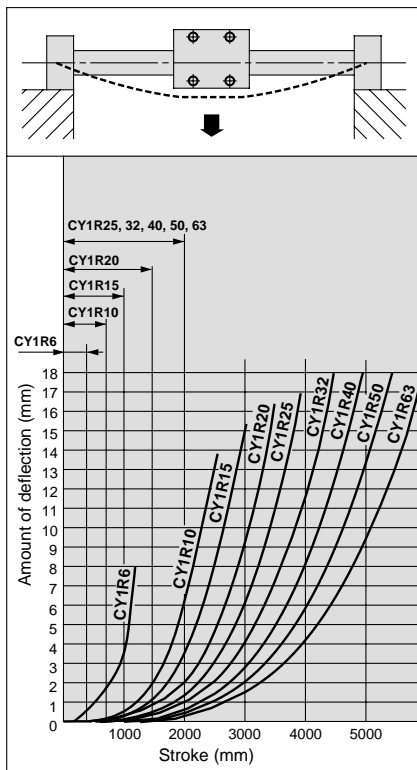

* The above deflection data indicate values when the external slider has moved to the middle of the stroke.

Vertical Operation

The load should be guided by a ball type bearing (LM guide, etc.). If a slide bearing is used, sliding resistance increases due to the load weight and load moment, which can cause malfunction.

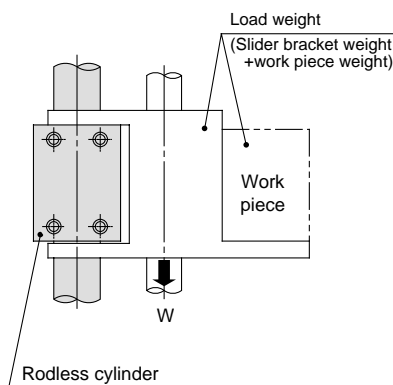

1MPa: Approx. 10.2kgf/cm²

Cylinder bore size (mm)	Model	Allowable load weight (Wv) (kg)	Max. operating pressure (Pv) (MPa)
6	CY1R 6H	1.0	0.55
10	CY1R10H	2.7	0.55
15	CY1R15H	7.0	0.65
20	CY1R20H	11.0	0.65
	CY1R20L	7.0	0.40
25	CY1R25H	18.5	0.65
	CY1R25L	11.2	0.40
32	CY1R32H	30.0	0.65
	CY1R32L	18.2	0.40
40	CY1R40H	47.0	0.65
	CY1R40L	29.0	0.40
50	CY1R50H	75.0	0.65
	CY1R50L	44.0	0.40
63	CY1R63H	115.0	0.65
	CY1R63L	70.0	0.40

Note) Use caution, as there is a danger of breaking the magnetic coupling if operated above the maximum operating pressure.

Max. Load Weight when Loaded Directly on Body

When the load is applied directly to the body, it should be no greater than the maximum values shown in the table below.

Model	Maximum load weight (W _{Bmax})(kg)
CY1R 6H	0.2
10H	0.4
15H	1.0
20□	1.1
25□	1.2
32□	1.5
40□	2.0
50□	2.5
63□	3.0

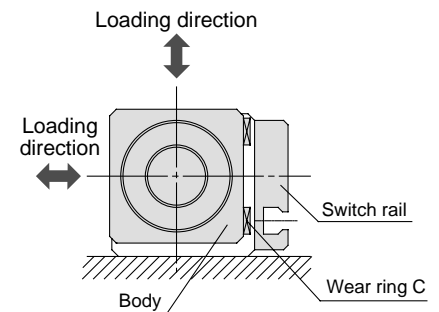

Series CY1R Model Selection Method 4

Precautions on Design (3)

Intermediate Stops

(1) Intermediate stopping of load with an external stopper, etc.

When stopping a load in mid-stroke using an external stopper, etc., operate within the operating pressure limits shown in the table below. Use caution, as operation at a pressure exceeding these limits can result in breaking of the magnetic coupling.

1MPa: Approx. 10.2kgf/cm²

Bore size (mm)	Model	Operating pressure limit for intermediate stop (Ps)(MPa)
6	CY1R 6H	0.55
10	CY1R10H	0.55
15	CY1R15H	0.65
20	CY1R20H	0.65
	CY1R20L	0.40
25	CY1R25H	0.65
	CY1R25L	0.40
32	CY1R32H	0.65
	CY1R32L	0.40
40	CY1R40H	0.65
	CY1R40L	0.40
50	CY1R50H	0.65
	CY1R50L	0.40
63	CY1R63H	0.65
	CY1R63L	0.40

(2) Intermediate stopping of load with an air pressure circuit

When performing an intermediate stop of a load using an air pressure circuit, operate at or below the kinetic energy shown in the table below. Use caution, as operation when exceeding the allowable value can result in breaking of the magnetic coupling.

(Reference values)

Bore size (mm)	Model	Allowable kinetic energy for intermediate stop (Es)(J)
6	CY1R 6H	0.007
10	CY1R10H	0.03
15	CY1R15H	0.13
20	CY1R20H	0.24
	CY1R20L	0.16
25	CY1R25H	0.45
	CY1R25L	0.27
32	CY1R32H	0.88
	CY1R32L	0.53
40	CY1R40H	1.53
	CY1R40L	0.95
50	CY1R50H	3.12
	CY1R50L	1.83
63	CY1R63H	5.07
	CY1R63L	3.09

Body Non-rotating Accuracy and Maximum Allowable Moment (with Switch Rail) (Reference Values)

Reference values for non-rotating accuracy and maximum allowable moment at stroke end are indicated below.

Bore size (mm)	Non-rotating accuracy (°)	Max. allowable moment (M ₀) (N·m)	Allowable stroke (mm) ^{Note 2)}
6	7.3	0.02	100
10	6.0	0.05	100
15	4.5	0.15	200
20	3.7	0.20	300
25	3.7	0.25	300
32	3.1	0.40	400
40	2.8	0.62	400
50	2.4	1.00	500
63	2.2	1.37	500

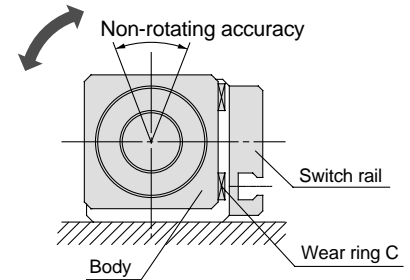

Note 1) Avoid operations where rotational torque (moment) is applied. In such a case, the use of an external guide is recommended.

Note 2) The above reference values will be satisfied within the allowable stroke ranges, but caution is necessary, because as the stroke becomes longer, the inclination (rotation angle) within the stroke can be expected to increase.

Note 3) When a load is applied directly to the body, the loaded weight should be no greater than the allowable load weights on page 14.

Stroke End Stopping Method

When stopping a load having a large inertial force at the stroke end, tilting of the body and damage to the bearings and cylinder tube may occur. (Refer to the left hand drawing below.)

As shown in the right hand drawing below, a shock absorber should be used together with the stopper, and thrust should also be transmitted from the center of the body so that tilting will not occur.

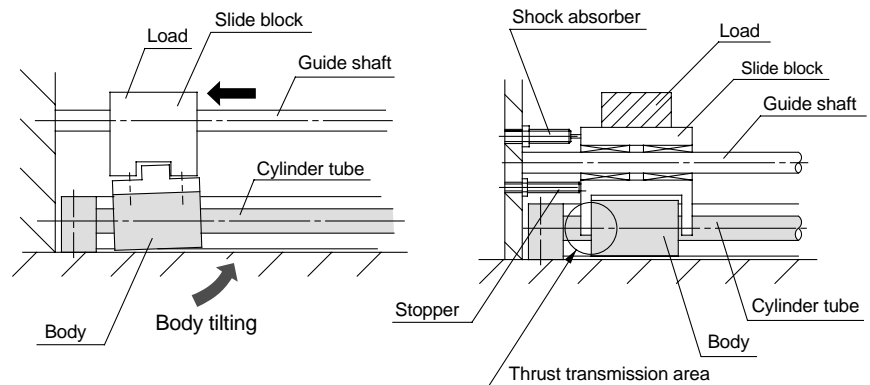

Series CY1R

Construction/Standard Type

CY1R6H

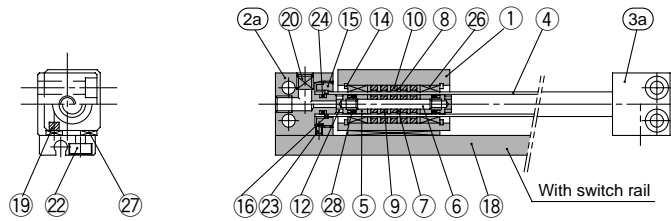

CY1R10H

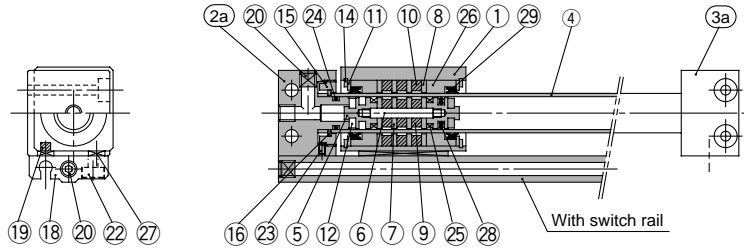

CY1R15H to 63H

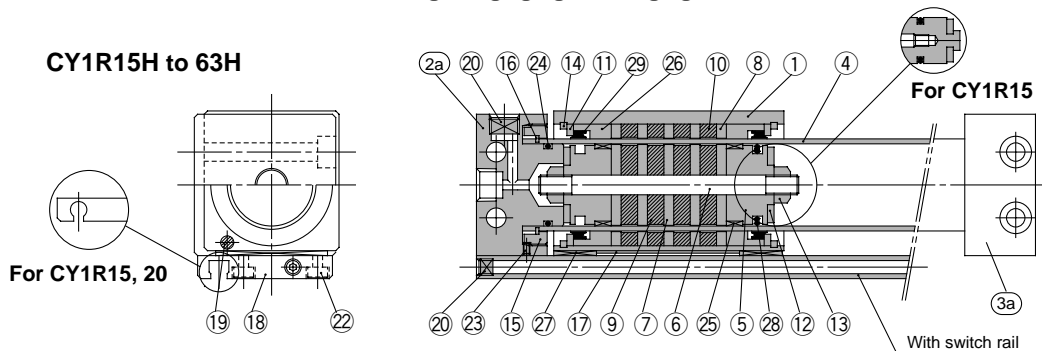

Parts list

No.	Description	Material	Note
1	Body	Aluminum alloy	Hard anodized
2a	End cover A	Aluminum alloy	Hard anodized
2b	End cover C	Aluminum alloy	Hard anodized
3a	End cover B	Aluminum alloy	Hard anodized
3b	End cover D	Aluminum alloy	Hard anodized
4	Cylinder tube	Stainless steel	
5	Piston	ø6 to ø15: Brass ø20 to ø63: Aluminum alloy	ø6 to ø15: Kanigen plated ø20 to ø63: Chromated
6	Shaft	Stainless steel	
7	Piston side yoke	Rolled steel plate	Zinc chromated
8	External slider side yoke	Rolled steel plate	Zinc chromated
9	Magnet A	Rare earth magnet	
10	Magnet B	Rare earth magnet	
11	Spacer	Rolled steel plate	Nickel plated
12	Bumper	Urethane rubber	
13	Piston nut	Carbon steel	ø 20 to ø63
14	Snap ring	Carbon tool steel	Nickel plated
15	Attachment ring	Aluminum alloy	Hard anodized
16	C type snap ring for shaft	ø10, ø25, ø32 Stainless steel ø6, ø15, ø20, ø40, ø50, ø63 Hard steel wire	
17	Magnetic shielding plate	Rolled steel plate	Chromated
18	Switch rail	Aluminum alloy	White anodized
19	Magnet	Rare earth magnet	
20	Hexagon socket head plug	Chrome steel	Nickel plated

No.	Description	Material	Note
21	Steel ball	Chrome steel	ø40: Hexagon socket head plug ø20, ø50, ø63 : None
22	Hexagon socket head screw	Chrome steel	Nickel plated
23	Hexagon socket head set screw	Chrome steel	Nickel plated
* 24	Cylinder tube gasket	NBR	
* 25	Wear ring A	Special resin	
* 26	Wear ring B	Special resin	
* 27	Wear ring C	Special resin	
* 28	Piston seal	NBR	
* 29	Scraper	NBR	
* 30	Switch rail gasket	NBR	

* Seal kits are sets consisting of items 24 through 30, and can be ordered using the order number for each bore size.

Replacement parts: Seal kits

Bore size (mm)	Order No.	Content
6	CY1R 6 -PS	Nos. 24, 26, 27, 28 above
10	CY1R10-PS	Nos. 24, 25, 26, 27, 28, 29, 30 above
15	CY1R15-PS	
20	CY1R20-PS	
25	CY1R25-PS	
32	CY1R32-PS	
40	CY1R40-PS	
50	CY1R50-PS	
63	CY1R63-PS	

Construction/Centralized Piping Type

Note) Centralized piping is not available for ø6.

CY1RG10H

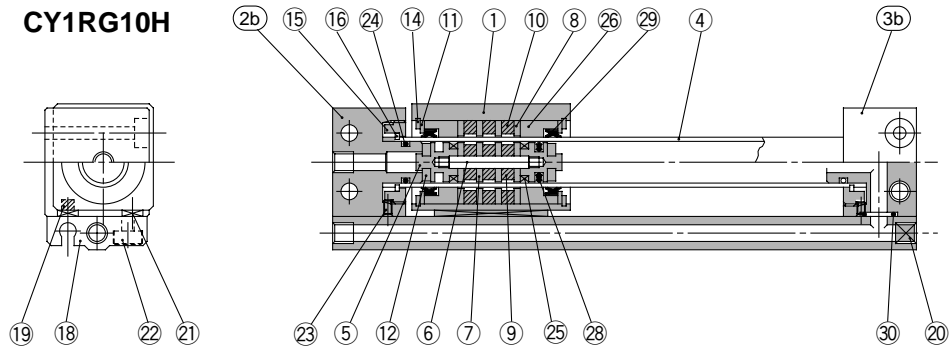

CY1RG15H

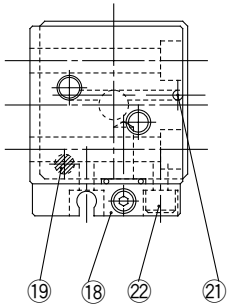

CY1RG20H to 63H

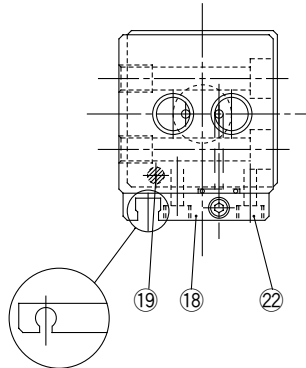

For CY1RG20

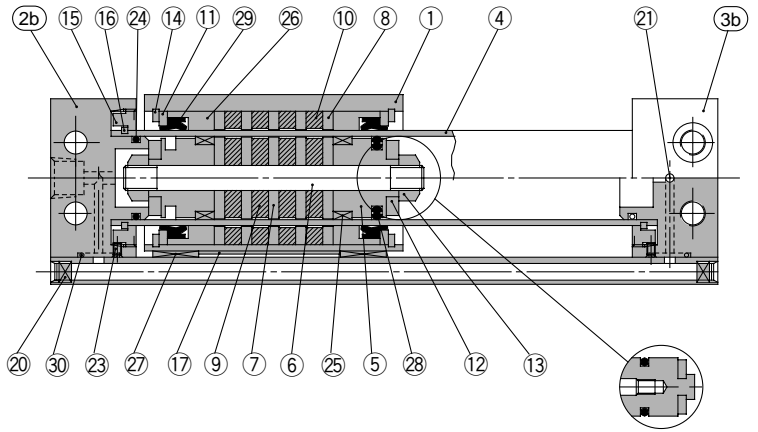

For CY1RG15

Replacement parts: Seal kits

Bore size (mm)	Order No.	Content
10	CY1R10-PS	Nos. 24, 25, 26, 27, 28, 29, 30 at the left
15	CY1R15-PS	
20	CY1R20-PS	
25	CY1R25-PS	
32	CY1R32-PS	
40	CY1R40-PS	
50	CY1R50-PS	
63	CY1R63-PS	

* Seal kits are the same for both the standard type and the centralized piping type.

Switch Rail Accessory Type

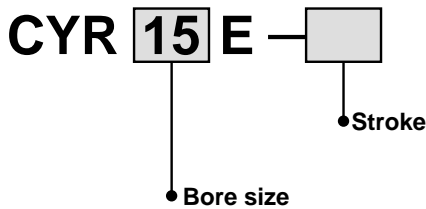

Switch rail accessory kits

Bore size (mm)	Order No.	Content
6	CYR 6E-□	Nos.18, 19, 22, 27 at the left
10	CYR10E-□	Nos.18, 19, 20, 22, 27 at the left
15	CYR15E-□	Nos.17, 18, 20, 22, 27 at the left ^{Note 2)}
20	Reed switch	CYR20E-□
	Solid state switch	CYR20EN-□
25	CYR25E-□	Nos. 17, 18, 19, 20, 22, 27 at the left
32	CYR32E-□	
40	CYR40E-□	
50	CYR50E-□	
63	CYR63E-□	

Note 1) □ indicates the stroke.

Note 2) A magnet is already built in for ø15.

Series CY1R

Standard Type: $\varnothing 6$ to $\varnothing 63$



CY1R **Bore size** $\frac{H}{L}$ - **Stroke** $\frac{Nil}{N}$

Note 1) Type L is not available for $\varnothing 6$ through $\varnothing 15$.
 Note 2) This drawing shows the version with switch rail (nil).

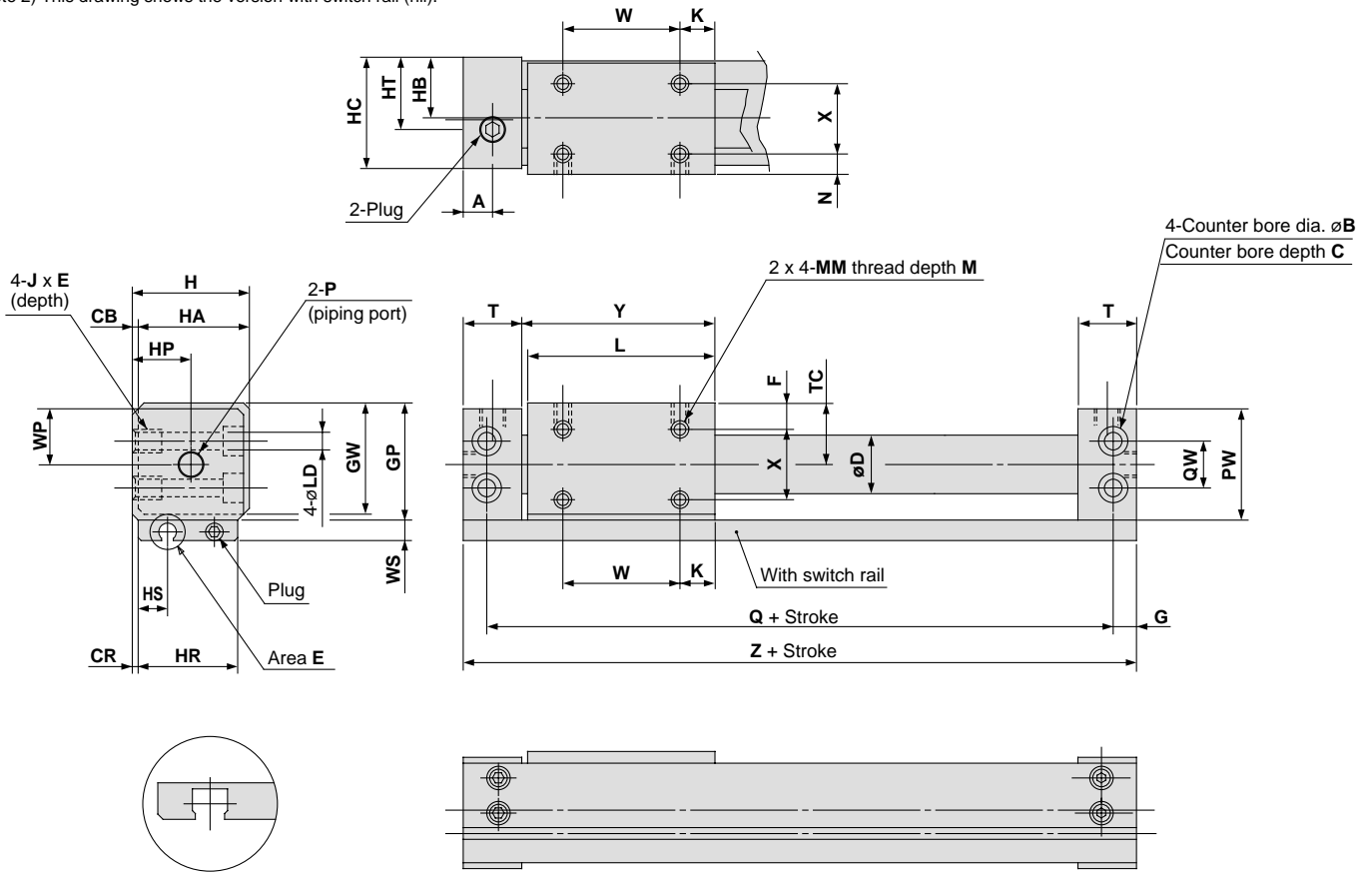

(Area E) For CY1R25, 32, 40, 50, 63

Model	A	B	C	CB	CR	D	F	G	GP	GW	H	HA	HB	HC	HP	HR	HS	HT	J x E
CY1R 6	9	6.5	3.2	2	0.5	7.6	5.5	4	20	18.5	19	17	10.5	18	9	17	6	7	M4 x 0.7 x 6
CY1R10	9	6.5	3.2	2	0.5	12	6.5	4	27	25.5	26	24	14	25	14	24	5	14	M4 x 0.7 x 6
CY1R15	10.5	8	4.2	2	0.5	17	8	5	33	31.5	32	30	17	31	17	30	8.5	17	M5 x 0.8 x 7
CY1R20	9	9.5	5.2	3	1	22.8	9	6	39	37.5	39	36	21	38	24	36	7.5	24	M6 x 1 x 8
CY1R25	8.5	9.5	5.2	3	1	27.8	8.5	6	44	42.5	44	41	23.5	43	23.5	41	6.5	23.5	M6 x 1 x 8
CY1R32	10.5	11	6.5	3	1.5	35	10.5	7	55	53.5	55	52	29	54	29	51	7	29	M8 x 1.25 x 10
CY1R40	10	11	6.5	5	2	43	13	7	65	63.5	67	62	36	66	36	62	8	36	M8 x 1.25 x 10
CY1R50	14	14	8.2	5	2	53	17	8.5	83	81.5	85	80	45	84	45	80	9	45	M10 x 1.5 x 15
CY1R63	15	14	8.2	5	3	66	18	8.5	95	93.5	97	92	51	96	51	90	9.5	51	M10 x 1.5 x 15

Model	K	L	LD	M	MM	N	P	PW	Q	QW	T	TC	W	WP	WS	X	Y	Z
CY1R 6	7	34	3.5	3.5	M3 x 0.5	3.5	M5 x 0.8	19	64	10	17.5	10.5	20	9.5	6	10	35.5	72
CY1R10	9	38	3.5	4	M3 x 0.5	4.5	M5 x 0.8	26	68	14	17.5	14	20	13	8	15	39.5	76
CY1R15	14	53	4.3	5	M4 x 0.7	6	M5 x 0.8	32	84	18	19	17	25	16	7	18	54.5	94
CY1R20	11	62	5.6	5	M4 x 0.7	7	Rc(PT) 1/8	38	95	17	20.5	20	40	19	7	22	64	107
CY1R25	15	70	5.6	6	M5 x 0.8	6.5	Rc(PT) 1/8	43	105	20	21.5	22.5	40	21.5	7	28	72	117
CY1R32	13	76	7	7	M6 x 1	8.5	Rc(PT) 1/8	54	116	26	24	28	50	27	7	35	79	130
CY1R40	15	90	7	8	M6 x 1	11	Rc(PT) 1/4	64	134	34	26	33	60	32	7	40	93	148
CY1R50	25	110	8.6	10	M8 x 1.25	15	Rc(PT) 1/4	82	159	48	30	42	60	41	10	50	113	176
CY1R63	24	118	8.6	10	M8 x 1.25	16	Rc(PT) 1/4	94	171	60	32	48	70	47	10	60	121	188

With auto switch
 CY1R6H SCY1R6, #1 (#1 + #2)
 For $\varnothing 10$ to $\varnothing 63$
 CY1R **Bore size** SCY1R **Bore size**, #1 (#1 + #3)

Series CY1R

Auto Switches/Proper Mounting Position for Stroke End Detection

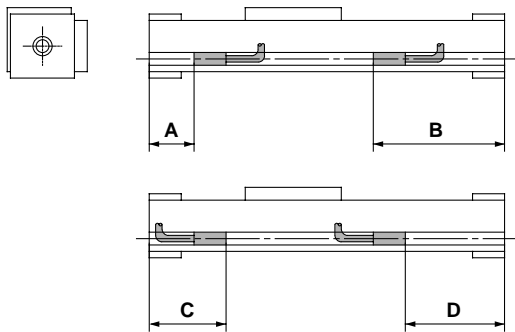

ø6 to ø20

Auto switch model Bore size (mm)	A		B		C		D	
	D-A9□	D-F9□	D-A9□	D-F9□	D-A9□	D-F9□	D-A9□	D-F9□
6	26	30	46	42	46	42	26	30
10	28	32	48	44	48	44	28	32
15	17.5	21.5	76.5	72.5	—	—	56.5	60.5
20	19.5	23.5	87.5	83.5	39.5	35.5	67.5	71.5

Note) Auto switches cannot be installed in Area C in the case of ø15.

ø25 to ø63

Auto switch model Bore size (mm)	A		B		C		D	
	D-Z7□ D-Z8□	D-Y5□ D-Y7□ D-Y7□W	D-Z7□ D-Z8□	D-Y5□ D-Y7□ D-Y7□W	D-Z7□ D-Z8□	D-Y5□ D-Y7□ D-Y7□W	D-Z7□ D-Z8□	D-Y5□ D-Y7□ D-Y7□W
25	18	18	97	99	43	43	74	74
32	21.5	21.5	108.5	108.5	46.5	46.5	83.5	83.5
40	23.5	23.5	124.5	124.5	48.5	48.5	99.5	99.5
50	27.5	27.5	148.5	148.5	52.5	52.5	123.5	123.5
63	29.5	29.5	158.5	158.5	54.5	54.5	133.5	133.5

Note) 50mm is the minimum stroke available with 2 auto switches mounted.

Auto Switch Mounting

1N·m: Approx. 10.2kgf·cm

When mounting auto switches, they should be inserted into the cylinder's switch groove from the direction shown in the drawing on the right. After setting in the mounting position, use a flat head watchmakers screw driver to tighten the mounting screw which is included.

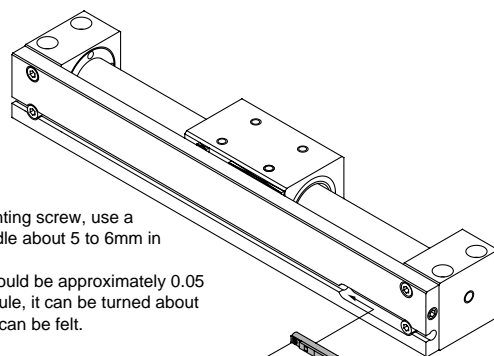

Note) When tightening the auto switch mounting screw, use a watchmakers screw driver with a handle about 5 to 6mm in diameter. Furthermore, the tightening torque should be approximately 0.05 to 0.1N·m (0.51 to 1.02kgf·cm). As a rule, it can be turned about 90° past the point at which tightening can be felt.

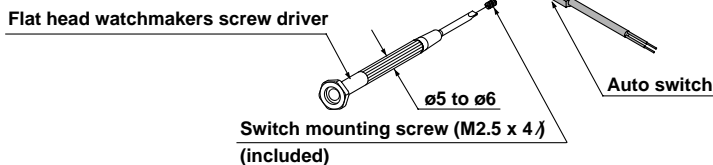

Auto Switch Specifications

- (1) Switches (switch rail) can be added to the standard type (without switch rail). The switch rail accessory type is mentioned on page 17, and can be ordered together with auto switches.
- (2) Refer to the separate disassembly instructions for switch magnet installation procedures.

Auto Switch Operation Range

Auto switch model Bore size (mm)	D-A9□	D-F9□	D-Z7□ D-Z8□	D-Y5□ D-Y7□ D-Y7□W
	6	9	5	—
10	13	7	—	—
15	8	5	—	—
20	6	4	—	—
25	—	—	9	7
32	—	—	9	6
40	—	—	11	6
50	—	—	11	7
63	—	—	11	6

Note 1) Switches cannot be mounted in some cases.
Note 2) Operating ranges are standards including hysteresis, and are not guaranteed. Large variations may occur depending on the surrounding environment (variation on the order of ±30%).

⚠ Specific product Precautions

Be sure to read before handling. Refer to pages 72 through 75 for safety instructions and actuator precautions.

Mounting

⚠ Caution

1. Take care to avoid nicks or other damage on the outside surface of the cylinder tube.

This can lead to damage of the scraper and wear ring, which in turn can cause malfunction.

2. Take care regarding rotation of the external slider.

Rotation should be controlled by connecting it to another shaft (linear guide, etc.).

3. Do not operate with the magnetic coupling out of position.

In case the magnetic coupling is out of position, push the external slider back into the correct position by hand at the end of the stroke (or correct the piston slider with air pressure).

4. The cylinder is mounted with bolts through the mounting holes in the end covers. Be sure they are tightened securely.

5. If gaps occur between the mounting surface and the end covers when mounting with bolts, perform shim adjustment using spacers, etc. so that there is no unreasonable stress.

6. Be sure that both end covers are secured to the mounting surface before operating the cylinder.

Avoid operation with the external slider secured to the surface.

7. Do not apply a lateral load to the external slider.

When a load is mounted directly to the cylinder, variations in the alignment of each shaft center cannot be assimilated, which results in the generation of a lateral load that can cause malfunction. The cylinder should be operated using a connection method which allows for assimilation of shaft alignment variations and deflection due to the cylinder's own weight. A drawing of a recommended mounting is shown in Figure 2.

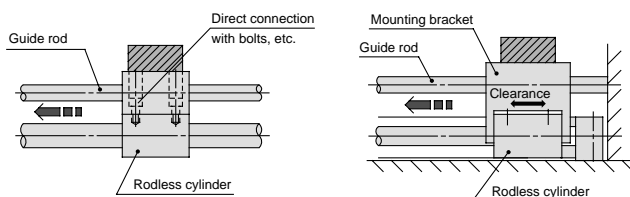

Figure 1. Incorrect mounting
Variations in the load and cylinder shaft alignment cannot be assimilated, resulting in malfunction.

Figure 2. Recommended mounting
Shaft alignment variations are assimilated by providing clearance for the mounting bracket and cylinder. Moreover, the mounting bracket is extended above the cylinder shaft center, so that the cylinder is not subjected to moment.

Figure 1. Incorrect mounting Figure 2. Recommended mounting

8. Use caution regarding the allowable load weight when operating in a vertical direction.

The allowable load weight when operating in a vertical direction (reference values on page 14) is determined by the model selection method, however, if a load greater than the allowable value is applied, the magnetic coupling may break and there is a possibility of dropping the load. When using this type of application, contact SMC regarding the operating conditions (pressure, load, speed, stroke, frequency, etc.).

Disassembly & Maintenance

⚠ Warning

1. Use caution as the attractive power of the magnets is very strong.

When removing the external slider and piston slider from the cylinder tube for maintenance, etc., handle with caution, since the magnets installed in each slider have very strong attractive power.

⚠ Caution

1. Special tools are necessary for disassembly.

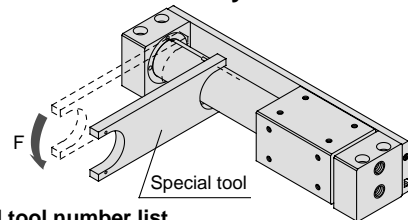

Special tool number list

No.	Applicable bore size (mm)
CYRZ-V	6, 10, 15, 20
CYRZ-W	25, 32, 40
CYRZ-X	50
CYRZ-Y	63

2. Use caution when taking off the external slider, as the piston slider will be directly attracted to it.

When removing the external slider or piston slider from the cylinder tube, first force the sliders out of their magnetically coupled positions and then remove them individually when there is no longer any holding force. If they are removed when still magnetically coupled, they will be directly attracted to one another and will not come apart.

3. Since the magnetic holding force can be changed (for example, from CY1R25L to CY1R25H), contact SMC if this is necessary.

4. Do not disassemble the magnetic components (piston slider, external slider).

This can cause a loss of holding force and malfunction.

5. When disassembling to replace the seals and wear ring, refer to the separate disassembly instructions.

6. Note the direction of the external slider and piston slider.

Since the external slider and piston slider are directional for $\phi 6$, $\phi 10$ and holding force type L, refer to the drawings below when performing disassembly or maintenance. Put the external slider and piston slider together, and insert the piston slider into the cylinder tube so that they will have the correct positional relationship as shown in Figure 3. If they align as shown in Figure 4, insert the piston slider after turning it around 180° . If the direction is not correct, it will be impossible to obtain the specified holding force.



Figure 3. Correct position Figure 4. Incorrect position

Example for $\phi 20$ to $\phi 63$ with holding force type L

Series CY1S

Slider Type/Slide Bearing



How to Order

Slide bearing CY1S 25 H 300

With auto switch CDY1S 25 H 300 A72

With switch rail

Slider type (slide bearing)

Bore size

6	6mm	25	25mm
10	10mm	32	32mm
15	15mm	40	40mm
20	20mm		

Magnetic holding force
Refer to the magnet holding force table on page 23.

Standard stroke
Refer to the standard stroke table on page 23.

Number of auto switches

Nil	2pcs.
S	1pc.
n	"n" pcs.

Auto switch type

Nil	Without auto switch
-----	---------------------

* Refer to the table below for applicable auto switch types.

Adjustment type

Nil	With adjustment bolt
B	With shock absorber (2pcs.)
BS	With shock absorber (with plate $\text{\textcircled{A}}$) * Installed on Side A at time of shipment.

Applicable auto switch types / Refer to "Auto Switch Guide" (E274-A) for further details on auto switch units. Refer to pages 60 and 61 for auto switch circuit diagrams.

Type	Special function	Electrical entry	Indicator light	Wiring (output)	Load voltage		Auto switch no.		Lead wire length (m) ^(Note 1)				Applicable load		
					DC	AC	Electrical entry direction	Lateral	0.5 (Nil)	3 (L)	5 (Z)	None (N)			
Reed switch	-	Grommet	Yes	3 wire (NPN equiv.)	-	5V	-	-	A76H	●	●	-	-	IC circuit	-
					-	-	200V	A72	A72H	●	●	-	-	-	-
		Connector	No	2 wire	24V	5V, 12V	100V or less	A80	A80H	●	●	-	-	IC circuit	Relay PLC
					24V	12V	-	A73C	-	●	●	●	●	-	
		No		5V, 12V	24V or less	A80C	-	●	●	●	●	●	●	IC circuit	
Solid state switch	-	Grommet	Yes	3 wire (NPN)	5V, 12V	-	-	F7NV	F79	●	●	○	-	IC circuit	Relay PLC
				3 wire (PNP)	12V			F7PV	F7P	●	●	○	-	-	
		Connector	No	2 wire	12V			F7BV	J79	●	●	○	-	-	
					24V			J79C	-	●	●	●	●	-	
	Diagnostic indication (2 color indicator)	Grommet	Yes	3 wire (NPN)	5V, 12V	F7NWV	F79W	●	●	○	-	IC circuit			
				3 wire (PNP)	12V	-	F7PW	●	●	○	-	-			
				2 wire	5V, 12V	F7BWV	J79W	●	●	○	-	-			
				Water resistant (2 color indicator)	12V	-	F7BA	-	●	○	-	-			
						5V, 12V	-	F7NT	-	●	○	-	IC circuit		
				With timer	5V, 12V	-	F79F	●	●	○	-	-			
With diagnostic output (2 color indicator)	-	-	F7LF	●	●	○	-	-							
Latch type with diagnostic output (2 color indicator)	4 wire (NPN)	-	-	-	-	-	-	-	-	-					

Note 1) Lead wire length symbol 0.5m Nil (Example) A 80C
3m L (Example) A80CL
5m Z (Example) A80CZ
None N (Example) A80CN

Note 2) Solid state auto switches marked with a "○" are produced upon receipt of order.

Note 3) Type D-F7LF cannot be mounted on bore sizes $\phi 6$ and $\phi 10$.



Load can be directly mounted
Strokes available up to 1500mm
Long life with no external leakage
With auto switches and shock absorbers

Models

Type	Bearing type	Model	Bore size (mm)	Auto switch model	Adjustable type
Slider type	Slide bearing	CY1S	6, 10, 15, 20, 25, 32, 40	D-A7, A8 D-F7, J7	With adjustment bolt With shock absorber

Specifications

1MPa: Approx.10.2kgf/cm²

Fluid	Air
Proof pressure	1.05MPa {10.7kgf/cm ² }
Max. operating pressure	0.7MPa {7.1kgf/cm ² }
Min. operating pressure	0.18MPa {1.8kgf/cm ² }
Ambient & fluid temperature	-10 to 60°C
* Piston speed	50 to 400mm/s
Cushion	Rubber bumpers at both ends
Lubrication	Non-lube
Stroke length tolerance	0 to 250st: ${}^{+1.0}_0$, 251 to 1000st: ${}^{+1.4}_0$, 1001st to: ${}^{+1.8}_0$
Mounting orientation	Unrestricted

* In the case of a model with auto switch (CDY1S) where an auto switch is mounted at an intermediate position, the maximum detectable piston speed is controlled by the response time of the load (relays, sequence controller, etc.).

Standard Stroke Table

Bore size (mm)	Standard stroke (mm)	Maximum available stroke (mm)
6	50, 100, 150, 200	300
10	50, 100, 150, 200, 250, 300	500
15	50, 100, 150, 200, 250, 300, 350 400, 450, 500	750
20	100, 150, 200, 250, 300, 350 400, 450, 500, 600, 700, 800	1000
25		1500
32		1500
40	100, 150, 200, 250, 300, 350 400, 450, 500, 600, 700, 800 900, 1000	1500

Principle Materials

Description	Material	Note
Plate A, B	Aluminum alloy	Hard anodized
Cylinder tube	Stainless steel	-
Guide shaft A, B	Carbon steel	Hard chrome plated
Magnet	Rare earth magnet	-
Slide block	Aluminum alloy	Hard anodized

Magnetic Holding Force (N)

1N: Approx. 0.102kgf

Bore size (mm)	6	10	15	20	25	32	40	
Holding force type	H type	19.6	53.9	137	231	363	588	922
	L type	-	-	81.4	154	221	358	569

Amount of Adjustment for Adjustment Bolt and Shock Absorber

Bore size (mm)	Adjustment bolt amount of adjustment (both sides) (mm)	Shock absorber amount of adjustment (mm)	
		Plate A side	Plate B side
6	12	17	11
10	11	14	6
15	7	14	4
20	11	36	27
25	10	12	3
32	11	33	23
40	9	32	17

* Since the cylinder is in an intermediate stop condition when stroke adjustment is performed, use caution regarding the operating pressure and the kinetic energy of the load.

Weight Table

(kg)

		Bore size (mm)		6	10	15	20	25	32	40
		Number of magnets	6	10	15	20	25	32	40	
Basic	CY1S□H	0.27	0.48	0.91	1.48	1.84	3.63	4.02		
	CY1S□L	-	-	0.85	1.37	1.75	3.48	3.84		
Additional weight per 50mm of stroke		0.044	0.074	0.104	0.138	0.172	0.267	0.406		

Calculation method/Example: CY1S32H-500

Basic weight ... 3.63kg Additional weight 0.267/50st Cylinder stroke 500
3.63 + 0.267 x 500 ÷ 50 = 6.3kg

With shock absorber

Refer to page 30 for details regarding Series CY1S with shock absorber.

Series CY1S Model Selection Method 1

E: Kinetic energy of load (J)

$$E = \frac{W}{2} \times \left(\frac{V}{1000} \right)^2$$

Es: Allowable kinetic energy for intermediate stop using an air pressure circuit (J)

Ps: Operating pressure limit for intermediate stop using an external stopper, etc. (MPa)

Pv: Maximum operating pressure for vertical operation (MPa)

WA: Allowable load weight based on these operating conditions (kg)

Wv: Allowable load weight for vertical operation (kg)

σ: Stroke coefficient

$$\sigma = \frac{\text{Load weight within stroke}}{\text{Maximum load weight}}$$

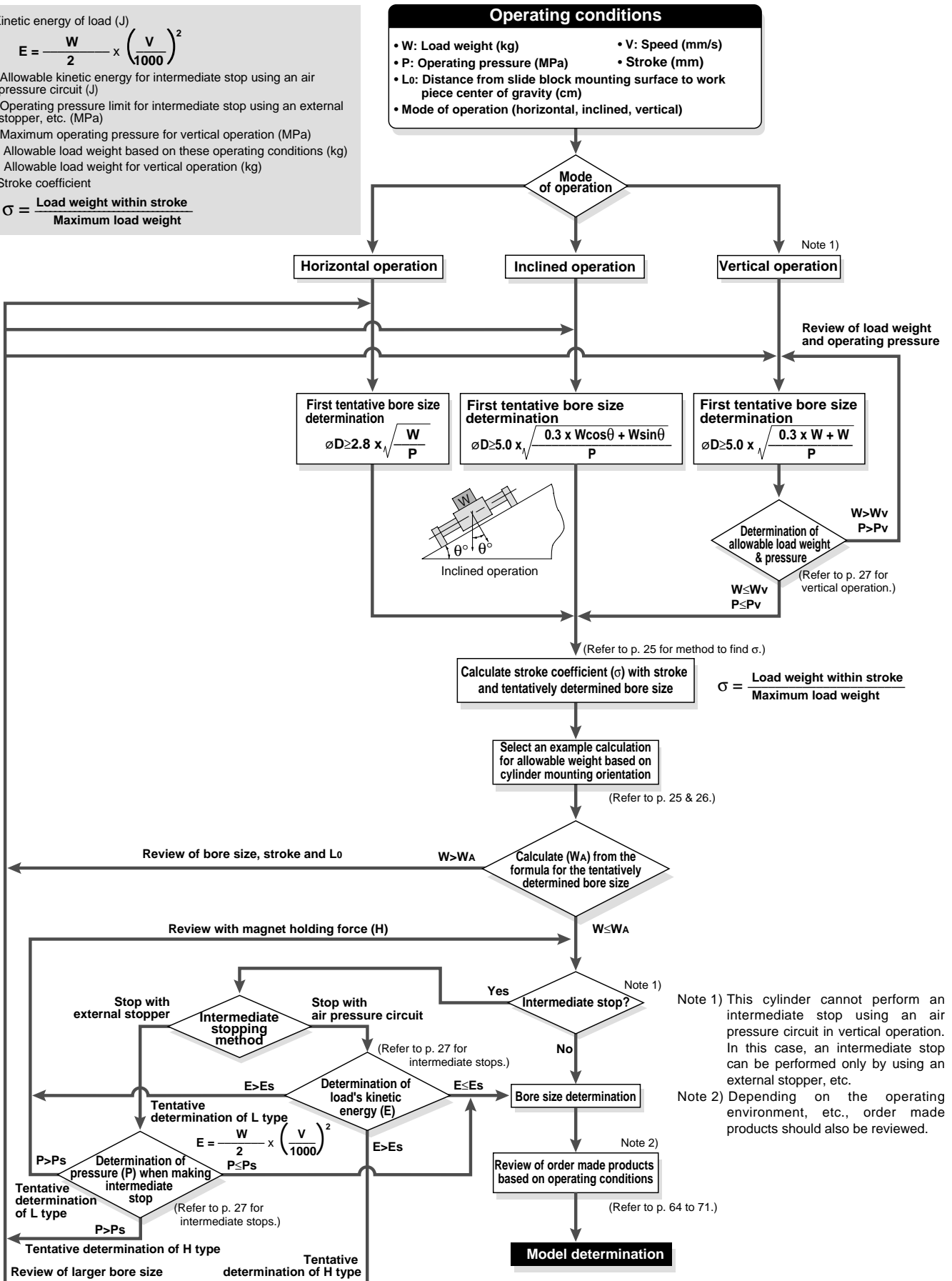

Series CY1S

Model Selection Method 2

Precautions on Design (1)

How to Find σ when Selecting the Allowable Load Weight

Since the maximum load weight with respect to the cylinder stroke changes as shown in the table below, σ should be considered as a coefficient determined in accordance with each stroke.

Example) for CY1S25 □-650

- (1) Maximum load weight = 20kg
- (2) Load weight for 650st = 13.6kg
- (3) $\sigma = \frac{13.6}{20} = 0.68$ is the result.

Calculation formula for σ ($\sigma \leq 1$)

ST: Stroke (mm)

Model	CY1S6	CY1S10	CY1S15
$\sigma =$	1	$\frac{10^{(0.86-1.3 \times 10^{-3} \times \text{ST})}}{3}$	$\frac{10^{(1.5-1.3 \times 10^{-3} \times \text{ST})}}{7}$
Model	CY1S20	CY1S25	CY1S32
$\sigma =$	$\frac{10^{(1.71-1.3 \times 10^{-3} \times \text{ST})}}{12}$	$\frac{10^{(1.98-1.3 \times 10^{-3} \times \text{ST})}}{20}$	$\frac{10^{(2.26-1.3 \times 10^{-3} \times \text{ST})}}{30}$
Model	CY1S40		
$\sigma =$	$\frac{10^{(2.48-1.3 \times 10^{-3} \times \text{ST})}}{50}$		

Note) Calculate with $\sigma=1$ for all applications up to $\phi 10-300\text{mmST}$, $\phi 15-500\text{mmST}$, $\phi 20-500\text{mmST}$, $\phi 25-500\text{mmST}$, $\phi 32-600\text{mmST}$ and $\phi 40-600\text{mmST}$.

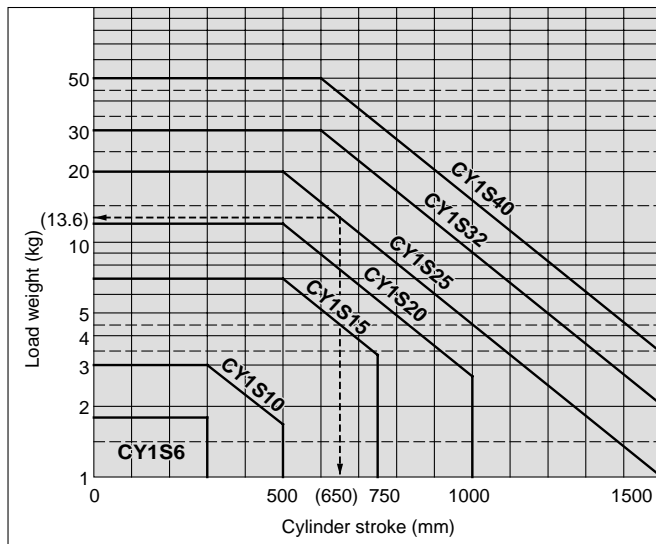

Examples of Allowable Load Weight Calculation Based on Cylinder Mounting Orientation

1. Horizontal operation (floor mounting)

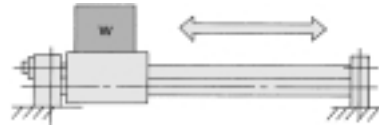

Bore size (mm)	6	10	15	20	25	32	40
Max. load weight (kg)	1.8	3	7	12	20	30	50
Stroke (max)	to 300st	to 300st	to 500st	to 500st	to 500st	to 600st	to 600st

The above maximum load weight values will change with the stroke length for each cylinder size, due to limitation from warping of the guide shafts. (Take note of the coefficient σ .) Moreover, depending on the operating direction, the allowable load weight may be different from the maximum load weight.

2. Horizontal operation (wall mounting)

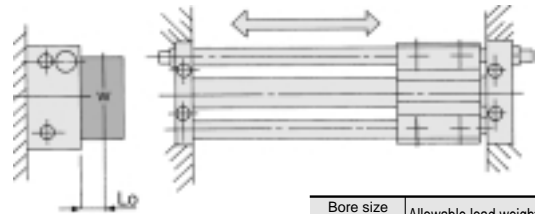

Lo: Distance from mounting surface to load center of gravity (cm)

Bore size (mm)	Allowable load weight (WA)(kg)
6	$\frac{\sigma \cdot 5.44}{7+2Lo}$
10	$\frac{\sigma \cdot 12.0}{8.4+2Lo}$
15	$\frac{\sigma \cdot 36.4}{10.6+2Lo}$
20	$\frac{\sigma \cdot 74.4}{12+2Lo}$
25	$\frac{\sigma \cdot 140}{13.8+2Lo}$
32	$\frac{\sigma \cdot 258}{17+2Lo}$
40	$\frac{\sigma \cdot 520}{20.6+2Lo}$

3. Vertical operation

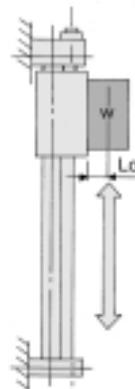

Bore size (mm)	Allowable load weight (WA)(kg)
6	$\frac{\sigma \cdot 1.33}{1.9+Lo}$
10	$\frac{\sigma \cdot 4.16}{2.2+Lo}$
15	$\frac{\sigma \cdot 13.23}{2.7+Lo}$
20	$\frac{\sigma \cdot 26.8}{2.9+Lo}$
25	$\frac{\sigma \cdot 44.0}{3.4+Lo}$
32	$\frac{\sigma \cdot 88.2}{4.2+Lo}$
40	$\frac{\sigma \cdot 167.8}{5.1+Lo}$

Lo: Distance from mounting surface to load center of gravity (cm)
 Note) A safety factor should be considered to prevent dropping.

Series CY1S Model Selection Method 3

Precautions on Design (2)

Examples of Allowable Load Weight Calculation Based on Cylinder Mounting Orientation

4. Inclined operation (in direction of operation)

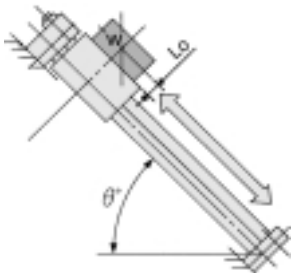

Angle	to 45°	to 60°	to 75°	to 90°
k	1	0.9	0.8	0.7

Angle coefficient (k) $k = [\text{to } 45^\circ (= \theta)] = 1$,
 $[\text{to } 60^\circ] = 0.9$,
 $[\text{to } 75^\circ] = 0.8$,
 $[\text{to } 90^\circ] = 0.7$

Lo: Distance from mounting surface to load center of gravity (cm)

Bore size (mm)	Allowable load weight (WA)(kg)
6	$\sigma \cdot 5.1 \cdot K$
	$3\cos \theta + 2(1.9+Lo)\sin \theta$
10	$\sigma \cdot 10.5 \cdot K$
	$3.5\cos \theta + 2(2.2+Lo)\sin \theta$
15	$\sigma \cdot 35 \cdot K$
	$5\cos \theta + 2(2.7+Lo)\sin \theta$
20	$\sigma \cdot 72 \cdot K$
	$6\cos \theta + 2(2.9+Lo)\sin \theta$
25	$\sigma \cdot 120 \cdot K$
	$6\cos \theta + 2(3.4+Lo)\sin \theta$
32	$\sigma \cdot 210 \cdot K$
	$7\cos \theta + 2(4.2+Lo)\sin \theta$
40	$\sigma \cdot 400 \cdot K$
	$8\cos \theta + 2(5.1+Lo)\sin \theta$

5. Inclined operation (at right angle to direction of operation)

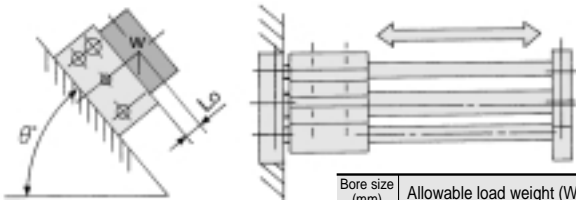

Lo: Distance from mounting surface to load center of gravity (cm)

Bore size (mm)	Allowable load weight (WA)(kg)
6	$\sigma \cdot 5.44$
	$3.2+2(1.9+Lo)\sin \theta$
10	$\sigma \cdot 12.0$
	$4+2(2.2+Lo)\sin \theta$
15	$\sigma \cdot 36.4$
	$5.2+2(2.7+Lo)\sin \theta$
20	$\sigma \cdot 74.4$
	$6.2+2(2.9+Lo)\sin \theta$
25	$\sigma \cdot 140$
	$7+2(3.4+Lo)\sin \theta$
32	$\sigma \cdot 258$
	$8.6+2(4.2+Lo)\sin \theta$
40	$\sigma \cdot 520$
	$10.4+2(5.1+Lo)\sin \theta$

6. Load center offset in operating direction (Lo)

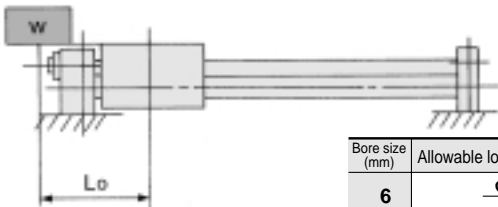

Lo: Distance from slide block center to load center of gravity (cm)

Bore size (mm)	Allowable load weight (WA)(kg)
6	$\sigma \cdot 2.55$
	$Lo+3$
10	$\sigma \cdot 5.25$
	$Lo+3.5$
15	$\sigma \cdot 17.5$
	$Lo+5.0$
20	$\sigma \cdot 36$
	$Lo+6.0$
25	$\sigma \cdot 60$
	$Lo+6.0$
32	$\sigma \cdot 105$
	$Lo+7.0$
40	$\sigma \cdot 200$
	$Lo+8.0$

7. Horizontal operation (pushing load, pusher)

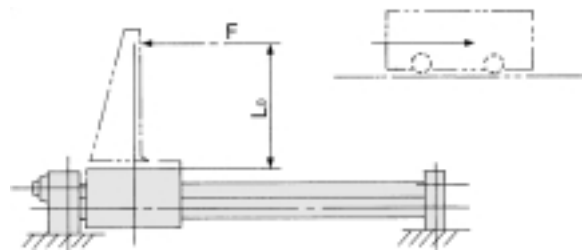

F: Drive (from slide block to position Lo) resistance force (kg)

Lo: Distance from mounting surface to load center of gravity (cm)

Bore size (mm)	6	10	15	20
Allowable load weight (WA)(kg)	$\frac{\sigma \cdot 2.55}{1.9+Lo}$	$\frac{\sigma \cdot 5.25}{2.2+Lo}$	$\frac{\sigma \cdot 17.5}{2.7+Lo}$	$\frac{\sigma \cdot 36}{2.9+Lo}$
	Bore size (mm)	25	32	40
Allowable load weight (WA)(kg)	$\frac{\sigma \cdot 60}{3.4+Lo}$	$\frac{\sigma \cdot 105}{4.2+Lo}$	$\frac{\sigma \cdot 200}{5.1+Lo}$	

8. Horizontal operation (load, lateral offset Lo)

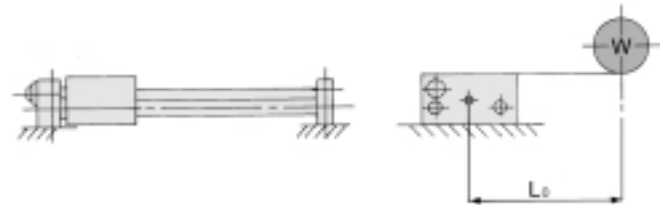

Lo: Distance from mounting surface to load center of gravity (cm)

Bore size (mm)	6	10	15	20
Allowable load weight (WA)(kg)	$\frac{\sigma \cdot 3.80}{3.2+Lo}$	$\frac{\sigma \cdot 8.40}{4+Lo}$	$\frac{\sigma \cdot 25.48}{5.2+Lo}$	$\frac{\sigma \cdot 52.1}{6.2+Lo}$
	Bore size (mm)	25	32	40
Allowable load weight (WA)(kg)	$\frac{\sigma \cdot 98}{7.0+Lo}$	$\frac{\sigma \cdot 180}{8.6+Lo}$	$\frac{\sigma \cdot 364}{10.4+Lo}$	

Series CY1S

Model Selection Method 4

Precautions on Design (3)

Vertical Operation

When operating a load vertically, it should be operated within the allowable load weight and maximum operating pressure shown in the table below.

Use caution, as operating above the prescribed values may lead to dropping of the load.

Bore size (mm)	Model	Allowable load weight (Wv) (kg)	Max. operating pressure (Pv) (MPa)
6	CY1S 6H	1.0	0.55
10	CY1S10H	2.7	0.55
15	CY1S15H	7.0	0.65
	CY1S15L	4.1	0.40
20	CY1S20H	11.0	0.65
	CY1S20L	7.0	0.40
25	CY1S25H	18.5	0.65
	CY1S25L	11.2	0.40
32	CY1S32H	30.0	0.65
	CY1S32L	18.2	0.40
40	CY1S40H	47.0	0.65
	CY1S40L	29.0	0.40

Note) Use caution, as there is a possibility of breaking the magnetic coupling if operated above the maximum operating pressure.

Intermediate Stops

1) Intermediate stopping of load with an external stopper, etc.

When stopping a load in mid-stroke using an external stopper (adjustment bolt, etc.), operate within the operating pressure limits shown in the table below. Use caution, as operation at a pressure exceeding these limits can result in breaking of the magnetic coupling.

(1MPa: Approx.10.2kgf/cm²)

Bore size (mm)	Model	Operating pressure limit for intermediate stop (Ps) (MPa)
6	CY1S 6H	0.55
10	CY1S10H	0.55
15	CY1S15H	0.65
	CY1S15L	0.40
20	CY1S20H	0.65
	CY1S20L	0.40
25	CY1S25H	0.65
	CY1S25L	0.40
32	CY1S32H	0.65
	CY1S32L	0.40
40	CY1S40H	0.65
	CY1S40L	0.40

2) Intermediate stopping of load with an air pressure circuit

When stopping a load using an air pressure circuit, operate at or below the kinetic energy shown in the table below. Use caution, as operation when exceeding the allowable value can result in breaking of the magnetic coupling.

(Reference values)

Bore size (mm)	Model	Allowable kinetic energy for intermediate stop (Es) (J)
6	CY1S 6H	0.007
10	CY1S10H	0.03
15	CY1S15H	0.13
	CY1S15L	0.076
20	CY1S20H	0.24
	CY1S20L	0.16
25	CY1S25H	0.45
	CY1S25L	0.27
32	CY1S32H	0.88
	CY1S32L	0.53
40	CY1S40H	1.53
	CY1S40L	0.95

Series CY1S

Construction

Slider type/Slide bearing

CY1S6 to 40

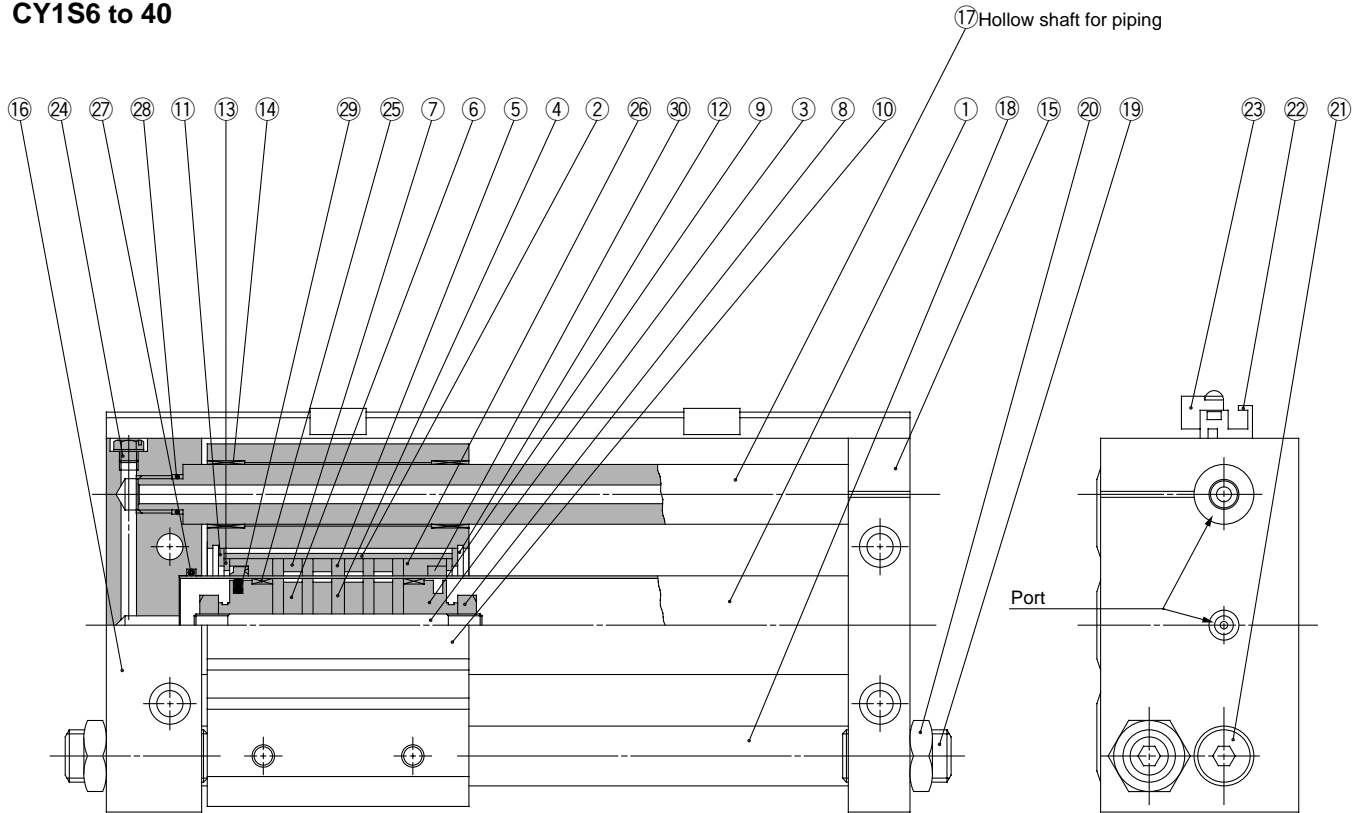

Parts list

No.	Description	Material	Note
1	Cylinder tube	Stainless steel	
2	External slider tube	Aluminum alloy	
3	Shaft	Stainless steel	
4	Piston side yoke	Rolled steel plate	Zinc chromated
5	External slider side yoke	Rolled steel plate	Zinc chromated
6	Magnet A	Rare earth magnet	
7	Magnet B	Rare earth magnet	
8	Piston nut	Carbon steel	Zinc chromated
9	Piston	Aluminum alloy ^{Note)}	Chromated
10	Slide block	Aluminum alloy	Hard anodized
11	Slider spacer	Rolled steel plate	Nickel plated
12	Snap ring	Carbon tool steel	Nickel plated
13	Spacer	Rolled steel plate	Nickel plated
14	Bushing	Oil retaining bearing material	
15	Plate A	Aluminum alloy	Hard anodized
16	Plate B	Aluminum alloy	Hard anodized
17	Guide shaft A	Carbon steel	Hard chrome plated
18	Guide shaft B	Carbon steel	Hard chrome plated
19	Adjustment bolt	Chrome molybdenum steel	
20	Hexagon nut	Carbon steel	
21	Hexagon socket head screw	Chrome molybdenum steel	Nickel plated
22	Switch mounting rail	Aluminum alloy	

Note) Brass for $\phi 6$, $\phi 10$, $\phi 15$

Parts list

No.	Description	Material	Note
23	Auto switch	—	
24	Plug	Brass	
* 25	Wear ring A	Special resin	
* 26	Wear ring B	Special resin	
* 27	Cylinder tube gasket	NBR	
* 28	Guide shaft gasket	NBR	
* 29	Piston seal	NBR	
* 30	Scraper	NBR	

Replacement parts: Seal kits

Bore size (mm)	Order No.	Content
6	CY1S6-PS-N	Nos. 26, 27, 28, 29 above
10	CY1S10-PS-N	Nos. 25, 26, 27, 28, 29, 30 above
15	CY1S15-PS-N	
20	CY1S20-PS-N	
25	CY1S25-PS-N	
32	CY1S32-PS-N	
40	CY1S40-PS-N	

* Seal kits are sets consisting of items 25 through 30, and can be ordered using the order number for each bore size.

Dimensions 

Slider type/Slide bearing

CY1S6, 10

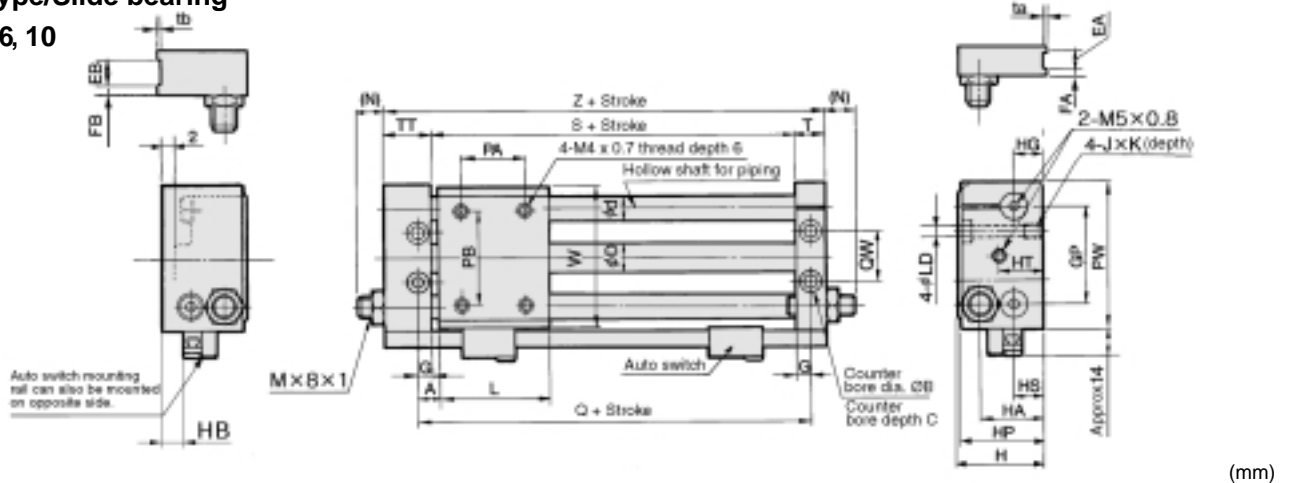

Model	A	B	C	D	d	EA	EB	FA	FB	G	GP	H	HA	*HB	HG	HP	HS	HT
CY1S6 CDY1S6	6	6.5	3	7.6	8	-	-	-	-	5	32	27	19	4	8	26	8	17
CY1S10 CDY1S10	7.5	8	4	12	10	6	12	3	5	6.5	40	34	25.5	10	12	33	14	18

Model	JxK	L	LD	(N)	*PA	PB	PW	Q	QW	S	T	TT	ta	tb	W	Z
CY1S6 CDY1S6	M4 x 0.7 x 6.5	40	3.5	10	25	25	50	52	16	42	10	16	-	-	46	68
CY1S10 CDY1S10	M5 x 0.8 x 9.5	45	4.3	9.5	25	38	60	60	24	47	12.5	20.5	0.5	1.0	58	80

* PA dimensions are for split from center. HB dimensions are for CDY1S.

CY1S15, ø20 to ø40

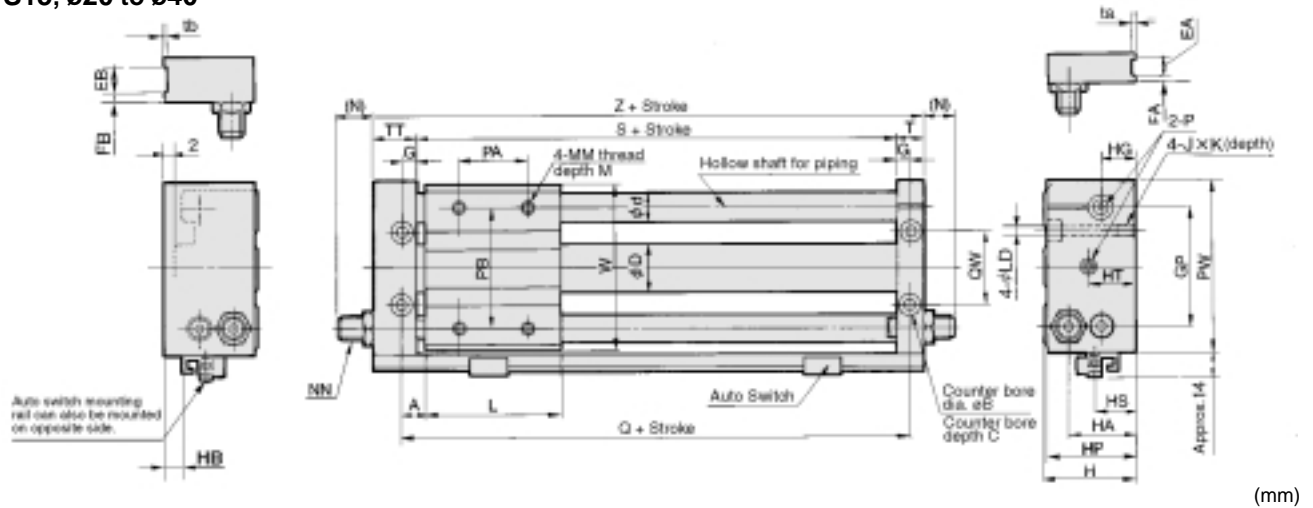

Model	A	B	C	D	d	EA	EB	FA	FB	G	GP	H	HA	*HB	HG	HP	HS	HT	J x K	L
CY1S15 CDY1S15	7.5	9.5	5	16.6	12	6	13	3	6	6.5	52	40	29	1	13	39	15	21	M6 x 1.0 x 9.5	60
CY1S20 CDY1S20	10	9.5	5.2	21.6	16	-	-	-	-	8.5	62	46	36	4.5	17	45	25.5	20	M6 x 1.0 x 9.5	70
CY1S25 CDY1S25	10	11	6.5	26.4	16	8	14	4	7	8.5	70	54	40	9	20	53	23	20	M8 x 1.25 x 10	70
CY1S32 CDY1S32	12.5	14	8	33.6	20	8	16	5	7	9.5	86	66	46	13	24	64	27	24	M10 x 1.5 x 15	85
CY1S40 CDY1S40	12.5	14	8	41.6	25	10	20	5	10	10.5	104	76	57	17	25	74	31	25	M10 x 1.5 x 15	95

Model	LD	M	MM	(N)	NN	P	*PA	PB	PW	Q	QW	S	T	TT	ta	tb	W	Z
CY1S15 CDY1S15	5.6	8	M5 x 0.8	7.5	M8 x 1.0	M5 x 0.8	30	50	75	75	30	62	12.5	22.5	0.5	1	72	97
CY1S20 CDY1S20	5.6	10	M6 x 1.0	9.5	M10 x 1	Rc(PT)1/8	40	70	90	90	38	73	16.5	25.5	-	-	87	115
CY1S25 CDY1S25	7	10	M6 x 1.0	11	M14 x 1.5	Rc(PT)1/8	40	70	100	90	42	73	16.5	25.5	0.5	1	97	115
CY1S32 CDY1S32	8.7	12	M8 x 1.25	11.5	M20 x 1.5	Rc(PT)1/8	40	75	122	110	50	91	18.5	28.5	0.5	1	119	138
CY1S40 CDY1S40	8.7	12	M8 x 1.25	10.5	M20 x 1.5	Rc(PT)1/4	65	105	145	120	64	99	20.5	35.5	1	1	142	155

* PA dimensions are for split from center. HB dimensions are for CDY1S.

	CDY1S6	SCY1S, #1	CDY1S25	SCY1S, #4
	CDY1S10	SCY1S, #2	CDY1S32	SCY1S, #5
	CDY1S15	SCY1S, #3	CDY1S40	SCY1S, #6
	CDY1S20	SCY1S20, #1		

Series CY1S

Shock Absorber Specifications/Series RB

Applicable rodless cylinder	6 CY1S10 15	CY1S20	CY1S25	CY1S³² 40	
Shock absorber model	RB0805	RB1006	RB1411	RB2015	
Maximum energy absorption: J {kgf·m}	0.98 {0.1}	3.92 {0.4}	14.7 {1.5}	58.8 {6}	
Stroke absorption: mm	5	6	11	15	
Impact speed: m/s	0.05 to 5				
Max. operating frequency: cycle/min ^{Note)}	80	70	45	25	
Ambient temperature range	-10 to 80°C				
Spring force: N {kgf}	When extended	1.96 {0.2}	4.22 {0.43}	6.86 {0.7}	8.34 {0.85}
	When compressed	3.83 {0.39}	6.18 {0.63}	15.3 {1.56}	20.50 {2.09}

Note) Indicates time of maximum energy absorption per cycle. Therefore, the operating frequency can be increased according to the energy absorption.

With Shock Absorber/Dimensions

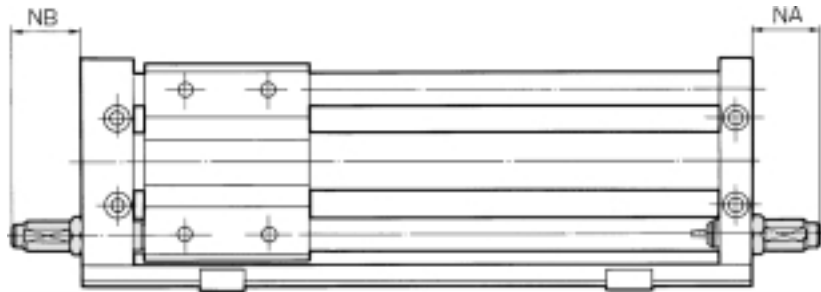

(mm)

Model	Applicable shock absorber	NA	NB
C□Y1S 6	RB0805	30	24
C□Y1S10		27	19
C□Y1S15		27	17
C□Y1S20	RB1006	29	20
C□Y1S25	RB1411	49	40
C□Y1S32	RB2015	52	42
C□Y1S40		51	36

Auto Switches/Proper Mounting Position for Stroke End Detection

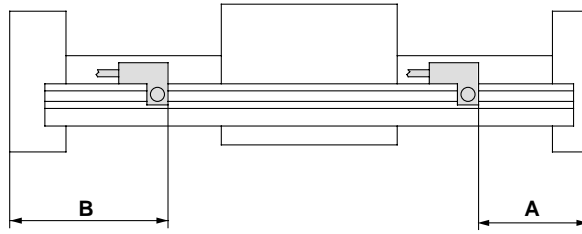

(mm)

Auto switch model Bore size (mm)	Dimension A				Dimension B			
	D-A73/A80	D-A72 D-A7□H/A80H D-A73C/A80C D-F7□/J79 D-J79C D-F7□V	D-F7□W/J79W D-F7□WV D-F7LF (Note 2) D-F79F D-F7BAL	D-F7NTL	D-A73/A80	D-A72 D-A7□H/A80H D-A73C/A80C D-F7□/J79 D-J79C D-F7□V	D-F7□W/J79W D-F7□WV D-F7LF (Note 2) D-F79F D-F7BAL	D-F7NTL
6	27.5	28	32	33	40.5	40	36	35
10	35	35.5	39.5	40.5	45	44.5	40.5	39.5
15	34.5	35	39	40	62.5	62	58	57
20	64	64.5	68.5	69.5	50	49.5	45.5	44.5
25	44	44.5	48.5	49.5	71	70.5	66.5	65.5
32	55	55.5	59.5	60.5	83	82.5	78.5	77.5
40	61	61.5	65.5	66.5	94	93.5	89.5	88.5

Note 1) 50mm is the minimum stroke available with 2 auto switches mounted. In case of a stroke less than this, contact SMC.

Note 2) Model D-F7LF cannot be mounted on bore sizes ø6 and ø10.

Auto switch operating range

(mm)

Auto switch model Bore size (mm)	D-A7□/A80 D-A7□H/A80H D-A73C/A80C	D-F7□/J79 D-J79C D-F7□V D-F7NTL D-F7□W/J79W D-F7□WV D-F7BAL	D-F7LF D-F79F
6	6	3	4.5
10	6	3	4.5
15	6	4	4.5
20	6	3	4.5
25	6	3	4.5
32	6	3	4.5
40	6	3.5	4.5

Note) Operating ranges are standards including hysteresis, and are not guaranteed. Large variations may occur depending on the surrounding environment. (variations on the order of ±30%)

Auto Switch Mounting

1N·m: Approx. 10.2kgf·cm

When mounting an auto switch, the switch mounting screw should be screwed into a hexagon nut (M3 x 0.5) which has been inserted into the groove of the switch rail. (Tightening torque should be about 0.05 to 0.1N·m (0.51 to 1.02kgf·cm).)

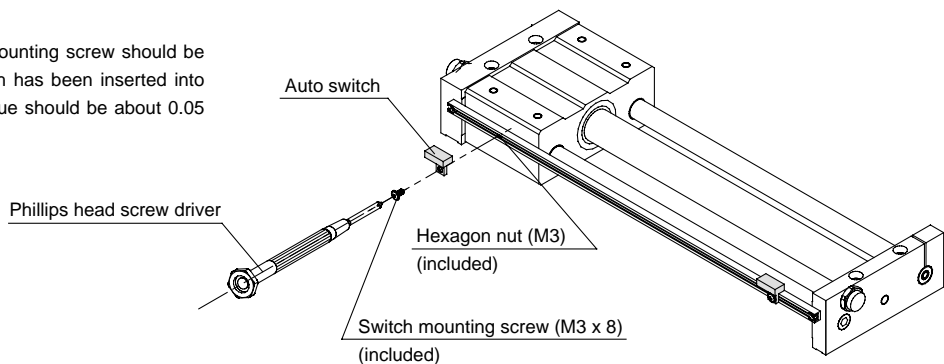

⚠ Specific product Precautions

Be sure to read before handling. Refer to pages 72 through 75 for safety instructions and actuator precautions.

Operation

⚠ Warning

1. Use caution in the space between the plates and the slide block.

Take sufficient care as fingers and hands, etc. may be injured if caught while the cylinder is in operation.

2. Do not apply a load to a cylinder which is greater than the allowable value in the selection data.

Mounting

⚠ Caution

1. Avoid operation with the external slider fixed to a mounting surface.

The cylinder should be operated with the plates fixed to a mounting surface.

2. Perform mounting so that the external slider will operate through the entire stroke at the minimum operating pressure.

If the mounting surface is not flat, the guides will be warped, increasing the minimum operating pressure and causing premature wear of the bearings. Therefore, mounting should be performed so that the external slider will operate through the entire stroke at the minimum operating pressure. A mounting surface with a high degree of flatness is desired, but in cases where this cannot be adequately confirmed, shim adjustment, etc. should be performed.

Disassembly & Maintenance

⚠ Warning

1. Use caution as the attractive power of the magnets is very strong.

When removing the external slider and piston slider from the cylinder tube for maintenance, etc., handle with caution, since the magnets installed in each slider have very strong attractive power.

⚠ Caution

1. Use caution when taking off the external slider, as the piston slider will be directly attracted to it.

When removing the external slider or piston slider from the cylinder tube, first force the sliders out of their magnetically coupled positions and then remove them individually when there is no longer any holding force. If they are removed when still magnetically coupled, they will be directly attracted to one another and will not come apart.

2. Since the magnetic holding force can be changed (for example, from CY1S25L to CY1S25H), contact SMC if this is necessary.

3. Do not disassemble the magnetic components (piston slider, external slider).

This can cause a loss of holding force and malfunction.

4. When disassembling to replace the seals and wear ring, refer to the separate disassembly instructions.

5. Note the direction of the external slider and piston slider.

Since the external slider and piston slider are directional for $\phi 6$, $\phi 10$ and holding force type L, refer to the drawings below when performing disassembly or maintenance. Put the external slider and piston slider together, and insert the piston slider into the cylinder tube so that they will have the correct positional relationship as shown in Figure 1. If they align as shown in Figure 2, insert the piston slider after turning it around 180° . If the direction is not correct, it will be impossible to obtain the specified holding force.

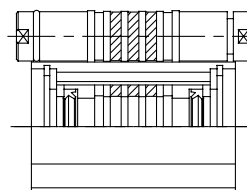

Figure 1. Correct position

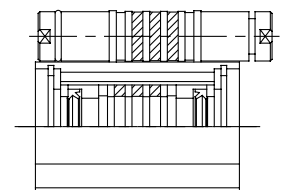

Figure 2. Incorrect position

Example for $\phi 15$ with holding power type L

Series CY1L

Slider Type/Ball Bushing



How to Order

Ball bushing

CY1L 25 H 300 A72

Slider type (ball bushing)

Bore size

6	6mm	25	25mm
10	10mm	32	32mm
15	15mm	40	40mm
20	20mm		

Magnetic holding force

Refer to the magnet holding force table on p. 35.

Standard stroke

Refer to the standard stroke table on p. 35.

Number of auto switches

Nil	2pcs.
S	1pc.
n	"n" pcs.

Auto switch type

Nil	Without auto switch
-----	---------------------

* Refer to the table below for applicable auto switch types.

Adjustment type

Nil	With adjustment bolt
B	With shock absorber (2pcs.)
BS	With shock absorber (with plate ^(A)) * Installed on Side A at time of shipment.

Applicable auto switch types / Refer to "Auto Switch Guide" (E274-A) for further details on auto switch units.

Type	Special function	Electrical entry	Indicator light	Wiring (output)	Load voltage		Auto switch no.		Lead wire length (m) ^(Note 1)				Applicable load						
					DC	AC	Electrical entry direction	Vertical	Lateral	0.5 (Nil)	3 (L)	5 (Z)	None (N)						
Reed switch	—	Grommet	Yes	3 wire (NPN equiv.)	—	5V	—	—	A76H	●	●	—	—	IC circuit	—				
				—	—	200V	A72	A72H	●	●	—	—	—	—					
		Connector	No	2 wire	24V	5V, 12V	100V or less	A80	A80H	●	●	—	—	IC circuit	Relay PLC				
				—	—	—	A73C	—	●	●	●	●	—	—					
Solid state switch	—	Grommet	Yes	3 wire (NPN)	24V	5V, 12V	—	F7NV	F79	●	●	○	—	IC circuit	Relay PLC				
				3 wire (PNP)				F7PV	F7P	●	●	○	—	—					
		Connector	No	2 wire				12V	F7BV	J79	●	●	○	—		—			
				—				—	—	J79C	—	●	●	●		●	—		
		Diagnostic indication (2 color indicator)	Grommet	Yes				3 wire (NPN)	24V	5V, 12V	—	F7NWV	F79W	●		●	○	—	IC circuit
								3 wire (PNP)				—	F7PW	●		●	○	—	—
	2 wire				12V	F7BWV	J79W	●				●	○	—		—			
	—				—	—	F7BA	—				●	○	—		—			
	—				—	—	F7NT	—				●	○	—		IC circuit			
	—				—	—	F79F	●				●	○	—		—			
	Water resistant (2 color indicator)	Grommet	Yes	4 wire (NPN)	24V	5V, 12V	—	—	F7LF ^(Note 3)	●	●	○	—	—					
	With timer			—				—	—	—	—	—	—	—					
With diagnostic output (2 color indicator)	—			—				—	—	—	—	—	—						
—	—			—				—	—	—	—	—	—						
—	—			—				—	—	—	—	—	—						
Latch type with diagnostic output (2 color indicator)	—			—				—	—	—	—	—	—						

Note 1) Lead wire length symbol 0.5m Nil (Example) A80C
 3m L (Example) A80CL
 5m Z (Example) A80CZ
 None ... N (Example) A80CN

Note 2) Solid state auto switches marked with a "○" are produced upon receipt of order.

Note 3) Type D-F7LF cannot be mounted on bore sizes ø6 and ø10.

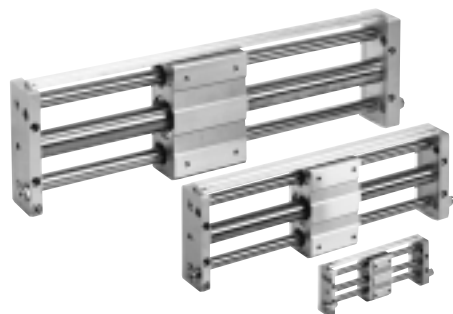

Long life design

Ball bushings having excellent trafficability are used in the guides.

Ball bushing: With grease cup

Easy piping and wiring

Hollow shafts are used, and centralization of ports on one side makes piping easy. Auto switches can be mounted through the use of special switch rails.

Shock absorbers and adjustment bolt are standard equipment

Impacts at stroke end due to high speed use can be absorbed, and fine adjustment of the stroke is possible.

Adjustment bolt amount of adjustment

Bore size (mm)	Adjustment bolt amount of adjustment (both sides) (mm)
6	12
10	11
15	7
20	11
25	10
32	11
40	9

* Since the cylinder is in an intermediate stop condition when stroke adjustment is performed, use caution regarding the operating pressure and the kinetic energy of the load.

Principle Materials

Description	Material	Note
Cylinder tube	Stainless steel	-
Magnet	Rare earth magnet	-
Slide block	Aluminum alloy	Hard anodized

Models

Type	Bearing type	Model	Bore size (mm)	With auto switch	Adjustable type
Slider type	Ball bushing	CY1L	6, 10, 15, 20 25, 32, 40	D-A7/A8 D-F7/J7	Adjustment bolt Shock absorber

Specifications

Fluid	Air
Proof pressure	1.05MPa {10.7kgf/cm ² }
Maximum operating pressure	0.7MPa {7.1kgf/cm ² }
Minimum operating pressure	0.18MPa {1.8kgf/cm ² }
Ambient and fluid temperature	-10 to 60°C
Piston speed ^{Note)}	50 to 1000mm/s
Cushion	Shock absorber/Rubber bumper
Lubrication	Non-lube
Stroke length tolerance	0 to 250st: $^{+1.0}_0$, 251 to 1000st: $^{+1.4}_0$, 1001st to : $^{+1.8}_0$
Mounting orientation	Unrestricted
Standard equipment	Auto switch mounting rail

Note) In the case of a model with auto switch where an auto switch is mounted at an intermediate position, the maximum detectable piston speed is controlled by the response time of the load (relays, sequence controller, etc.).

Standard Stroke Table

Bore size (mm)	Standard stroke (mm)	Maximum available stroke (mm)
6	50, 100, 150, 200	300
10	50, 100, 150, 200, 250, 300	500
15	50, 100, 150, 200, 250, 300, 350 400, 450, 500	750
20		1000
25	100, 150, 200, 250, 300, 350 400, 450, 500, 600, 700, 800	1500
32		
40	100, 150, 200, 250, 300, 350 400, 450, 500, 600, 700, 800 900, 1000	1500

Magnetic Holding Force (N)

1N: Approx. 0.102kgf								
Bore size (mm)	6	10	15	20	25	32	40	
Holding force type	H type	19.6	53.9	137	231	363	588	922
	L type	-	-	81.4	154	221	358	569

Weight Table

		(kg)						
Bore size (mm)		6	10	15	20	25	32	40
Basic weight	CY1L□H	0.324	0.580	1.10	1.85	2.21	4.36	4.83
	CY1L□L	-	-	1.02	1.66	2.04	4.18	4.61
Additional weight per 50mm of stroke		0.044	0.077	0.104	0.138	0.172	0.267	0.406

Calculation method/Example: CY1L32H-500

Basic weight 4.36kg Additional weight 0.267/50st Cylinder stroke 500st
4.36 + 0.267 x 500 ÷ 50 = 7.03kg

Series CY1L Model Selection Method 1

E: Kinetic energy of load (J)

$$E = \frac{W}{2} \times \left(\frac{V}{1000} \right)^2$$

Es: Allowable kinetic energy for intermediate stop using an air pressure circuit (J)

Ps: Operating pressure limit for intermediate stop using an external stopper, etc. (MPa)

Pv: Maximum operating pressure for vertical operation (MPa)

WA: Allowable load weight based on these operating conditions (kg)

Wv: Allowable load weight for vertical operation (kg)

σ: Stroke coefficient

$$\sigma = \frac{\text{Load weight within stroke}}{\text{Maximum load weight}}$$

Operating conditions

- W: Load weight (kg)
- P: Operating pressure (MPa)
- L_o: Distance from slide block mounting surface to work piece center of gravity (cm)
- V: Speed (mm/s)
- Stroke (mm)
- Mode of operation (horizontal, inclined, vertical)

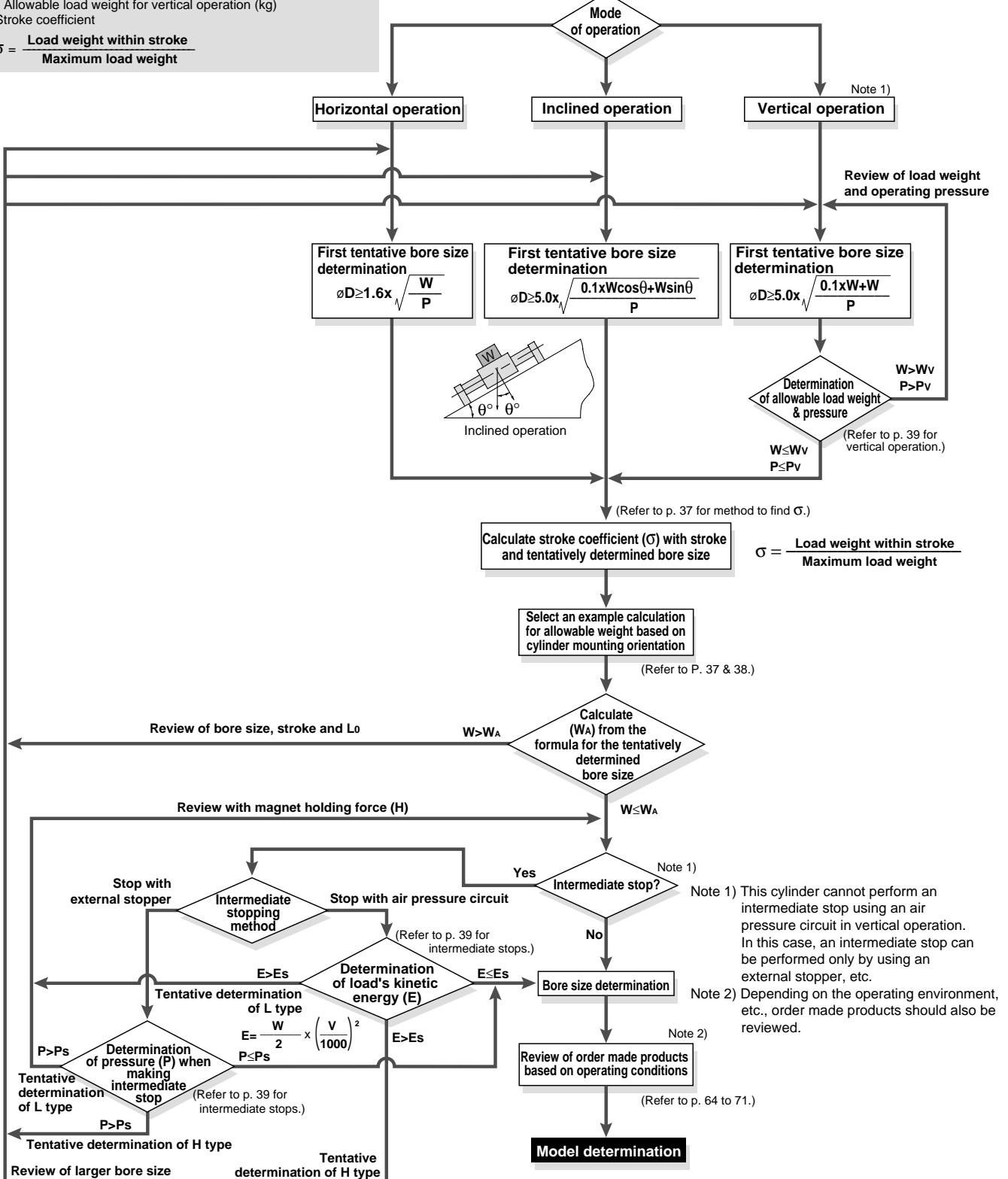

Series CY1L

Model Selection Method 2

Precautions on Design (1)

How to Find σ when Selecting the Allowable Load Weight

Since the maximum load weight with respect to the cylinder stroke changes as shown in the table below, σ should be considered as a coefficient determined in accordance with to each stroke.

Example) for CY1L25 □-650

- (1) Maximum load weight = 20kg
- (2) Load weight for 650st = 13.6kg
- (3) $\sigma = \frac{13.6}{20} = 0.68$ is the result.

Calculation formula for s ($\sigma \leq 1$)

ST: Stroke (mm)

Model	CY1L6	CY1L10	CY1L15
$\sigma =$	1	$10^{(0.86-1.3 \times 10^{-3} \times \text{ST})}$ 3	$10^{(1.5-1.3 \times 10^{-3} \times \text{ST})}$ 7
Model	CY1L20	CY1L25	CY1L32
$\sigma =$	$10^{(1.71-1.3 \times 10^{-3} \times \text{ST})}$ 12	$10^{(1.98-1.3 \times 10^{-3} \times \text{ST})}$ 20	$10^{(2.26-1.3 \times 10^{-3} \times \text{ST})}$ 30
Model	CY1L40		
$\sigma =$	$10^{(2.48-1.3 \times 10^{-3} \times \text{ST})}$ 50		

Note) Calculate with $\sigma=1$ for all applications up to $\phi 10-300\text{mmST}$, $\phi 15-500\text{mmST}$, $\phi 20-500\text{mmST}$, $\phi 25-500\text{mmST}$, $\phi 32-600\text{mmST}$ and $\phi 40-600\text{mmST}$.

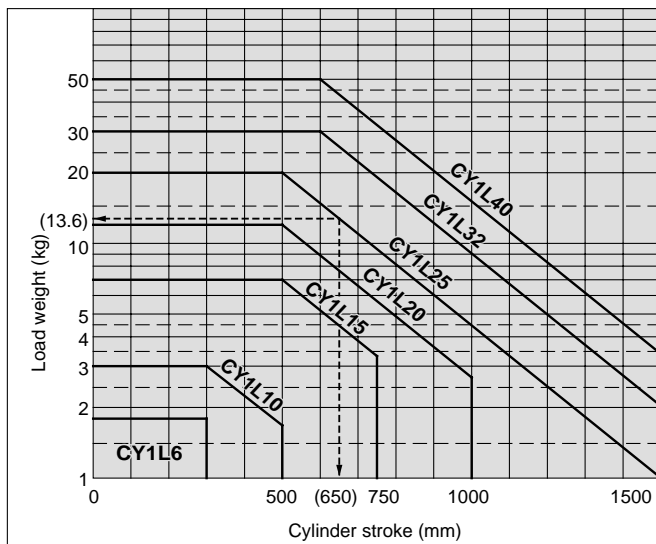

Examples of Allowable Load Weight Calculation Based on Cylinder Mounting Orientation

1. Horizontal operation (floor mounting)

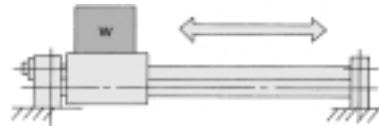

Maximum load weight (center of slide block)

Bore size (mm)	6	10	15	20	25	32	40
Max. load weight (kg)	1.8	3	7	12	20	30	50
Stroke (max)	to 300st	to 300st	to 500st	to 500st	to 500st	to 600st	to 600st

The above maximum load weight values will change with the stroke length for each cylinder size, due to limitation from warping of the guide shafts. (Take note of the coefficient σ .) Moreover, depending on the operating direction, the allowable load weight may be different from the maximum load weight.

2. Horizontal operation (wall mounting)

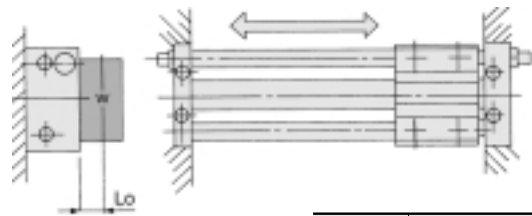

Lo: Distance from mounting surface to load center of gravity (cm)

Bore size (mm)	Allowable load weight (WA)(kg)
6	$\sigma \cdot 6.48$ $6.8+2Lo$
10	$\sigma \cdot 15.0$ $8.9+2Lo$
15	$\sigma \cdot 45.5$ $11.3+2Lo$
20	$\sigma \cdot 101$ $13.6+2Lo$
25	$\sigma \cdot 180$ $15.2+2Lo$
32	$\sigma \cdot 330$ $18.9+2Lo$
40	$\sigma \cdot 624$ $22.5+2Lo$

3. Vertical operation

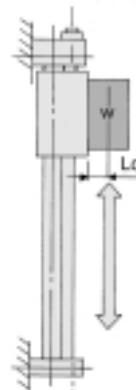

Bore size (mm)	Allowable load weight (WA)(kg)
6	$\sigma \cdot 1.53$ $1.6+Lo$
10	$\sigma \cdot 5.00$ $1.95+Lo$
15	$\sigma \cdot 15.96$ $2.4+Lo$
20	$\sigma \cdot 31.1$ $2.8+Lo$
25	$\sigma \cdot 54.48$ $3.1+Lo$
32	$\sigma \cdot 112.57$ $3.95+Lo$
40	$\sigma \cdot 212.09$ $4.75+Lo$

Lo: Distance from mounting surface to load center of gravity (cm)
Note) A safety factor should be considered to prevent dropping.

Series CY1L Model Selection Method 3

Precautions on Design 2

Examples of Allowable Load Weight Calculation Based on Cylinder Mounting Orientation

4. Inclined operation (in direction of operation)

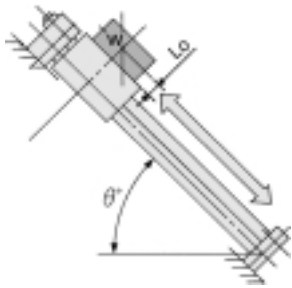

Angle	to 45°	to 60°	to 75°	to 90°
k	1	0.9	0.8	0.7

Angle coefficient (k) $k = [\text{to } 45^\circ (= \theta)] = 1$,
 $[\text{to } 60^\circ] = 0.9$, $[\text{to } 75^\circ] = 0.8$,
 $[\text{to } 90^\circ] = 0.7$

L_o : Distance from mounting surface to load center of gravity (cm)

Bore size (mm)	Allowable load weight (WA)(kg)
6	$\sigma \cdot 4.05 \cdot K$
	$1.7 \cos \theta + 2(1.6 + L_o) \sin \theta$
10	$\sigma \cdot 10.2 \cdot K$
	$2.8 \cos \theta + 2(1.95 + L_o) \sin \theta$
15	$\sigma \cdot 31.1 \cdot K$
	$2.9 \cos \theta + 2(2.4 + L_o) \sin \theta$
20	$\sigma \cdot 86.4 \cdot K$
	$6 \cos \theta + 2(2.8 + L_o) \sin \theta$
25	$\sigma \cdot 105.4 \cdot K$
	$3.55 \cos \theta + 2(3.1 + L_o) \sin \theta$
32	$\sigma \cdot 178 \cdot K$
	$4 \cos \theta + 2(3.95 + L_o) \sin \theta$
40	$\sigma \cdot 361.9 \cdot K$
	$5.7 \cos \theta + 2(4.75 + L_o) \sin \theta$

5. Inclined operation (at right angle to direction of operation)

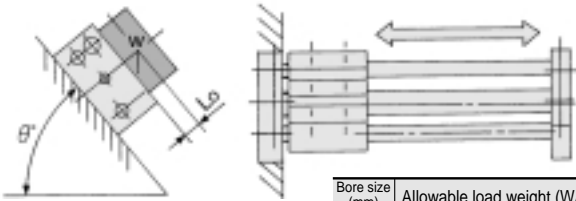

L_o : Distance from slide block center to load center of gravity (cm)

Bore size (mm)	Allowable load weight (WA)(kg)
6	$\sigma \cdot 6.48$
	$3.6 + 2(1.6 + L_o) \sin \theta$
10	$\sigma \cdot 15$
	$5 + 2(1.95 + L_o) \sin \theta$
15	$\sigma \cdot 45.5$
	$6.5 + 2(2.4 + L_o) \sin \theta$
20	$\sigma \cdot 115$
	$8 + 2(2.8 + L_o) \sin \theta$
25	$\sigma \cdot 180$
	$9 + 2(3.1 + L_o) \sin \theta$
32	$\sigma \cdot 330$
	$11 + 2(3.95 + L_o) \sin \theta$
40	$\sigma \cdot 624$
	$13 + 2(4.75 + L_o) \sin \theta$

6. Load center offset in operating direction (L_o)

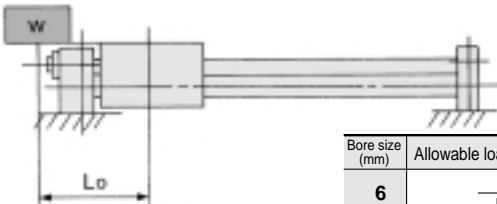

L_o : Distance from slide block center to load center of gravity (cm)

Bore size (mm)	Allowable load weight (WA)(kg)
6	$\sigma \cdot 2$
	$L_o + 1.7$
10	$\sigma \cdot 5.6$
	$L_o + 2.8$
15	$\sigma \cdot 13.34$
	$L_o + 2.9$
20	$\sigma \cdot 43.2$
	$L_o + 6$
25	$\sigma \cdot 46.15$
	$L_o + 3.55$
32	$\sigma \cdot 80$
	$L_o + 4$
40	$\sigma \cdot 188.1$
	$L_o + 5.7$

7. Horizontal operation (pushing load, pusher)

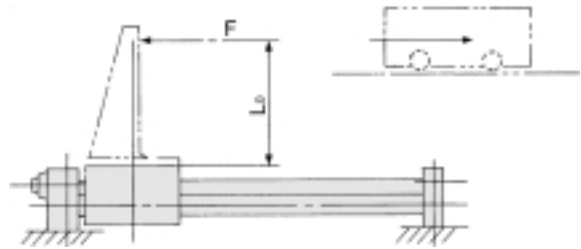

F : Drive (from slide block to position L_o) resistance force (kg)
 L_o : Distance from mounting surface to load center of gravity (cm)

Bore size (mm)	6	10	15	20
Allowable load weight (WA)(kg)	$\frac{\sigma \cdot 2.72}{1.6 + L_o}$	$\frac{\sigma \cdot 5.55}{1.95 + L_o}$	$\frac{\sigma \cdot 15.96}{2.4 + L_o}$	$\frac{\sigma \cdot 41.7}{2.8 + L_o}$
Bore size (mm)	25	32	40	
Allowable load weight (WA)(kg)	$\frac{\sigma \cdot 58.9}{3.1 + L_o}$	$\frac{\sigma \cdot 106.65}{3.95 + L_o}$	$\frac{\sigma \cdot 228}{4.75 + L_o}$	

8. Horizontal operation (load, lateral offset L_o)

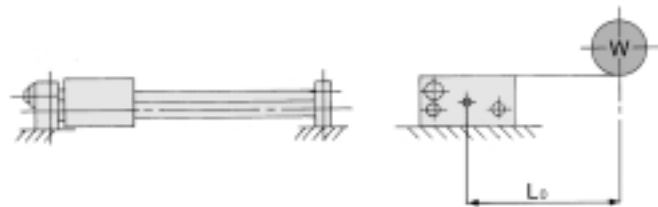

L_o : Distance from center of slide block to load center of gravity (cm)

Bore size (mm)	6	10	15	20
Allowable load weight (WA)(kg)	$\frac{\sigma \cdot 6.48}{3.6 + L_o}$	$\frac{\sigma \cdot 15}{5 + L_o}$	$\frac{\sigma \cdot 45.5}{6.5 + L_o}$	$\frac{\sigma \cdot 80.7}{8 + L_o}$
Bore size (mm)	25	32	40	
Allowable load weight (WA)(kg)	$\frac{\sigma \cdot 144}{9 + L_o}$	$\frac{\sigma \cdot 275}{11 + L_o}$	$\frac{\sigma \cdot 520}{13 + L_o}$	

Series CY1L

Model Selection Method 4

Precautions on Design (3)

Vertical Operation

When operating a load vertically, it should be operated within the allowable load weight and maximum operating pressure shown in the table below.

Use caution, as operating above the prescribed values may lead to dropping of the load.

Bore size (mm)	Model	Allowable load weight (Wv) (kg)	Max. operating pressure (Pv) (MPa)
6	CY1L 6H	1.0	0.55
10	CY1L10H	2.7	0.55
15	CY1L15H	7.0	0.65
	CY1L15L	4.1	0.40
20	CY1L20H	11.0	0.65
	CY1L20L	7.0	0.40
25	CY1L25H	18.5	0.65
	CY1L25L	11.2	0.40
32	CY1L32H	30.0	0.65
	CY1L32L	18.2	0.40
40	CY1L40H	47.0	0.65
	CY1L40L	29.0	0.40

Note) Use caution, as there is a possibility of breaking the magnetic coupling if operated above the maximum operating pressure.

Intermediate Stops

1) Intermediate stopping of load with an external stopper, etc.

When stopping a load in mid-stroke using an external stopper (adjustment bolt, etc.), operate within the operating pressure limits shown in the table below. Use caution, as operation at a pressure exceeding these limits can result in breaking of the magnetic coupling.

(1MPa: Approx. 10.2kgf/cm²)

Cylinder Bore size (mm)	Model	Operating pressure limit for intermediate stop (Ps) (MPa)
6	CY1L 6H	0.55
10	CY1L10H	0.55
15	CY1L15H	0.65
	CY1L15L	0.40
20	CY1L20H	0.65
	CY1L20L	0.40
25	CY1L25H	0.65
	CY1L25L	0.40
32	CY1L32H	0.65
	CY1L32L	0.40
40	CY1L40H	0.65
	CY1L40L	0.40

2) Intermediate stopping of load with an air pressure circuit

When stopping a load using an air pressure circuit, operate at or below the kinetic energy shown in the table below. Use caution, as operation when exceeding the allowable value can result in breaking of the magnetic coupling.

(Reference values)

Bore size (mm)	Model	Allowable kinetic energy for intermediate stop (Es) (J)
6	CY1L 6H	0.007
10	CY1L10H	0.03
15	CY1L15H	0.13
	CY1L15L	0.076
20	CY1L20H	0.24
	CY1L20L	0.16
25	CY1L25H	0.45
	CY1L25L	0.27
32	CY1L32H	0.88
	CY1L32L	0.53
40	CY1L40H	1.53
	CY1L40L	0.95

Series CY1L

Construction

Slider type/Ball bushing

CY1L6

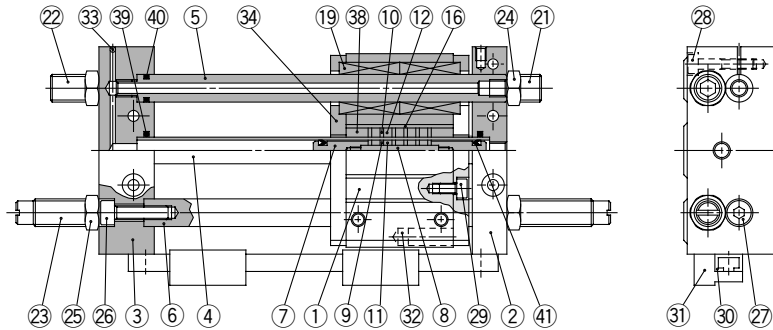

CY1L10 to 40

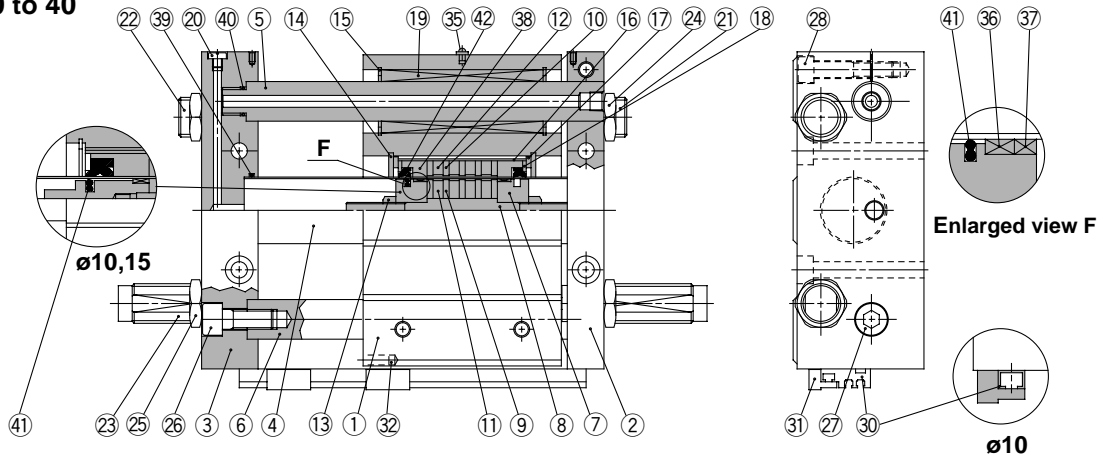

Parts list

No.	Description	Material	Note
1	Slide block	Aluminum alloy	Hard anodized
2	Plate A	Aluminum alloy	Hard anodized
3	Plate B	Aluminum alloy	Hard anodized
4	Cylinder tube	Stainless steel	
5	Guide shaft A	Carbon steel	Hard chrome plated
6	Guide shaft B	Carbon steel	Hard chrome plated
7	Piston	Aluminum alloy ^{Note 1)}	Chromated
8	Shaft	Stainless steel	
9	Piston side yoke	Rolled steel plate	Zinc chromated
10	External slider side yoke	Rolled steel plate	Zinc chromated
11	Magnet A	Rare earth magnet	
12	Magnet B	Rare earth magnet	
13	Piston nut	Carbon steel	Zinc chromated $\varnothing 25$ to $\varnothing 40$
14	Snap ring	Carbon tool steel	Nickel plated
15	Snap ring	Carbon tool steel	Nickel plated
16	External slider tube	Aluminum alloy	
17	Slider spacer	Rolled steel plate	Nickel plated
18	Spacer	Rolled steel plate	Nickel plated
19	Ball bushing	—	
20	Plug	Brass	$\varnothing 25$, $\varnothing 32$, $\varnothing 40$ only
21	Adjustment bolt A	Chrome molybdenum steel	Nickel plated
22	Adjustment bolt B	Chrome molybdenum steel	Nickel plated
23	Shock absorber	—	
24	Hexagon nut	Carbon steel	Nickel plated
25	Hexagon nut	Carbon steel	Nickel plated
26	Hexagon socket head screw	Chrome molybdenum steel	Nickel plated
27	Hexagon socket head screw	Chrome molybdenum steel	Nickel plated
28	Hexagon socket head screw	Chrome molybdenum steel	Nickel plated

Note 1) Brass for $\varnothing 6$, $\varnothing 10$, $\varnothing 15$

Parts list

No.	Description	Material	Note
29	Hexagon socket head screw	Chrome molybdenum steel	Nickel plated
30	Switch mounting rail	Aluminum alloy	
31	Auto switch	—	
32	Magnet for auto switch	Rare earth magnet	
33	Steel ball	—	$\varnothing 6, \varnothing 10, \varnothing 15$ only
34	Side cover	Carbon steel	$\varnothing 6$ only
35	Grease cup	Carbon steel	$\varnothing 15$ or larger
*36	Wear ring A	Special resin	
*37	Wear ring	Special resin	
*38	Wear ring B	Special resin	
*39	Cylinder tube gasket	NBR	
*40	Guide shaft gasket	NBR	
*41	Piston seal	NBR	
*42	Scraper	NBR	

Replacement parts: Seal kits

Bore size (mm)	Order No.	Content
6	CY1L6-PS-N	Nos. 38, 39, 40, 41 above
10	CY1L10-PS-N	Nos. 36, 38, 39, 40, 41, 42 above
15	CY1L15-PS-N	above
20	CY1L20-PS-N	Nos.
25	CY1L25-PS-N	36, 37, 38, 39, 40, 41, 42 above
32	CY1L32-PS-N	
40	CY1L40-PS-N	

* Seal kits are sets consisting of items 36 through 42, and can be ordered using the order number for each bore size.

Dimensions



Slider type/Ball bushing

CY1L6, 10

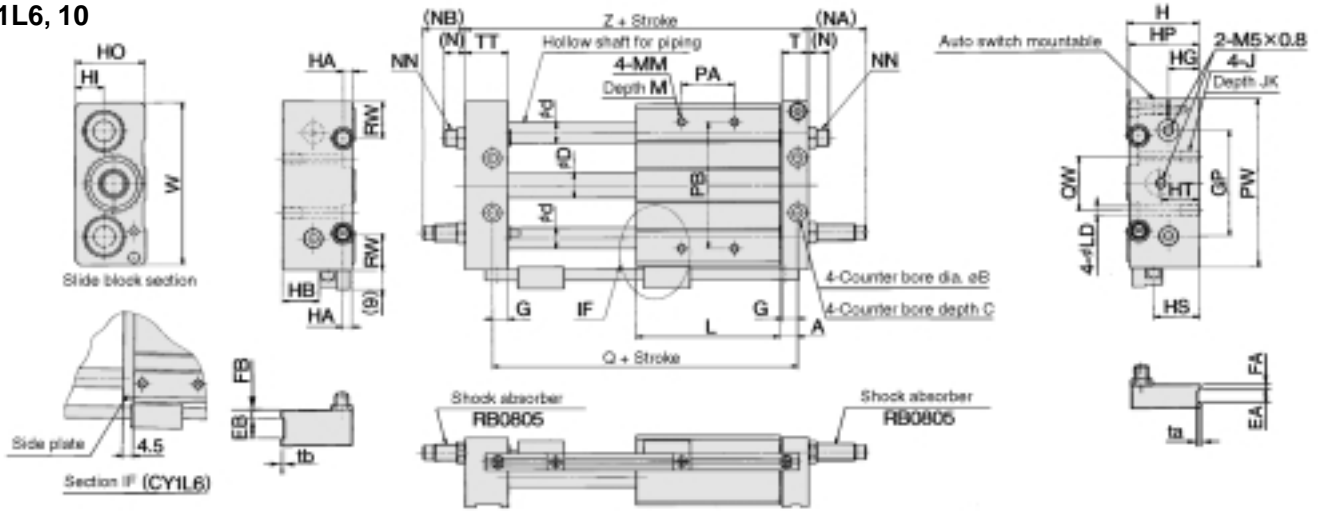

Model	A	B	C	D	d	EA	EB	FA	FB	G	GP	H	HA	HB	HG	HI	HO	HP	HS	HT	J	JK
CY1L6	7	6.5	3	7.6	8	-	-	-	-	6	36	27	6	10	11	9	25	26	14	16	M4 x 0.7	6.5
CY1L10	8.5	8	4	12	10	6	12	3	5	7.5	50	34	6	17.5	14.5	13.5	33	33	21.5	18	M5 x 0.8	9.5

Model	L	LD	M	MM	(N)	(NA)	(NB)	NN	*PA	PB	PW	Q	QW	RW	T	TT	ta	tb	W	Z
CY1L6	40	3.5	6	M4 x 0.7	10	30	24	M8 x 1.0	24	40	60	54	20	12	10	16	-	-	56	68
CY1L10	68	4.3	8	M4 x 0.7	9.5	27	19	M8 x 1.0	30	60	80	85	26	17.5	12.5	20.5	0.5	1.0	77	103

*PA dimensions are for split from center.

CY1L15, 20, 25, 32, 40

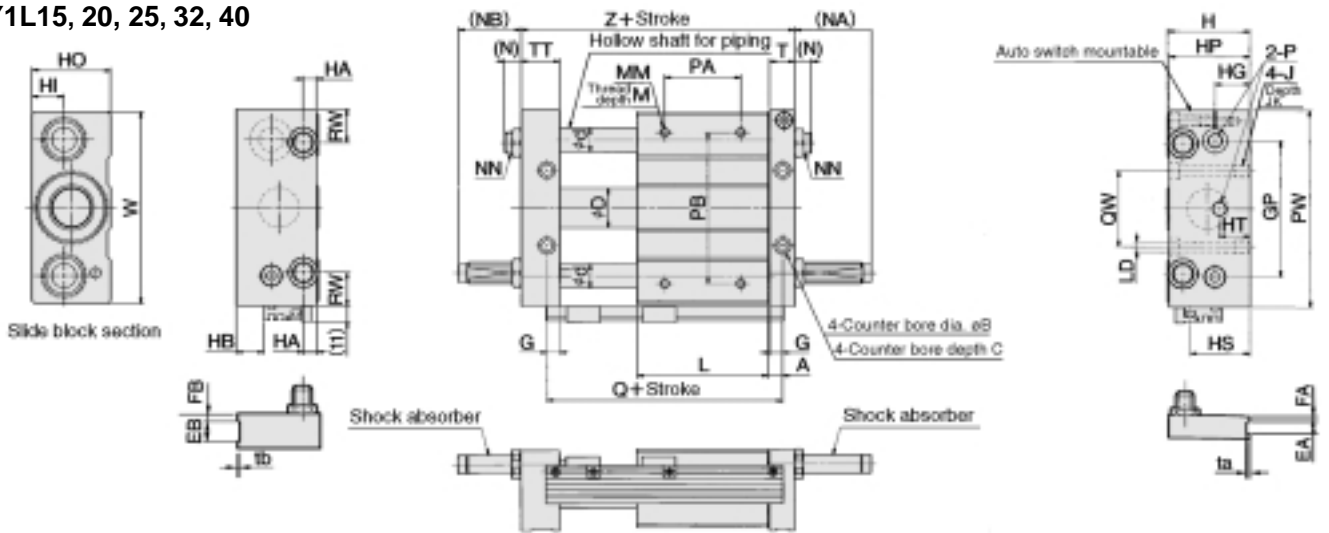

Model	A	B	C	D	d	EA	EB	FA	FB	G	GP	H	HA	HB	HG	HI	HO	HP	HS	HT	J	JK	L	LD
CY1L15	7.5	9.5	5	16.6	12	6	13	3	6	6.5	65	40	6.5	4	16	14	38	39	25	16	M6 x 1.0	9.5	75	5.6
CY1L20	9.5	9.5	5.2	21.6	16	-	-	-	-	8.5	80	46	9	10	18	16	44	45	31	20	M6 x 1.0	10	86	5.6
CY1L25	9.5	11	6.5	26.4	16	8	14	4	7	8.5	90	54	9	18	23	21	52	53	39	20	M8 x 1.25	10	86	7
CY1L32	10.5	14	8	33.6	20	8	16	5	7	9.5	110	66	12	26.5	26.5	24.5	64	64	47.5	25	M10 x 1.5	15	100	9.2
CY1L40	11.5	14	8	41.6	25	10	20	5	10	10.5	130	78	12	35	30.5	28.5	76	74	56	30	M10 x 1.5	15	136	9.2

Model	M	MM	(N)	(NA)	(NB)	NN	P	*PA	PB	PW	Q	QW	RW	T	ta	tb	TT	W	Z	Shock absorber
CY1L15	8	M5 x 0.8	7.5	27	17	M8 x 1.0	M5x0.8	45	70	95	90	30	15	12.5	0.5	1.0	22.5	92	112	RB0805
CY1L20	10	M6 x 1.0	10	29	20	M10 x 1.0	Rc(PT)1/8	50	90	120	105	40	28	16.5	-	-	25.5	117	130	RB1006
CY1L25	10	M6 x 1.0	11	49	40	M14 x 1.5	Rc(PT)1/8	60	100	130	105	50	22	16.5	0.5	1.0	25.5	127	130	RB1411
CY1L32	12	M8 x 1.25	11.5	52	42	M20 x 1.5	Rc(PT)1/8	70	120	160	121	60	33	18.5	0.5	1.0	28.5	157	149	RB2015
CY1L40	12	M8 x 1.25	10.5	51	36	M20 x 1.5	Rc(PT)1/4	90	140	190	159	84	35	20.5	1.0	1.0	35.5	187	194	RB2015

*PA dimensions are for split from center.

- CY1L6 SCY1L, #1 (#1 + #7)
- CY1L10 SCY1L, #2 (#2 + #7)
- CY1L15 SCY1L, #3 (#3 + #7)
- CY1L25 SCY1L, #4 (#4 + #7)
- CY1L32 SCY1L, #5 (#5 + #7)
- CY1L40 SCY1L, #6 (#6 + #7)

Series CY1L

Shock Absorber Specifications/Series RB

Applicable rodless cylinder	CY1L10 ⁶ 15	CY1L20	CY1L25	CY1L ³² 40	
Shock absorber model	RB0805	RB1006	RB1411	RB2015	
Maximum energy absorption: J {kgf·m}	0.98 {0.1}	3.92 {0.4}	14.7 {1.5}	58.8 {6}	
Stroke absorption: mm	5	6	11	15	
Impact speed: m/s	0.05 to 5				
Max. operating frequency: cycle/min ^{Note)}	80	70	45	25	
Ambient temperature range	-10 to 80°C				
Spring force: N {kgf}	When extended	1.96 {0.2}	4.22 {0.43}	6.86 {0.7}	8.34 {0.85}
	When compressed	3.83 {0.39}	6.18 {0.63}	15.3 {1.56}	20.50 {2.09}

Note) Indicates time of maximum energy absorption per cycle. Therefore, the operating frequency can be increased according to the energy absorption.

Auto Switches/Proper Mounting Position for Stroke End Detection

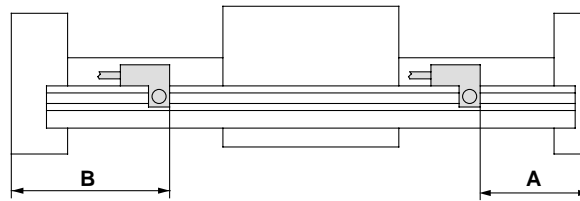

(mm)

Auto switch model Bore size (mm)	Dimension A				Dimension B			
	D-A73/A80	D-A72 D-A7□H/A80H D-A73C/A80C D-F7□/J79 D-J79C D-F7□V	D-F7□W/J79W D-F7□WV D-F7LF ^{Note 2)} D-F79F D-F7BAL	D-F7NTL	D-A73/A80	D-A72 D-A7□H/A80H D-A73C/A80C D-F7□/J79 D-J79C D-F7□V	D-F7□W/J79W D-F7□WV D-F7LF ^{Note 2)} D-F79F D-F7BAL	D-F7NTL
6	23	23.5	27.5	28.5	45	44.5	40.5	39.5
10	58	58.5	62.5	63.5	45	44.5	40.5	39.5
15	65	65.5	69.5	70.5	47	46.5	42.5	41.5
20	76	76.5	80.5	81.5	54	53.5	49.5	48.5
25	76	76.5	80.5	81.5	54	53.5	49.5	48.5
32	92	92.5	96.5	97.5	57	56.5	52.5	51.5
40	130	130.5	134.5	135.5	64	63.5	59.5	58.5

Note 1) 50mm is the minimum stroke available with 2 auto switches mounted. In case of a stroke less than this, contact SMC.

Note 2) Model D-F7LF cannot be mounted on bore sizes ø6 and ø10.

Auto switch operating range

(mm)

Auto switch model Bore size (mm)	D-A7□/A80 D-A7□H/A80H D-A73C/A80C	D-F7□/J79 D-J79C D-F7□V D-F7NTL D-F7□W/J79W D-F7□WV D-F7BAL	D-F7LF D-F79F
6	6	3	4.5
10	6	3	4.5
15	6	4	4.5
20	6	3	4.5
25	6	3	4.5
32	6	3	4.5
40	6	3.5	4.5

Note) Operating ranges are standards including hysteresis, and are not guaranteed. Large variations may occur depending on the surrounding environment. (variations on the order of ±30%)

Auto Switch Mounting

IN m: Approx.10.2kgf·cm

When mounting an auto switch, the switch mounting screw should be screwed into a hexagon nut (M3 x 0.5) which has been inserted into the groove of the switch rail. (Tightening torque should be about 0.05 to 0.1N·m {0.51 to 1.02kgf·cm}.)

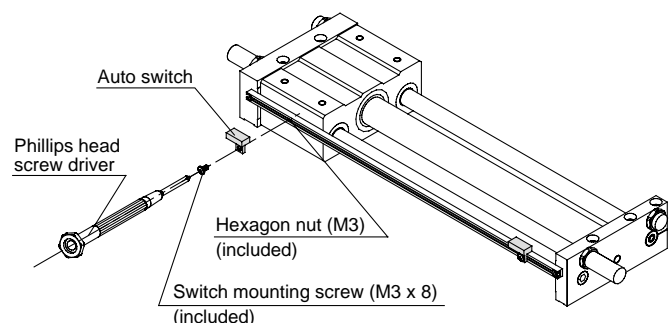

⚠ Specific product Precautions

Be sure to read before handling. Refer to pages 72 through 75 for safety instructions and actuator precautions.

Operation

⚠ Warning

1. Use caution in the space between the plates and the slide block.

Take sufficient care as fingers and hands, etc. may be injured if caught while the cylinder is in operation.

2. Do not apply a load to a cylinder which is greater than the allowable value in the selection data.

Mounting

⚠ Caution

1. Avoid operation with the external slider fixed to a mounting surface.

The cylinder should be operated with the plates fixed to a mounting surface.

2. Perform mounting so that the external slider will operate through the entire stroke at the minimum operating pressure.

If the mounting surface is not flat, the guides will be warped, increasing the minimum operating pressure and causing premature wear of the bearings. Therefore, mounting should be performed so that the external slider will operate through the entire stroke at the minimum operating pressure. A mounting surface with a high degree of flatness is desired, but in cases where this cannot be adequately confirmed, shim adjustment, etc. should be performed.

Disassembly & Maintenance

⚠ Warning

1. Use caution as the attractive power of the magnets is very strong.

When removing the external slider and piston slider from the cylinder tube for maintenance, etc., handle with caution, since the magnets installed in each slider have very strong attractive power.

⚠ Caution

1. Use caution when taking off the external slider, as the piston slider will be directly attracted to it.

When removing the external slider or piston slider from the cylinder tube, first force the sliders out of their magnetically coupled positions and then remove them individually when there is no longer any holding force. If they are removed when still magnetically coupled, they will be directly attracted to one another and will not come apart.

2. Since the magnetic holding force can be changed (for example, from CY1S25L to CY1S25H), contact SMC if this is necessary.

3. Do not disassemble the magnetic components (piston slider, external slider).

This can cause a loss of holding force and malfunction.

4. When disassembling to replace the seals and wear ring, refer to the separate disassembly instructions.

5. Note the direction of the external slider and piston slider.

Since the external slider and piston slider are directional for $\phi 6$, $\phi 10$ and holding force type L, refer to the drawings below when performing disassembly or maintenance. Put the external slider and piston slider together, and insert the piston slider into the cylinder tube so that they will have the correct positional relationship as shown in Figure 1. If they align as shown in Figure 2, insert the piston slider after turning it around 180° . If the direction is not correct, it will be impossible to obtain the specified holding force.

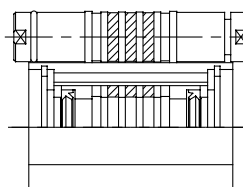

Figure 1. Correct position

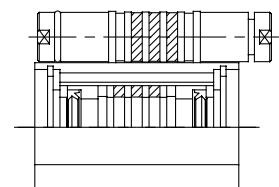

Figure 2. Incorrect position

Example for $\phi 15$ with holding force type L

Series CY1H

High Precision Guide Type

How to Order

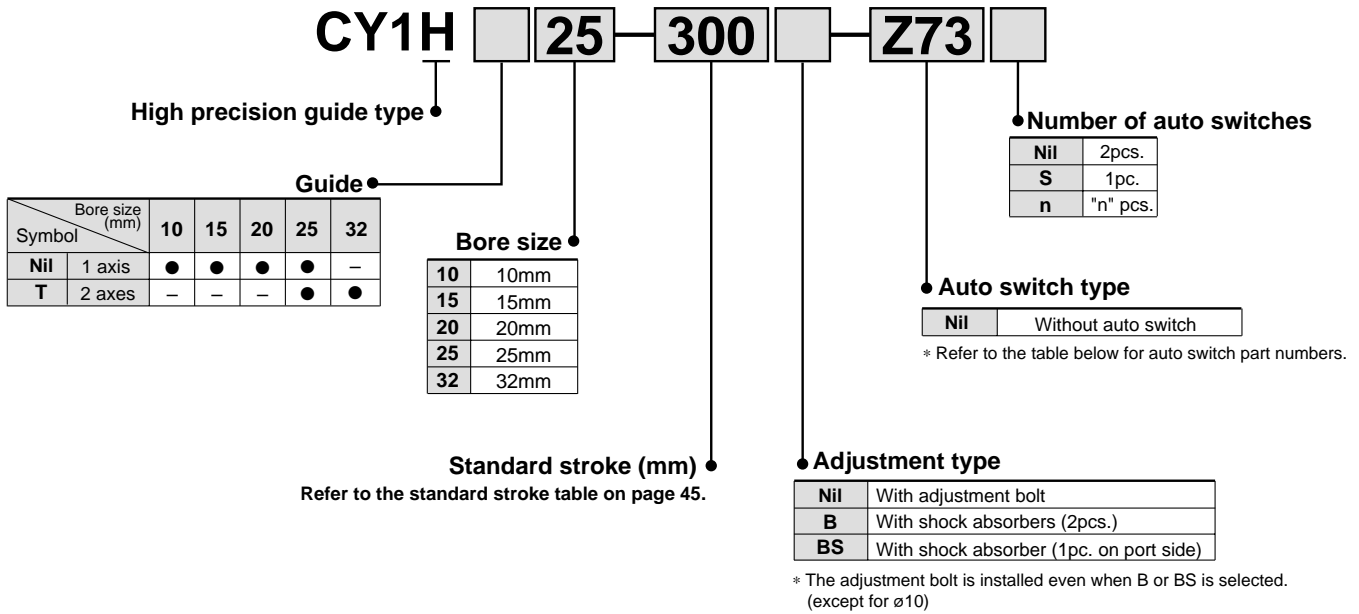

Applicable auto switch types

Refer to "Auto Switch Guide" (E274-A) for further details on auto switch units.
Refer to pages 60 and 61 for auto switch circuit diagrams.

Type	Special function	Electrical entry	Indicator light	Wiring (output)	Load voltage		Auto switch no.		Lead wire length (m) ^{Note 1)}			Applicable load	
					DC	AC	Electrical entry direction		0.5 (Nil)	3 (L)	5 (Z)		
Reed switch	—	Grommet	Yes	3 wire (NPN equiv.)	—	5V	—	Z76	●	●	—	IC circuit	—
				2 wire	24V	12V 5V, 12V	100V 100V or less	Z73 Z80	●	●	●	—	Relay PLC
Solid state switch	Diagnostic indication (2 color indicator)	Grommet	Yes	3 wire (NPN)	5V, 12V	—	Y69A	Y59A	●	●	○	IC circuit	Relay PLC
				3 wire (PNP)					12V	●	●		
				2 wire	5V, 12V		Y69B	Y59B		●	●	○	
				3 wire (NPN)			Y7NWV	Y7NW	●	●	○		
				3 wire (PNP)	Y7PWV		Y7PW	●	●	○			
				2 wire	12V		Y7BWV	Y7BW	●	●	○		

Note 1) Lead wire length symbol 0.5m Nil (Example) Y59A
3m L (Example) Y59AL
5m Z (Example) Y59AZ

Note 2) Solid state auto switches marked with a "○" are produced upon receipt of order.

Specifications



1MPa: Approx. 10.2kgf/cm²

Bore size mm	10	15	20	25	32
Fluid	Air				
Action	Double acting				
Maximum operating pressure	0.7MPa(7.1kgf/cm ²)				
Minimum operating pressure	0.2MPa(2.0kgf/cm ²)				
Proof pressure	1.05MPa(10.7kgf/cm ²)				
Ambient and fluid temperature	-10 to 60°C				
Piston speed	70 to 1000mm/s				
Cushion (external stopper)	Urethane bumpers on both sides (standard), Shock absorbers (optional)				
Lubrication	Non-lube				
Stroke length tolerance	0 to 1.8mm				
Piping type	Centralized piping				
Piping port size	M5x0.8		Rc(PT) ^{1/8}		

Standard Stroke Table

Bore size (mm)	Number of axes	Standard stroke (mm)	Maximum ^{Note)} available stroke (mm)
10	1 axis	100, 200, 300	500
15		100, 200, 300, 400, 500	750
20		100, 200, 300, 400, 500, 600	1000
25		100, 200, 300, 400, 500, 600, 800	1200
25	2 axes	100, 200, 300, 400, 500,	1500
32		600, 800, 1000	

Note) Contact SMC if the maximum stroke is exceeded.

Magnetic Holding Force

1N: Approx. 0.102kgf

Bore size (mm)	10	15	20	25	32
Holding force N	53.9	137	231	363	588

Theoretical Output Table

(N)

Bore size (mm)	Piston area (mm ²)	Operating pressure (MPa)					
		0.2	0.3	0.4	0.5	0.6	0.7
10	78	15	23	31	39	46	54
15	176	35	52	70	88	105	123
20	314	62	94	125	157	188	219
25	490	98	147	196	245	294	343
32	804	161	241	322	402	483	563

Note)

Theoretical output (N) = Pressure (MPa) x Piston area (mm²).

Weight Table

(kg)

Model	Standard stroke mm							
	100	200	300	400	500	600	800	1000
CY1H10	1.0	1.3	1.6	—	—	—	—	—
CY1H15	2.2	2.7	3.2	3.6	4.1	—	—	—
CY1H20	3.0	3.5	4.0	4.4	4.9	5.4	—	—
CY1H25	4.6	5.3	6.0	6.6	7.3	8.0	9.4	—
CY1HT25	5.1	6.2	7.3	8.3	9.4	10.4	12.5	14.6
CY1HT32	8.4	9.6	10.7	11.9	13.0	14.2	16.5	18.8

Shock Absorber Specifications

1J: Approx. 0.102kgf·m

Applicable cylinder size mm	10	15	20	25	32
Shock absorber model	RB0805	RB0806	RB1006	RB1411	RB2015
Maximum energy absorption J	0.98	2.94	3.92	14.7	58.8
Stroke absorption mm	5	6	6	11	15
Impact speed m/s	0.05 to 5				
*Max. operating frequency cycle/min	80		70	45	25
Spring force N	When extended		4.22	6.86	8.34
	When compressed		3.83	4.22	6.18
Weight g	15		25	65	150

* Indicates the time of maximum energy absorption per cycle. Therefore, the operating frequency can be increased according to the energy absorption.

Series CY1H

Stroke Adjustment

Loosen the round head Phillips Screws, and remove the top cover and dust covers (4pcs.).

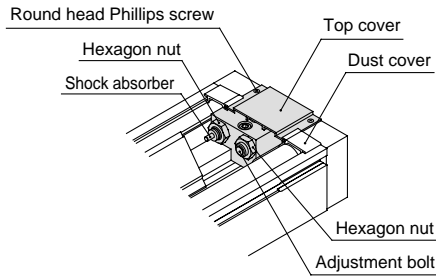

Loosen the hexagon nut, adjust the stroke with a hexagon wrench from the plate side, and secure by retightening the hexagon nut. When there is a shock absorber, loosen the hexagon nut, adjust the stroke, and then retighten the hexagon nut. Adjustment should be performed to make effective use of the shock absorber's absorption capacity, with its position relative to the adjustment bolt as shown in the drawing to the right.

⚠ Caution

If the effective stroke of the shock absorber is shortened by the stroke adjustment, its absorption capacity will be drastically reduced. Therefore, the adjustment bolt should be secured at a position where it projects about 0.5mm farther than the shock absorber.

Lock nut tightening torque N·m {kgf·m}

Model	For shock absorber	For adjustment bolt
CY1H10	1.67{0.17}	1.67
CY1H15		{0.17}
CY1H20	3.14{0.32}	3.14
CY1H25	10.8{1.1}	
CY1HT25	23.5{2.4}	

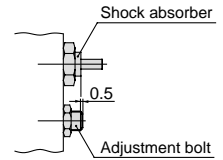

After completing the above adjustment, replace the top cover and dust covers back into place. The round head Phillips screws for securing the top cover should be tightened with a torque of 0.58N·m{0.06kgf·m}.

Series CY1H

Order Made Specifications 1

Contact SMC for detailed specifications, lead times and prices, etc.

E: Kinetic energy of load (J)

$$E = \frac{W}{2} \times \left(\frac{V}{1000} \right)^2$$

Es: Allowable kinetic energy for intermediate stop using an air pressure circuit (J)

Ps: Operating pressure limit for intermediate stop using an external stopper, etc. (MPa)

Pv: Maximum operating pressure for vertical operation (MPa)

Wv: Allowable load weight for vertical operation (kg)

α: Load factor

$$\Sigma\alpha = \frac{\text{Load weight (W)}}{\text{Max. load weight (Wmax)}} + \frac{\text{Static moment (M)}}{\text{Allowable static moment (Mmax)}} + \frac{\text{Dynamic moment (Me)}}{\text{Allowable dynamic moment (Memax)}}$$

Operating conditions

- W: Load weight (kg)
- V: Speed (mm/s)
- P: Operating pressure (MPa)
- Stroke (mm)
- Position of work piece center of gravity (m)
- Mode of operation (horizontal, inclined, vertical)

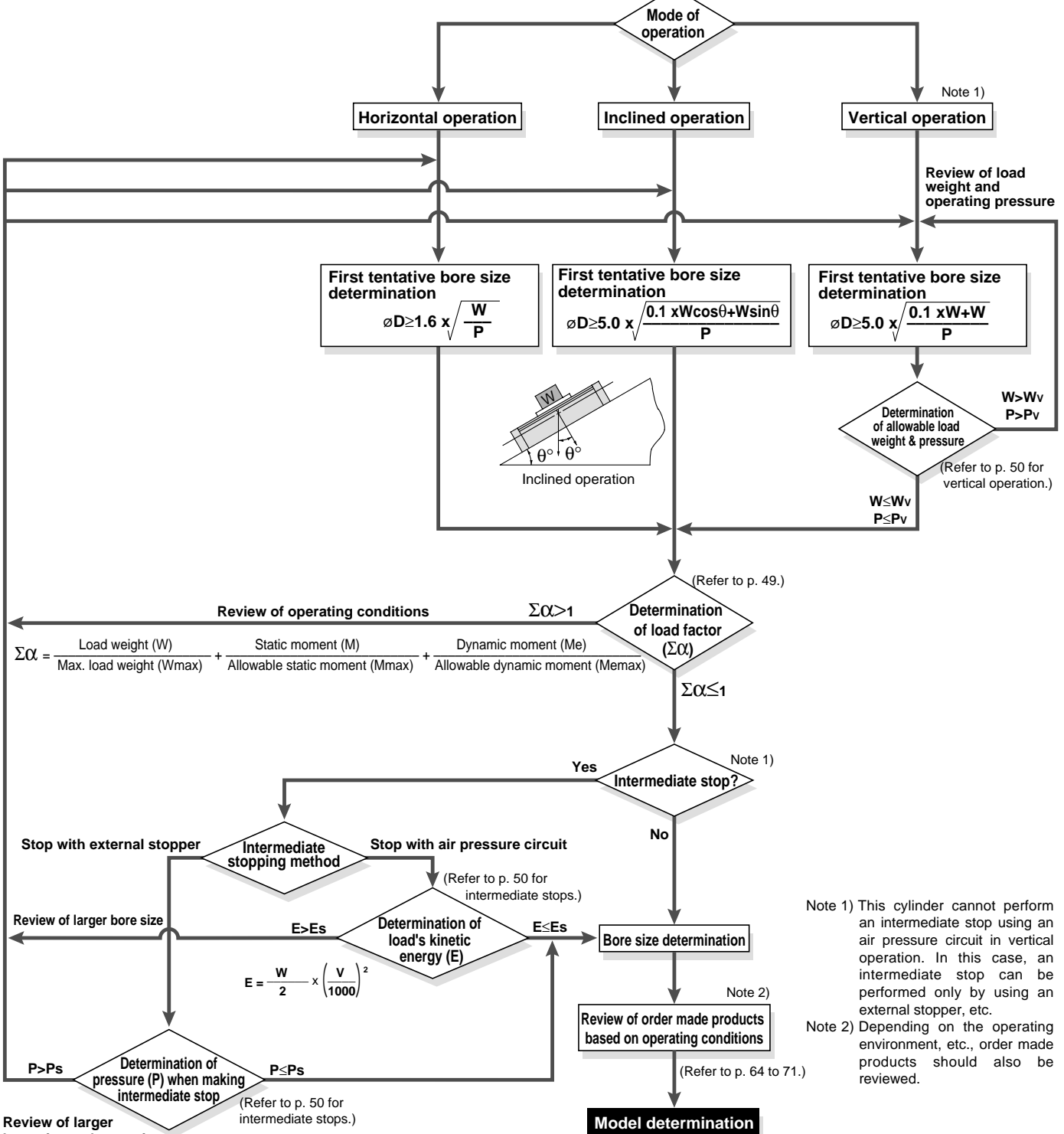

Note 1) This cylinder cannot perform an intermediate stop using an air pressure circuit in vertical operation. In this case, an intermediate stop can be performed only by using an external stopper, etc.

Note 2) Depending on the operating environment, etc., order made products should also be reviewed.

Review of larger bore size and operating pressure

Series CY1H

Model Selection Method 2

Precautions on Design (1)

The maximum load weight and allowable moment will differ depending on the work piece mounting method, cylinder mounting orientation and piston speed.

A determination of suitability for use is performed based on the operating limit values in the graphs with respect to operating conditions, but the total ($\sum \alpha_n$) of the load factors (α_n) for each weight and moment should not exceed 1.

$$\sum \alpha_n = \frac{\text{Load weight (W)}}{\text{Max. load weight (Wmax)}} + \frac{\text{Static moment (M)}}{\text{Allowable static moment (Mmax)}} + \frac{\text{Dynamic moment (Me)}}{\text{Allowable dynamic moment (Memax)}} \leq 1$$

Each of the values Wmax, Mmax and Memax are found in Graphs 1, 2 and 3 below.

Load weight

Max. load weight (kg)

Model	Wmax
CY1H10	4.0
CY1H15	9.0
CY1H20	16.0
CY1H25	25.0
CY1HT25	25.0
CY1HT32	40.0

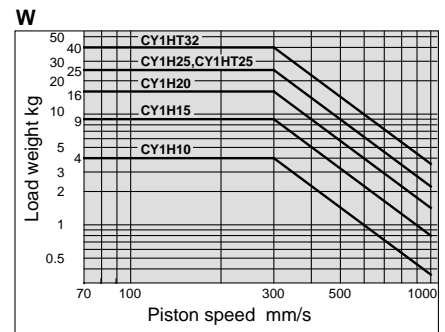
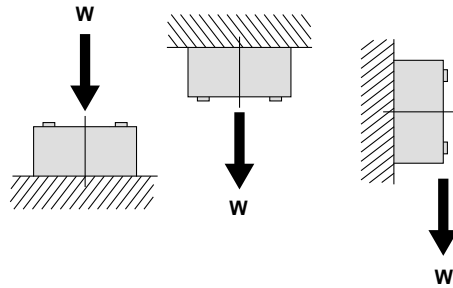

<Graph 1>

Moment

Allowable moment

(Static moment/Dynamic moment) (N·m)

Model	M1	M2	M3	Model	M1	M2	M3
CY1H10	1.5	2.5	1.5	CY1H25	28	26	28
CY1H15	10	16	10	CY1HT25	56	85	56
CY1H20	13	16	13	CY1HT32	64	96	64

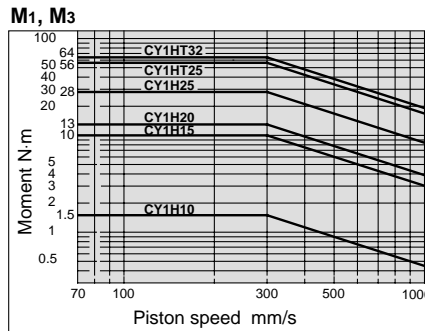
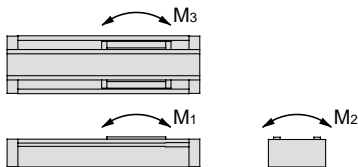

<Graph 2>

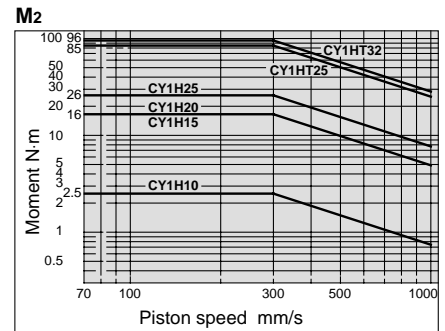

<Graph 3>

Static moment

Moment generated by the dead weight of the load even when the cylinder is stopped

■ Pitch moment

$$M_1 = W \cdot L$$

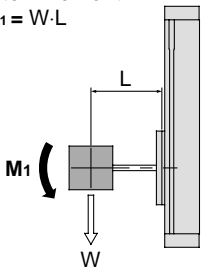

■ Roll moment

$$M_2 = W \cdot L$$

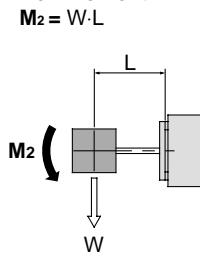

■ Yaw moment

$$M_3 = W(L-A)$$

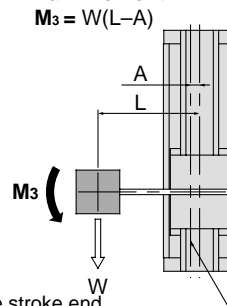

Model	A (mm)
CY1H10	15
CY1H15	17.5
CY1H20	19.5
CY1H25	23.5
CY1HT25	* 0
CY1HT32	* 0

* Since there are 2 guides, the guides' central axis and the cylinder's central axis are the same.

Dynamic moment

Moment generated by the load equivalent to the impact at the stroke end

$$We = \delta \cdot W \cdot V$$

$$V = 1.4Va$$

We: Load equivalent to impact [N]
 δ : Bumper coefficient
 With adjustment bolt (standard) = 4/100
 With shock absorber = 1/100
 W: Load weight [kg]
 V: Impact speed [mm/s]
 Va: Average speed [mm/s]

■ Pitch moment

$$Me_1 = *1/3 \cdot We \cdot L$$

* Average load coefficient

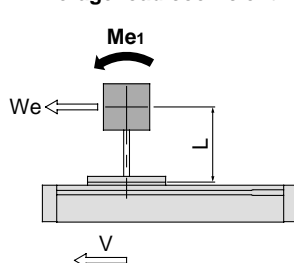

■ Yaw moment

$$Me_3 = *1/3 \cdot We (L-A)$$

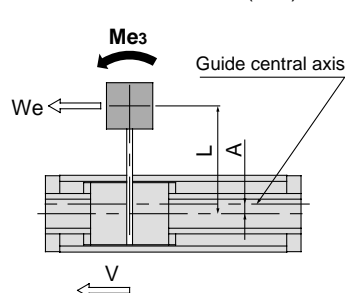

Model	A (mm)
CY1H10	15
CY1H15	17.5
CY1H20	19.5
CY1H25	23.5
CY1HT25	* 0
CY1HT32	* 0

* Since there are 2 guides, the guides' central axis and the cylinder's central axis are the same.

Series CY1H

Model Selection Method 3

Selection calculation

The selection calculation finds the load factors (α_n) of the items below, where the total ($\Sigma\alpha_n$) does not exceed 1.

$$\Sigma\alpha_n = \alpha_1 + \alpha_2 + \alpha_3 \leq 1$$

Item	Load factor α_n	Note
1. Max. load weight	$\alpha_1 = W/W_{max}$	Investigate W Wmax is the max. load weight for Va
2. Static moment	$\alpha_2 = M/M_{max}$	Investigate M1, M2, M3 Mmax is the allowable moment for Va
3. Dynamic moment	$\alpha_3 = Me/Me_{max}$	Investigate Me1, Me3 Memax is the allowable moment for V

V: Impact speed Va: Average speed

Calculation examples

Operating conditions

Cylinder: CY1H15
Cushion: Standard (adjustment bolt)
Mounting: Horizontal wall mounting
Speed (average): Va = 300 [mm/s]
Load weight: W = 1 [kg] (excluding weight of arm section)
L1 = 50 [mm]
L2 = 50 [mm]

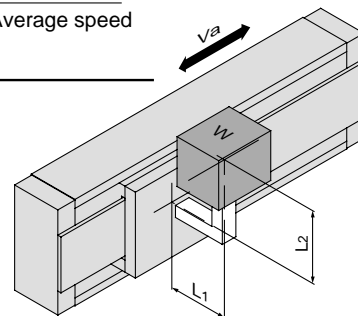

Item	Load factor α_n	Note
1. Maximum load weight	$\alpha_1 = W/W_{max}$ $= 1/9$ $= \mathbf{0.111}$	Investigate W. Find the value of Wmax when Va = 300mm/s from <Graph 1>.
2. Static moment	$M_2 = W \cdot L_1$ $= 10 \cdot 0.05$ $= 0.5 \text{ [N}\cdot\text{m]}$ $\alpha_2 = M_2/M_{2max}$ $= 0.5/16$ $= \mathbf{0.031}$	Investigate M2. Since M1 & M3 are not generated, investigation is unnecessary. Find the value of M2max when Va = 300mm/s from <Graph 3>.
3. Dynamic moment	From V = 1.4Va $We = \delta \cdot W \cdot V$ $= 4/100 \cdot 10 \cdot 1.4 \cdot 300$ $= 168 \text{ [N]}$ $Me_3 = 1/3 \cdot We \cdot (L_2 - A)$ $= 1/3 \cdot 168 \cdot 0.032$ $= 1.8 \text{ [N}\cdot\text{m]}$ $\alpha_3 = Me_3/Me_{3max}$ $= 1.8/7.2$ $= \mathbf{0.250}$	Investigate Me3. Find the load equivalent to impact We. Bumper coefficient $\delta = 4/100$ (urethane bumper) Find the value of Me3max when V = 1.4 and Va = 420mm/s from <Graph 2>.
	$Me_1 = 1/3 \cdot We \cdot L_1$ $= 1/3 \cdot 168 \cdot 0.05$ $= 2.8 \text{ [N}\cdot\text{m]}$ $\alpha_4 = Me_1/Me_{1max}$ $= 2.8/7.2$ $= \mathbf{0.389}$	Investigate Me1. From above, We = 168 Find the value of Me1max when V = 1.4 and Va = 420mm/s from <Graph 2>.

$$\begin{aligned} \Sigma\alpha_n &= \alpha_1 + \alpha_2 + \alpha_3 + \alpha_4 \\ &= 0.111 + 0.031 + 0.250 + 0.389 \\ &= 0.781 \end{aligned}$$

Can be used based on $\Sigma\alpha_n = 0.781 \leq 1$

Series CY1H

Model Selection Method 4

Precautions on Design (2)

Table Deflection

Displacement of table due to pitch moment load
Displacement of Section A when force acts on Section F
 $M_1 = F \times L$

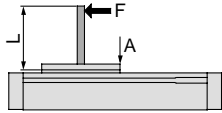

Displacement of table due to roll moment load
Displacement of Section A when force acts on Section F
 $M_2 = F \times L$

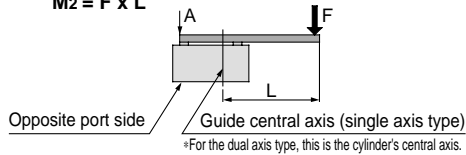

Displacement of table due to yaw moment load
Displacement of Section A when force acts on Section F
 $M_3 = F \times L$

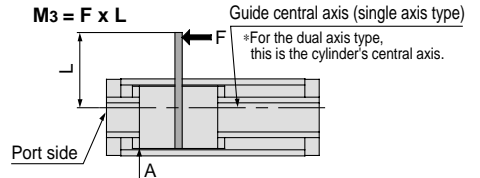

CY1H10

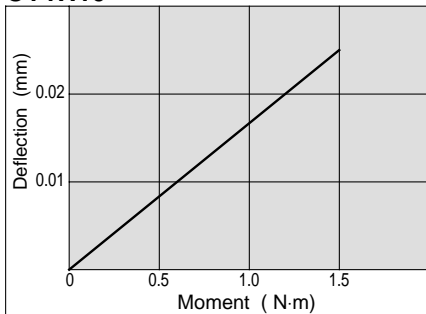

CY1H10

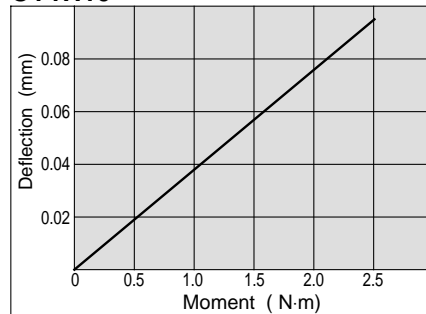

CY1H10

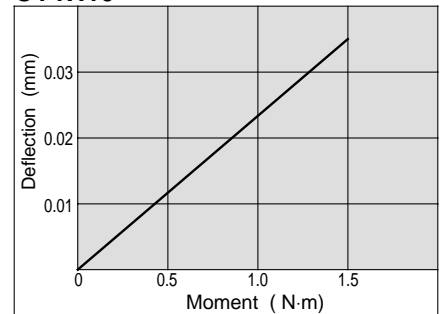

CY1H15, 20, 25

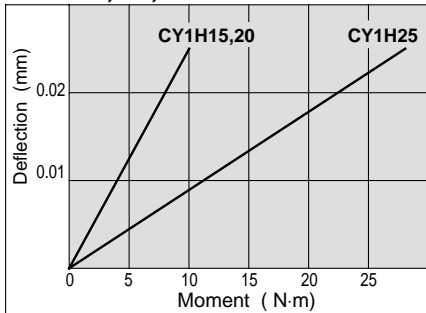

CY1H15, 20, 25

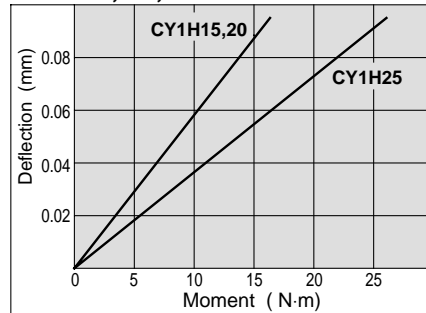

CY1H15, 20, 25

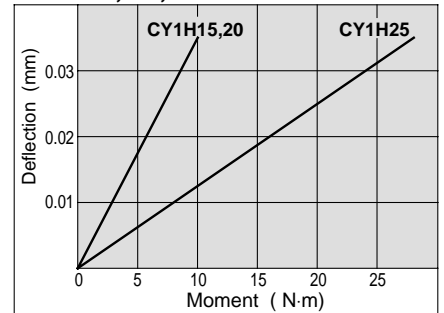

CY1HT25, 32

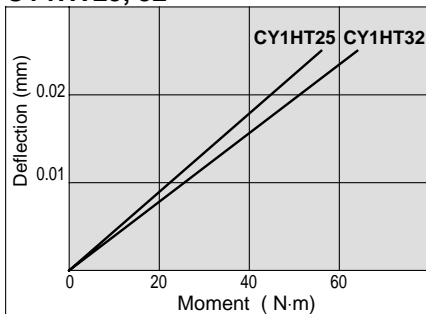

CY1HT25, 32

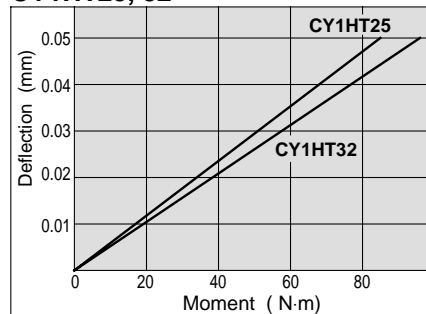

CY1HT25, 32

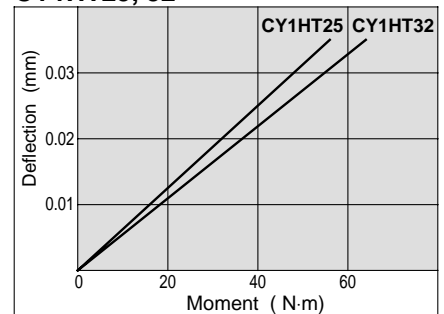

Vertical operation

When using in vertical operation, prevention of work piece dropping due to breaking of the magnetic coupling should be considered. The allowable load weight and maximum operating pressure should be as shown in the table below.

Model	Allowable load weight Wv(kg)	Max. operating pressure Pv(MPa)
CY1H10	2.7	0.55
CY1H15	7.0	0.65
CY1H20	11.0	0.65
CY1H25	18.5	0.65
CY1HT25	18.5	0.65
CY1HT32	30.0	0.65

Intermediate Stops

1) Intermediate stopping of load with an external stopper, etc.

When stopping a load in mid-stroke using an external stopper, etc., operate within the operating pressure limits shown in the table below. The magnetic coupling will break if operated at a pressure exceeding these limits.

Model	Operating pressure limit for intermediate stop Ps (MPa)
CY1H10	0.55
CY1H15	0.65
CY1H20	0.65
CY1H25	0.65
CY1HT25	0.65
CY1HT32	0.65

2) Intermediate stopping of load with an air pressure circuit

When stopping a load using an air pressure circuit, operate at or below the kinetic energy shown in the table below. The magnetic coupling will break if the allowable value is exceeded.

Model	Allowable kinetic energy for intermediate stop Es (J)
CY1H10	0.03
CY1H15	0.13
CY1H20	0.24
CY1H25	0.45
CY1HT25	0.45
CY1HT32	0.88

Construction

Single axis type/CY1H

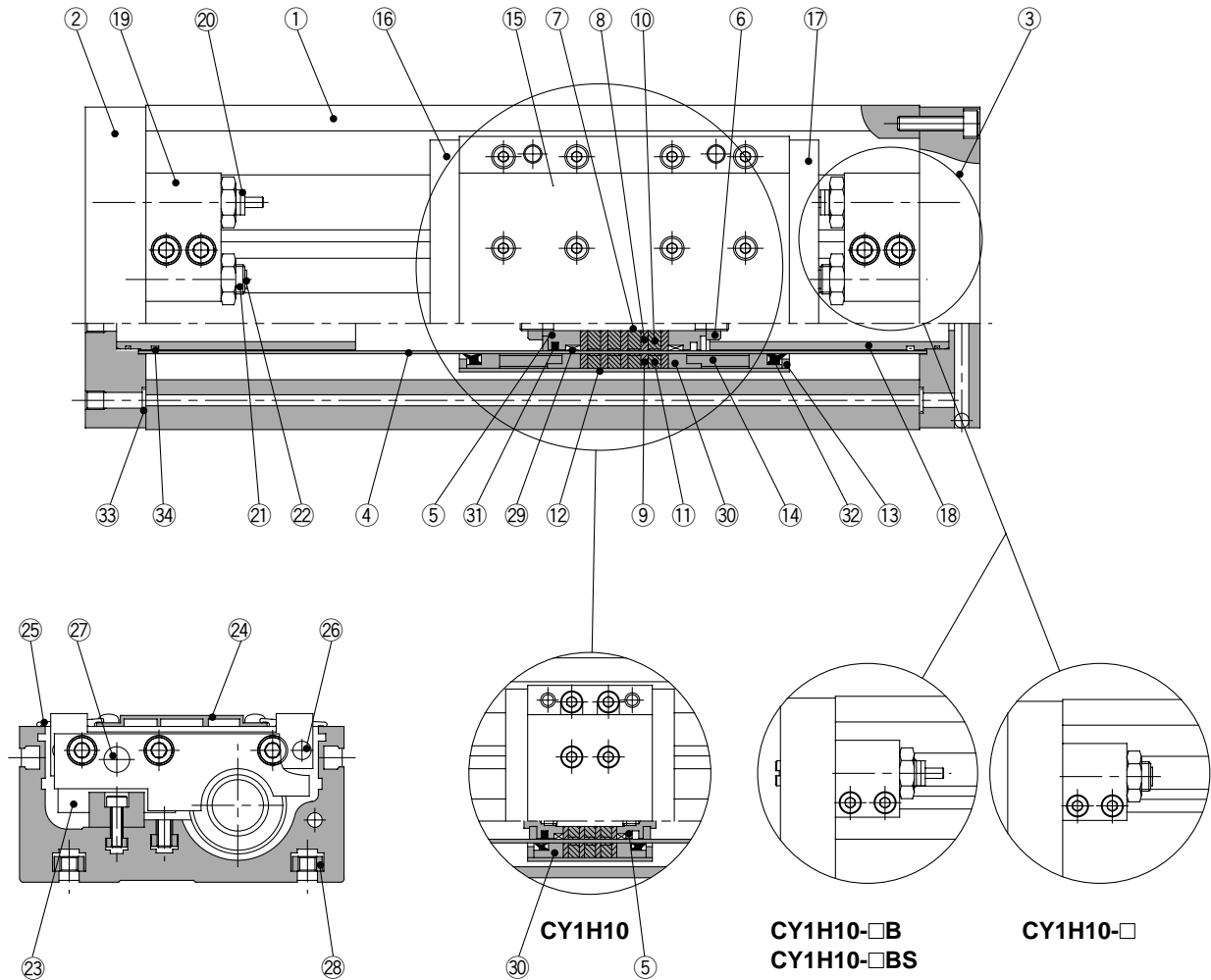

Parts list

No.	Description	Material	Note
1	Body	Aluminum alloy	Hard anodized
2	Plate A	Aluminum alloy	Hard anodized
3	Plate B	Aluminum alloy	Hard anodized
4	Cylinder tube	Stainless steel	
5	Piston	Brass	Kanigen plated (CY1H10,15)
		Aluminum alloy	Chromated (CY1H20, 25)
6	Piston nut	Carbon steel	Zinc chromated (except CY1H10, 15)
7	Shaft	Stainless steel	
8	Piston side yoke	Rolled steel plate	Zinc chromated () for CY1H10
9	External slider side yoke	Rolled steel plate	Zinc chromated () for CY1H10
10	Magnet A	Rare earth magnet	() for CY1H10
11	Magnet B	Rare earth magnet	() for CY1H10
12	External slider tube	Aluminum alloy	
13	Spacer	Rolled steel plate	Nickel plated
14	Space ring	Aluminum alloy	Chromated (except CY1H10)
15	Slide table	Aluminum alloy	Hard anodized
16	Side plate A	Aluminum alloy	Hard anodized
17	Side plate B	Aluminum alloy	Hard anodized

Parts list

No.	Description	Material	Note
18	Internal stopper	Aluminum alloy	Anodized
19	Stopper	Aluminum alloy	Anodized
20	Shock absorber	-	Series RB
21	Adjustment bolt	Chrome molybdenum steel	Nickel plated
22	Adjustment bumper	Urethane rubber	
23	Linear guide	-	
24	Top cover	Aluminum alloy	Hard anodized
25	Dust cover	Special resin	
26	Magnet (for auto switch)	Rare earth magnet	
27	Parallel pin	Carbon steel	Nickel plated
28	Square nut for body mounting	Carbon steel	Nickel plated
* 29	Wear ring A	Special resin	
* 30	Wear ring B	Special resin	() for CY1H10
* 31	Piston seal	NBR	
* 32	Scraper	NBR	
* 33	O-ring	NBR	
* 34	O-ring	NBR	

Replacement parts: Seal kits

Bore size (mm)	Order No.	Content
10	CY1H10-PS	Above Nos. 29, 30, 31, 32, 33, 34
15	CY1H15-PS	
20	CY1H20-PS	
25	CY1H25-PS	

*Seal kits are sets consisting of items 29 through 34, and can be ordered using the order number for each bore size.

Series CY1H

Construction

Dual axis type/CY1HT

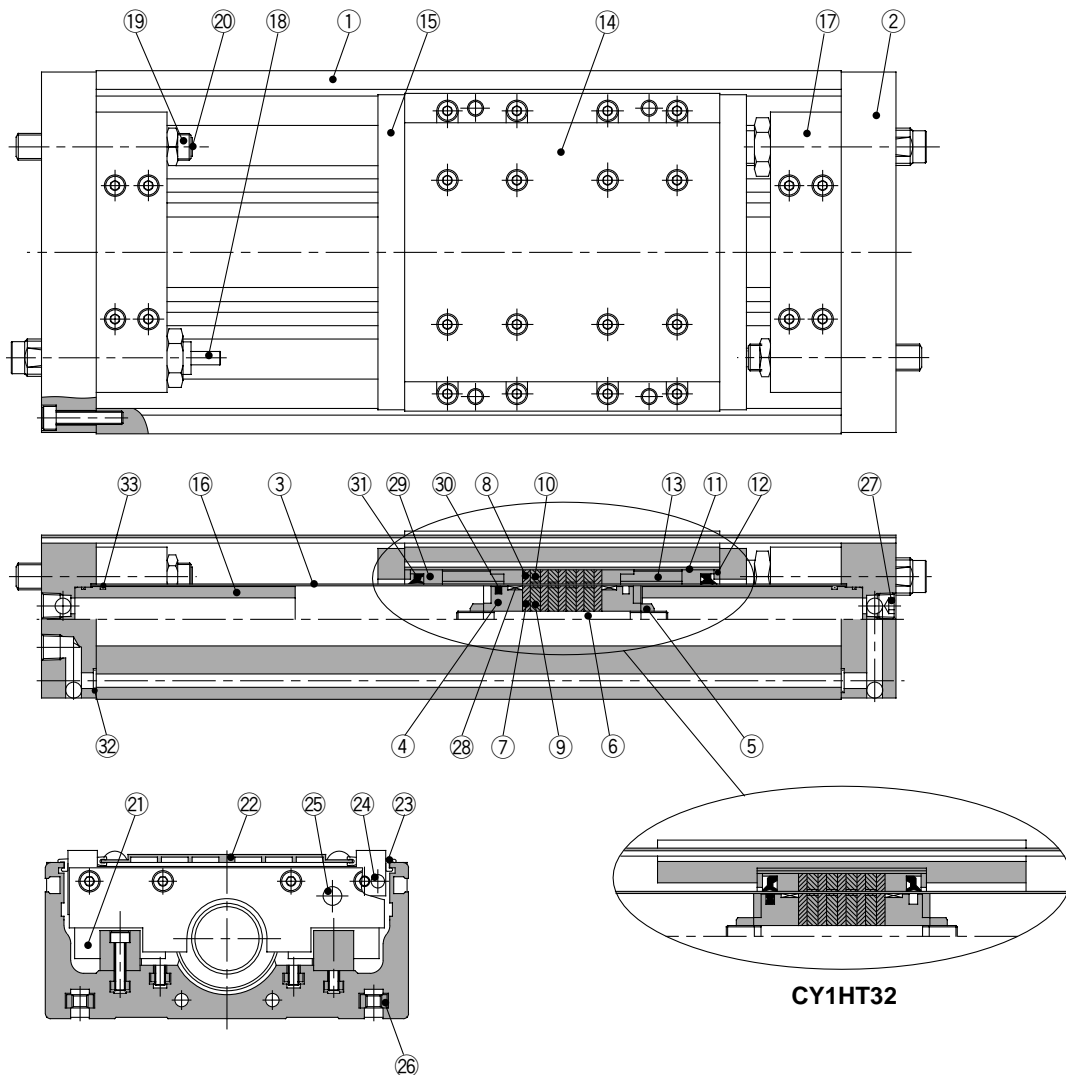

Parts list

No.	Description	Material	Qty.	Note
1	Body	Aluminum alloy	1	Hard anodized
2	Plate	Aluminum alloy	2	Hard anodized
3	Cylinder tube	Stainless steel	1	
4	Piston	Aluminum alloy	2	Chromated
5	Piston nut	Carbon steel	2	Zinc chromated
6	Shaft	Stainless steel	1	
7	Piston side yoke	Rolled steel plate	5	Zinc chromated
8	External slider side yoke	Rolled steel plate	5	Zinc chromated
9	Magnet A	Rare earth magnet	4	
10	Magnet B	Rare earth magnet	4	
11	External slider tube	Aluminum alloy	1	
12	Spacer	Rolled steel plate	2	Nickel plated
13	Space ring	Aluminum alloy	2	Chromated (except CY1HT32)
14	Slide table	Aluminum alloy	1	Hard anodized
15	Side plate	Aluminum alloy	2	Hard anodized (except CY1HT32)
16	Internal stopper	Aluminum alloy	2	Anodized
17	Stopper	Aluminum alloy	2	Anodized

Parts list

No.	Description	Material	Qty.	Note
18	Shock absorber	—	2	Series RB
19	Adjustment bolt	Chrome molybdenum steel	2	Nickel plated
20	Adjustment bumper	Urethane rubber	2	
21	Linear guide	—	2	
22	Top cover	Aluminum alloy	1	Hard anodized
23	Dust cover	Special resin	4	
24	Magnet (for auto switch)	Rare earth magnet	2(4)	() for CY1HT32
25	Parallel pin	Stainless steel	2	
26	Square nut for body mounting	Carbon steel	4	Nickel plated
27	Hexagon socket taper plug	Carbon steel	2	Nickel plated
* 28	Wear ring A	Special resin	2	
* 29	Wear ring B	Special resin	4(2)	() for CY1HT32
* 30	Piston seal	NBR	1	
* 31	Scraper	NBR	2	
* 32	O-ring	NBR	4	
* 33	O-ring	NBR	2	

Replacement parts: Seal kits

Bore size (mm)	Order No.	Content
25	CY1HT25-PS	Above Nos.
32	CY1HT32-PS	28, 29, 30, 31, 32, 33

*Seal kits are sets consisting of items 28 through 33, and can be ordered using the order number for each bore size.

Dimensions

Single axis type/Ø10

CY1H10

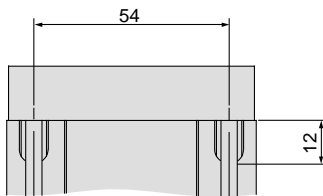
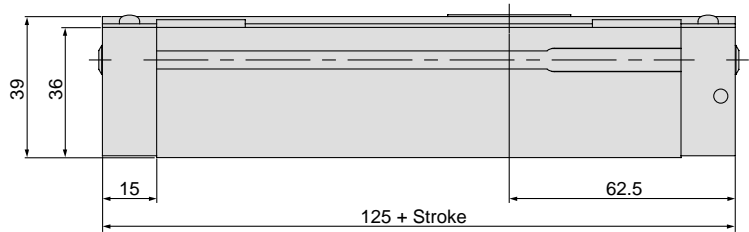
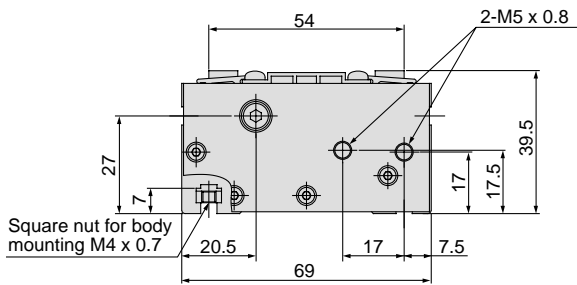
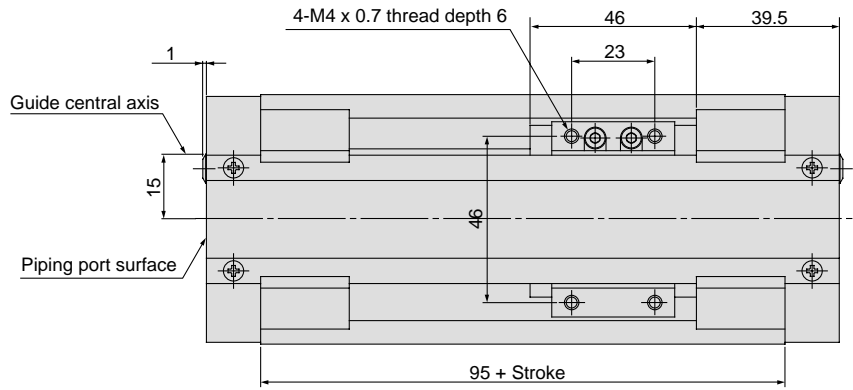
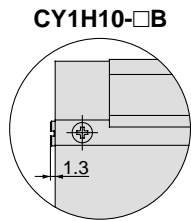

Series CY1H

Dimensions

Single axis type/Ø15, Ø20, Ø25

CY1H15, 20, 25

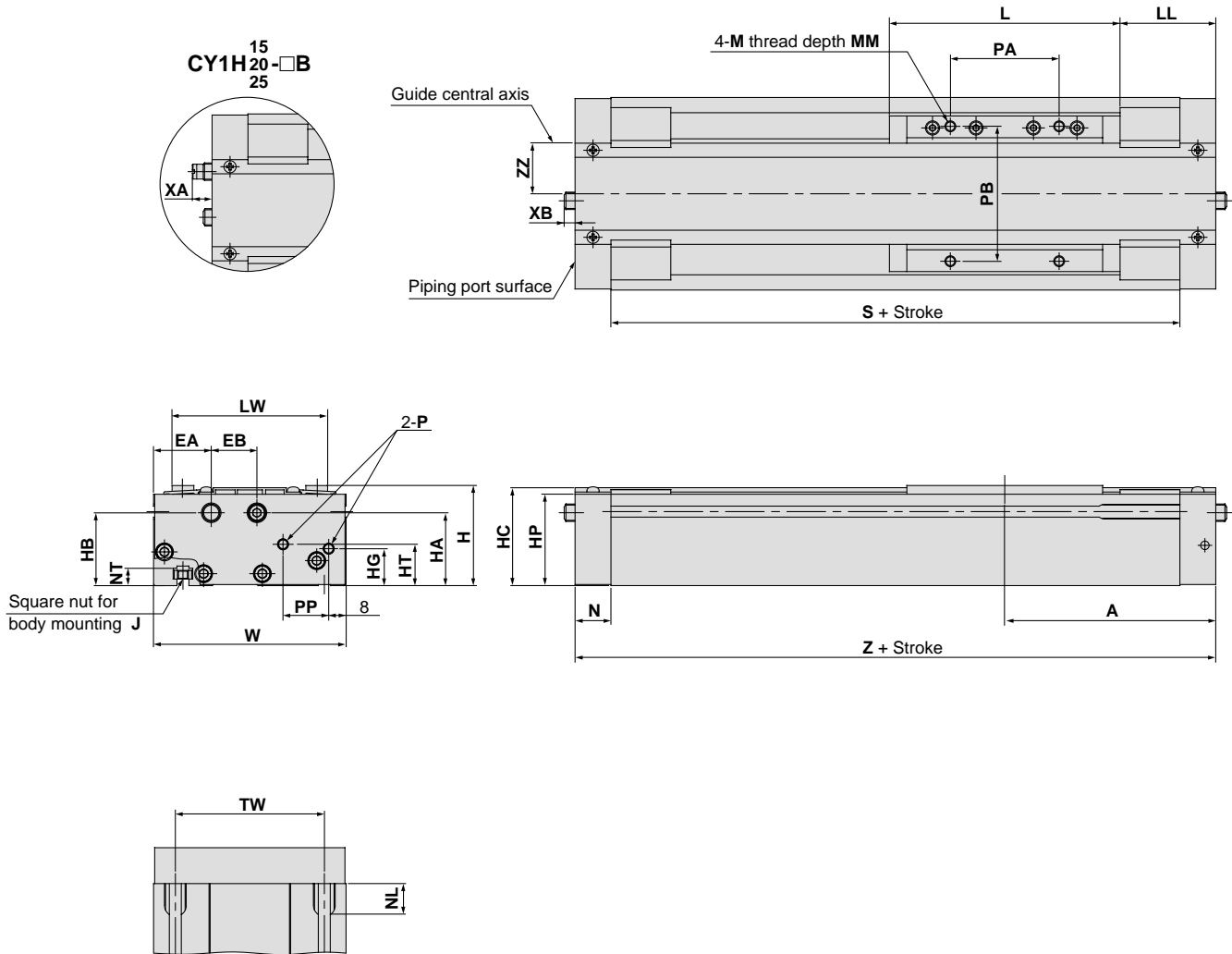

(mm)

Model	A	EA	EB	H	HA	HB	HC	HG	HP	HT	J	L	LL	LW	M	MM	N	NL	NT
CY1H15	97	26.5	21	46	33.5	33.5	45	17	42	19	M5 x 0.8	106	44	71.5	M5 x 0.8	8	16.5	15	8
CY1H20	102.5	26.5	22	54	42.5	41.5	53	16	50	23.5	M5 x 0.8	108	48.5	75.5	M5 x 0.8	8	18	15	8
CY1H25	125	29	24	63	46	46	61.5	25	58.5	28	M6 x 1.0	138	56	86	M6 x 1.0	10	20.5	18	9

Model	P	PA	PB	PP	S	TW	W	XA	XB	Z	ZZ
CY1H15	M5 x 0.8	50	62	21	161	65	88.5	-	-	194	17.5
CY1H20	Rc(PT)1/8	50	65	23	169	70	92.5	-	-	205	19.5
CY1H25	Rc(PT)1/8	65	75	27	209	75	103	11.3	9.5	250	23.5

Dual axis type/ $\varnothing 25$, $\varnothing 32$

CY1HT25, 32

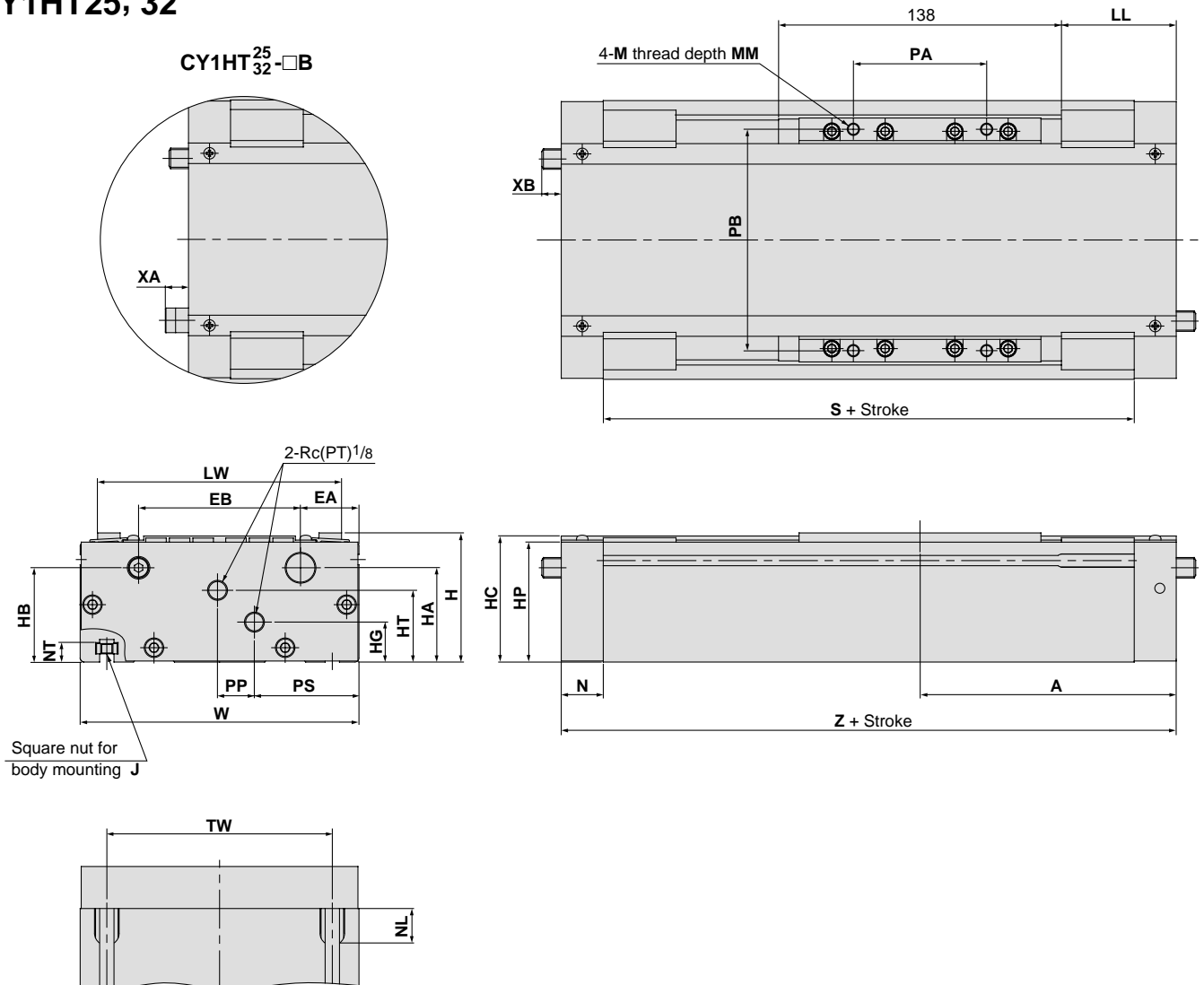

(mm)

Model	A	EA	EB	H	HA	HB	HC	HG	HP	HT	J	LL	LW	M	MM	N	NL	NT	PA
CY1HT25	125	28.5	79	63	46	46	61.5	19.5	58.5	35	M6 x 1.0	56	119	M6 x 1.0	10	20.5	18	9	65
CY1HT32	132.5	30	90	75	52.5	57.5	72.5	25	69.5	43	M8 x 1.25	63.5	130	M8 x 1.25	12	23	22.5	12	66

Model	PB	PP	PS	S	TW	W	XA	XB	Z
CY1HT25	108	18	51	209	110	136	11.3	9.5	250
CY1HT32	115	14	61	219	124	150	9.7	2	265

Series CY1H

Auto Switches/Proper Mounting Position for Stroke End Detection

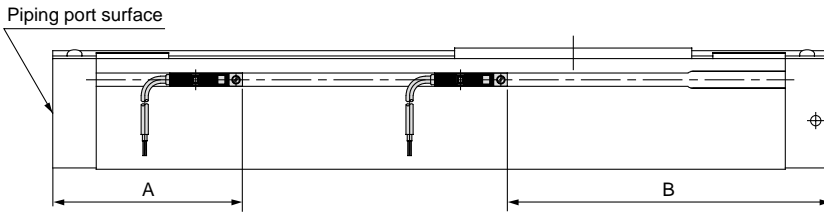

Proper auto switch mounting position

Auto switch model	A			B		
	D-Z7□ D-Z80	D-Y7□W D-Y7□WV	D-Y5□ D-Y6□ D-Y7P D-Y7PV	D-Z7□ D-Z80	D-Y7□W D-Y7□WV	D-Y5□ D-Y6□ D-Y7P D-Y7PV
Cylinder model						
CY1H10	65.5	65.5	65.5	59.5	59.5	59.5
CY1H15	72	72	72	122	122	122
CY1H20	77.5	77.5	77.5	127.5	127.5	127.5
CY1H25	86	86	86	164	164	164
CY1HT25	86	86	86	164	164	164
CY1HT32	82	82	82	183	183	183

Note) 50mm is the minimum stroke available with 2 auto switches mounted.
In case of a stroke less than this, contact SMC.

Auto switch operating range

Auto switch model	D-Z7□ D-Z80	D-Y7□W D-Y7□WV D-Y5□ D-Y6□ D-Y7P D-Y7PV
	Cylinder model	
CY1H10	8	6
CY1H15	6	5
CY1H20	6	5
CY1H25	6	5
CY1HT25	6	5
CY1HT32	9	6

Note) Operating ranges are standards including hysteresis, and are not guaranteed. Large variations may occur depending on the surrounding environment. (variations on the order of ±30%)

Auto Switches Mounting

1N·m: Approx. 10.2kgf·cm

When mounting auto switches, they should be inserted into the cylinder's switch groove from the direction shown in the drawing on the right. After setting in the mounting position, use a flat head watchmakers screw driver to tighten the set screw which is included.

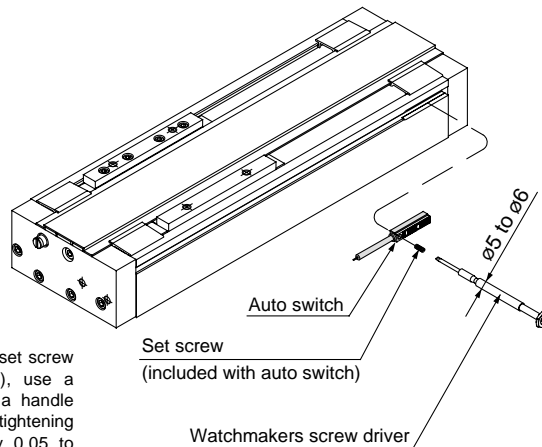

Note) When tightening the auto switch set screw (included with the auto switch), use a watchmakers screw driver with a handle about 5 to 6mm in diameter. The tightening torque should be approximately 0.05 to 0.1N·m (0.51 to 1.02kgf·cm).

Auto Switch Lead Wire Containment Groove

On models CY1H20 and CY1H25 a groove is provided on the side of the body (one side only) to contain auto switch lead wires. This should be used for management of wiring.

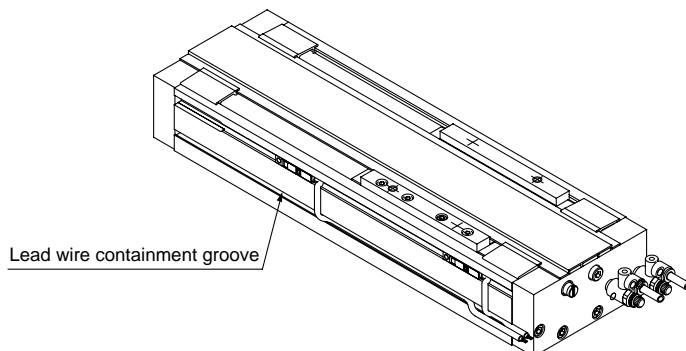

⚠ Specific Product Precautions

Be sure to read before handling. Refer to pages 72 through 75 for safety instructions and actuator precautions.

Mounting

Operation

⚠ Caution

- The interior is protected to a certain extent by the top cover, however, when performing maintenance, etc., take care not to cause scratches or other damage to the cylinder tube, slide table or linear guide by striking them or placing objects on them.

The bore and exterior of tubes are manufactured to precise tolerances, so that even a slight deformation can cause malfunction.

- Since the slide table is supported by precision bearings, strong impacts or large moment, etc. should not be applied when mounting work pieces.

3. Mounting of the cylinder body

The body is mounted using the square nuts, which are included, in the two T-grooves on the bottom of the body. Refer to the table below for mounting bolt dimensions and fastening torque.

Model		CY1H10	CY1H15	CY1H20	CY1H25	CY1HT25	CY1HT32
Bolt dimensions	Screw size	M4 x 0.7	M5 x 0.8		M6 x 1.0		M8 x 1.25
	Dimension t	∠7	∠8	∠8	∠9		∠12
Fastening torque	N·m	1.37	2.65		4.4		13.2
	{kgf·m}	0.14	0.27		0.45		1.35

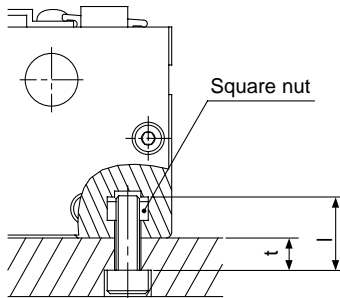

4. Stroke adjustment

Stroke adjustment on one side of 15mm (CY1H10,15, 20) or 30mm (CY1H25, CY1HT25, CY1HT32) can be performed with the adjustment bolt, but when the amount of adjustment exceeds 3mm, the magnetic coupling may be broken depending on the operating conditions. Therefore, operation should confirm to the intermediate stop conditions on page 50. Moreover, the stroke should not be adjusted by moving the stopper, as this can cause damage to the cylinder.

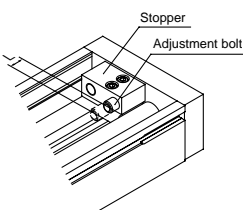

Model	Stroke adjustment range L (mm)
CY1H10, CY1H15, CY1H20	0 to 15
CY1H25, CY1HT25, CY1HT32	0 to 30

⚠ Caution

- The unit can be used with a direct load within the allowable range, but when connecting to a load which has an external guide mechanism, careful alignment is necessary.

Since variation of the shaft center increases as the stroke becomes longer, a connection method should be devised which can assimilate this displacement.

- Since the guide is adjusted at the time of shipment, unintentional movement of the adjustment setting should be avoided.

- This unit can be operated without lubrication. If lubrication is performed, use class 1 turbine oil (without additives) ISO VG32. (Machine oil and spindle oil cannot be used.)

- Contact SMC before operating in an environment where there will be contact with cutting chips, dust (paper scraps, thread scraps, etc.) or cutting oil (gas oil, water, salt water, etc.).

- Do not operate with the magnetic coupling out of position.

In case the magnetic coupling is out of position, push the external slider back into the correct position by hand at the end of the stroke (or correct the piston slider with air pressure).

- Do not disassemble the magnetic components (piston slider, external slider).

This can cause a loss of holding power and malfunction.

Series CY1 Auto Switch Specifications

Auto switch application table

		Cylinder model			
		CY1R	CDY1S	CY1L	CY1H
Reed switches	D-A72, D-A73, D-A80		●	●	
	D-A72H, D-A73H, D-A76H, D-A80H		●	●	
	D-A73C, D-A80C		●	●	
	D-A90, D-A93, D-A96	Note 1)	●	●	
	D-Z73, D-Z76, D-Z80	Note 2)			●
Solid state switches	D-F79, D-F7P, D-J79		●	●	
	D-F7NV, D-F7PV, D-F7BV		●	●	
	D-J79C		●	●	
	D-F79W, D-F7PW, D-J79W		●	●	
	D-F7NWV, D-F7BWV		●	●	
	D-F9N, D-F9P, D-F9B	Note 1)	●		
	D-Y59A, D-Y7P, D-Y59B	Note 2)	●		●
	D-Y69A, D-Y7PV, D-Y69B				●
	D-Y7NW, D-Y7PW, D-Y7BW	Note 2)	●		●
	D-Y7NWV, D-Y7PWV, D-Y7BWV				●
	D-F7BA		●	●	
	D-F7NT		●	●	
	D-F79F		●	●	
	D-F7LF		●	●	

Note 1) Indicates auto switches for CY1R6 to 20.

Note 2) Indicates auto switches for CY1R25 to 63.

Note 3) Refer to "Auto Switch Guide" (E274-A) for detailed specifications (specifications, dimensions, etc.) of switch units.

Series CY1 Auto Switch Specifications 1

Contact Protection Box/CD-P11, CD-P12

1.

<Applicable switches>

D-A7/A8, D-A7□H/A80H, D-A73C, A80C, D-Z7/Z8, D-A9

The above auto switches do not have built-in contact protection circuits.

1. The operating load is an induction load.

2. The length of wiring to the load is 5m or more.

3. The load voltage is 100V or 200VAC.

A contact protection box should be used in any of the above cases, as the life of the contacts may be reduced. (They may stay on continuously.)

Since this effect is especially strong in the case of type D-A72(H), a contact protection box should always be used, regardless of the type of load or length of wiring.

Contact protection box specifications

Part No.	CD-P11		CD-P12
Load voltage	AC100V	AC200V	DC24V
Max. load current	25mA	12.5mA	50mA

*Lead wire length—Switch connection side 0.5m
Load connection side 0.5m



Contact protection box internal circuits

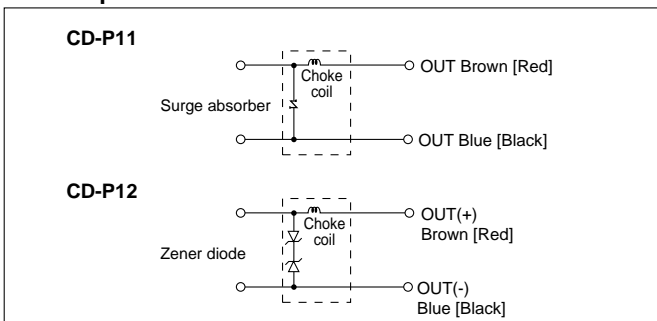

Contact protection box/Dimensions

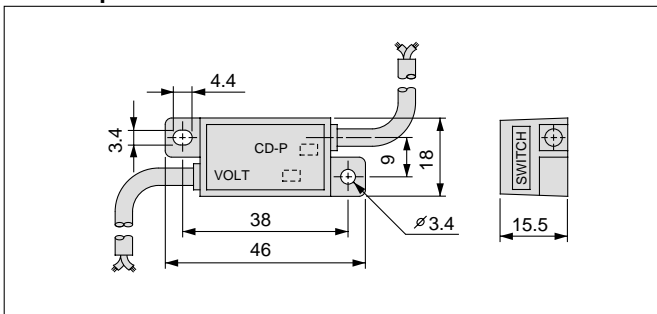

Contact protection box/Connection

To connect a switch unit to a contact protection box, connect the lead wire from the side of the contact protection box marked SWITCH to the lead wire coming out of the switch unit.

Moreover, the switch unit should be kept as close as possible to the contact protection box, with a lead wire length of no more than 1m.

Auto Switch Internal Circuits

Reed switches

D-A72, D-A72H

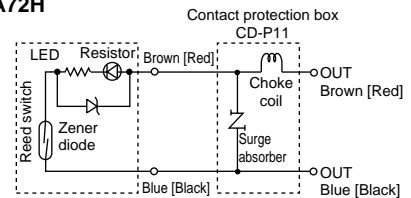

D-A73, D-A73H, D-A93

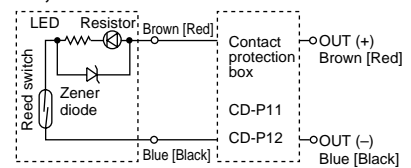

D-A76H, D-A96

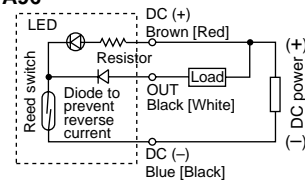

D-A80, D-A80H, D-A90

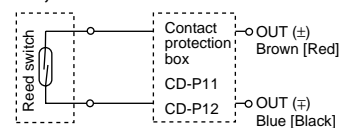

D-A73C

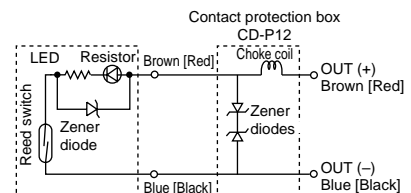

D-A80C

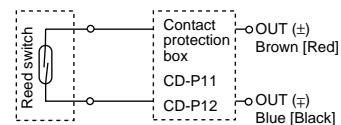

D-Z73

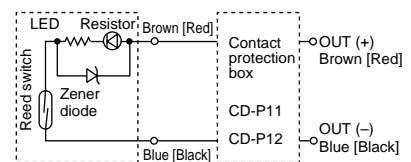

D-Z76

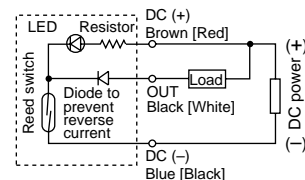

D-Z80

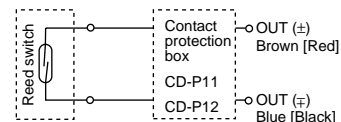

Series CY1 Auto Switch Specifications

Auto Switch Internal Circuits

Solid state switches

D-F79, D-F7NV

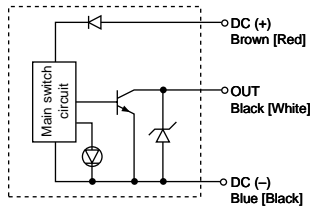

D-F7P, D-F7PV

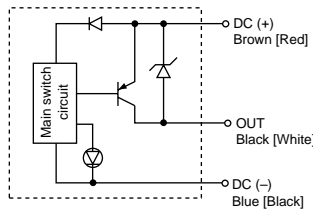

D-J79, D-J79C, D-F7BV

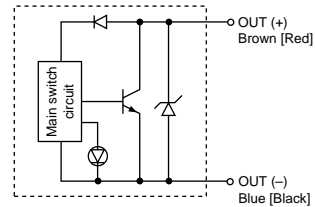

D-F79W

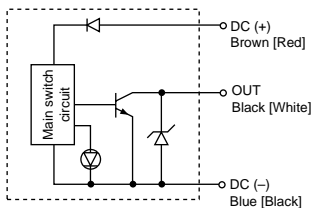

D-F7PW

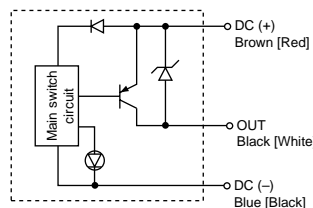

D-J79W

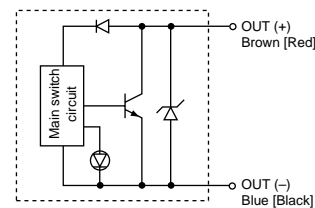

D-F7NT

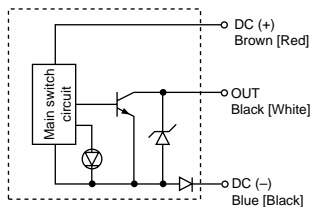

D-F7LF

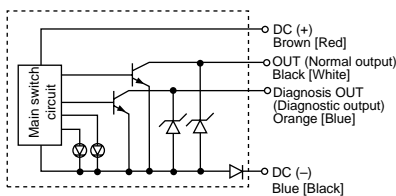

D-F79F

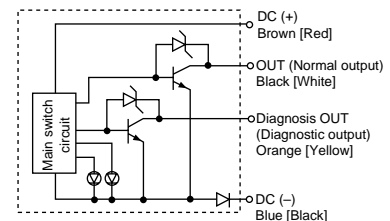

D-F9N

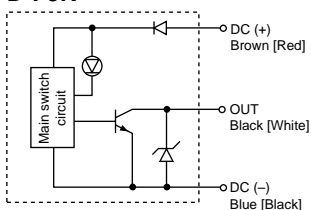

D-F9P

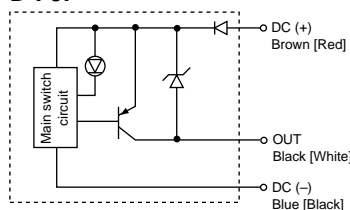

D-F9B

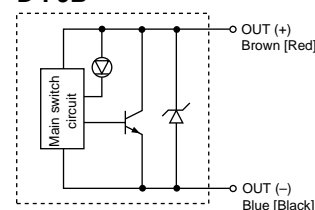

D-Y59A, D-Y69A

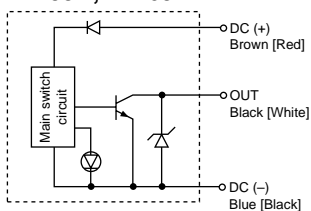

D-Y7P(V)

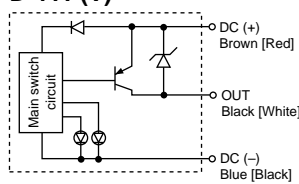

D-Y59B, D-Y69B

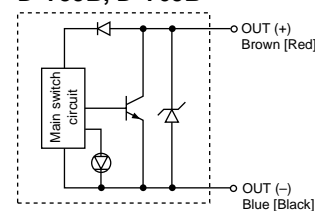

D-Y7NW(V)

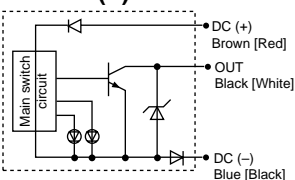

D-Y7PW(V)

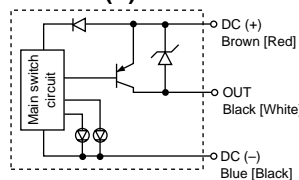

D-Y7BW(V)

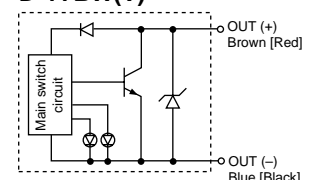

D-F7BA

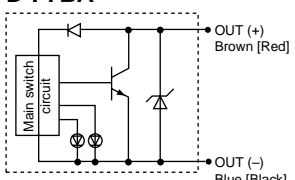

D-F7NWV

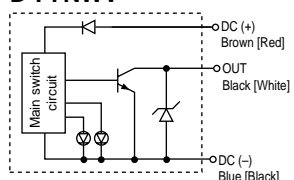

D-F7BWV

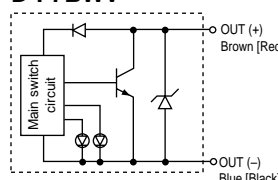

Indicator lights/Method of indication

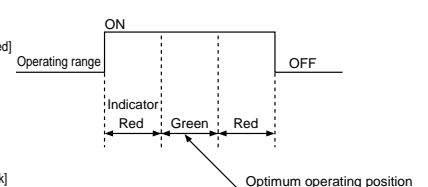

Series CY1 Auto Switches Connections and Examples

Basic Wiring

Solid state 3 wire, NPN

(Power supply for switch and load are the same.)

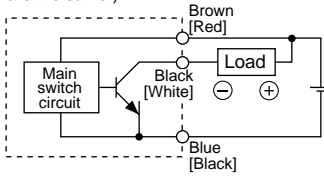

(Power supply for switch and load are separate.)

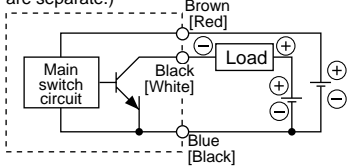

Solid state 3 wire, PNP

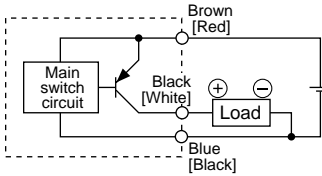

2 wire <Solid state>

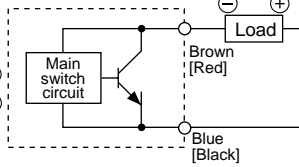

2 wire <Reed switch>

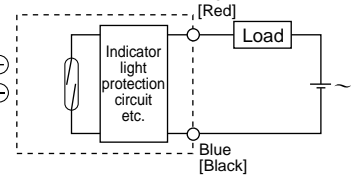

Examples of Connection to PLC (Sequence Controller)

Specification for sink input

3 wire, NPN

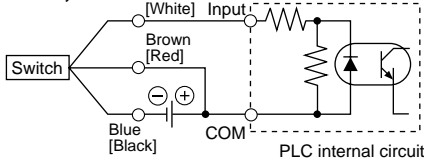

2 wire

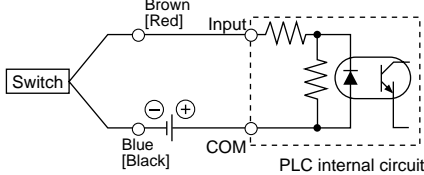

Specification for source input

3 wire, PNP

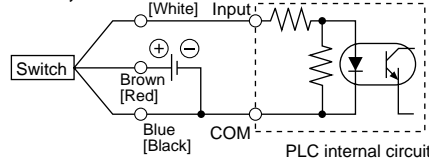

2 wire

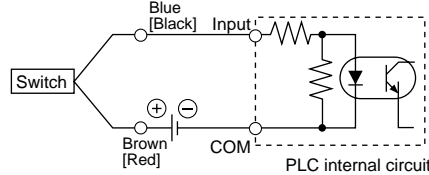

Connect according to the applicable PLC input specifications, as the connection method will vary depending on the PLC input specifications.

Connection Examples for AND (Series) and OR (Parallel)

3 wire

AND connection for NPN output (Using relays)

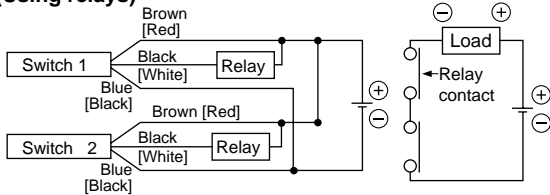

AND connection for NPN output (Performed with switches only)

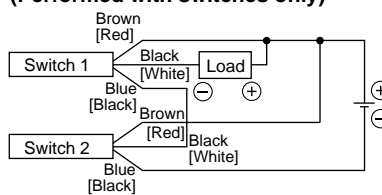

OR connection for NPN output

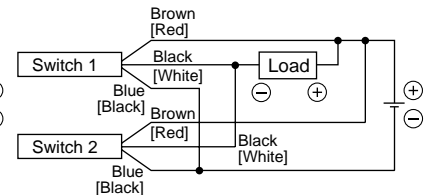

The indicator lights will light up when both switches are turned ON.

2 wire with 2 switch AND connection

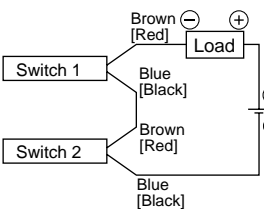

When two switches are connected in series, a load may malfunction because the load voltage will decline when in the ON state. The indicator lights will light up if both of the switches are in the ON state.

$$\begin{aligned} \text{Load voltage at ON} &= \text{Power supply voltage} - \text{Residual voltage} \times 2 \text{ pcs.} \\ &= 24\text{V} - 4\text{V} \times 2 \text{ pcs.} \\ &= 16\text{V} \end{aligned}$$

Example: Power supply is 24VDC
Voltage decline in switch is 2V

2 wire with 2 switch OR connection

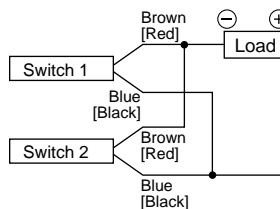

<Solid state>
When two switches are connected in parallel, malfunction may occur because the load voltage will increase when in the OFF state.

<Reed switch>
Because there is no current leakage, the load voltage will not increase when turned OFF, but due to the number of switches in the ON state, the indicator lights will sometimes get dark or not light up, because of dispersion and reduction of the current flowing to the switches.

$$\begin{aligned} \text{Load voltage at OFF} &= \text{leakage current} \times 2 \text{ pcs.} \times \text{load impedance} \\ &= 1\text{mA} \times 2 \text{ pcs.} \times 3\text{k}\Omega \\ &= 6\text{V} \end{aligned}$$

Example: Load impedance is 3kΩ
Leakage current from switch is 1mA

Series CY1 Auto Switches Specifications

⚠ Specific Product Precautions

Before handling auto switches, be sure to read "Auto Switch Precautions" on pages 76 to 78.

Auto Switch Common Specifications

Type	Reed switch	Solid state switch
Leakage current	None	3 wire: 10μA or less 2 wire: 1mA or less
Actuation time	1.2ms	1ms or less ^{Note2)}
Impact resistance	300m/s ² {30.6G}	1000m/s ² {102G}
Insulation resistance	50MΩ or more with a 500VDC megohmmeter (between lead wire & case)	
Withstand voltage	1500VAC for 1 minute ^{Note 1)} (between lead wire & case)	1000VAC for 1 minute (between lead wire & case)
Ambient temperature	-10 to 60°C	

Note 1) Electrical entry: Connector type (A73C, A80C, C73C) and A9 are 1000VAC for 1 minute (between lead wire and case).

Note 2) Except for solid state auto switch with timer (F7NTL).

Lead Wire length

Lead wire length indication (Example)

D-A73 **L**

• Lead wire length

Nil	0.5m
L	3m
Z	5m
*N	None

*Applicable only to connector type switch D-□□C.

Note 1) Lead wire length Z: 5m applicable auto switches

Reed switch: D-A73(C)(H)/A80C, D-Z73

Solid state switch: All models are produced upon receipt of order (standard procedure). Except for D-F9/F7□WV.

Note 2) The standard lead wire length is 3m for solid state switches with timer and water resistant solid state switches with 2 color indication. (0.5m length is not available.)

Note 3) The standard lead wire lengths are 3m and 5m for strong magnetic field resistant 2 color indicator type solid state switches. (0.5m length is not available.)

Part Nos. for lead wires with connector (applicable only to connector type switches)

Model	Lead wire length
D-LC05	0.5m
D-LC30	3m
D-LC50	5m

Auto Switch Hysteresis

The distance from the position at which movement of the external slider turns on an auto switch, to the point at which reverse movement turns off the switch is called hysteresis. This hysteresis is included in part (one side) of the operating range.

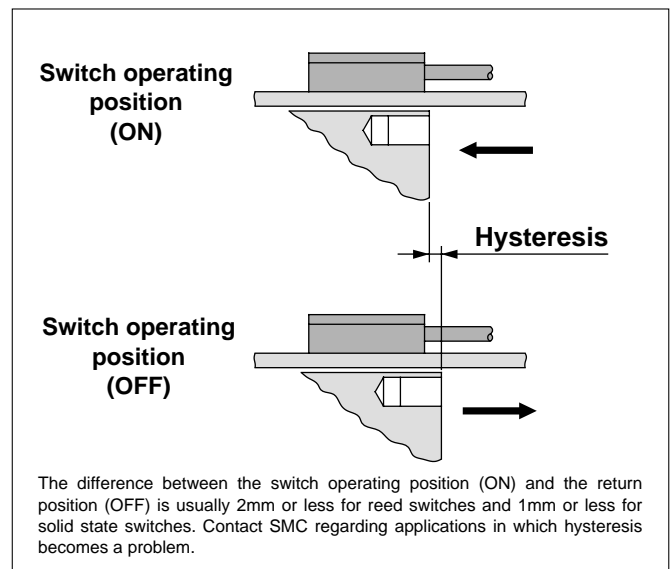

The difference between the switch operating position (ON) and the return position (OFF) is usually 2mm or less for reed switches and 1mm or less for solid state switches. Contact SMC regarding applications in which hysteresis becomes a problem.

Recommended Relays

Fuji Electric Co., Ltd.	HH5
OMRON Corporation	MY
Matsushita Electric Works, Ltd.	HC
IDEC IZUMI CORPORATION	RM
Mitsubishi Electric Corporation	RD

Series CY1

Individual Order Made Specifications 1

Contact SMC for detailed specifications, lead times and prices, etc.

Order made product application table

Specifications	Model	Bore size (mm)								
		6	10	15	20	25	32	40	50	63
1 XB6 (Heat resistant specifications) P.66	CY1B	●	●	●	●	●	●	●	●	●
	CY1B			●	●	●	●	●	●	●
(Note 2) 2 XB9 (Low speed specifications) P.66	CY1R			○	○	○	○	○	○	○
	CY1S			●	●	●	●	●	●	●
	CY1L			●	●	●	●	●	●	●
	CY1H			○	○	○	○	○	○	○
	CY1B			●	●	●	●	●	●	●
3 XB11 (Long stroke) P.66	CY1B	●	●	●	●	●	●	●	●	●
	CY1R	○	○	○	○	○	○	○	○	○
	CY1S	●	●	●	●	●	●	●	●	●
	CY1L	●	●	●	●	●	●	●	●	●
	CY1H		○	○	○	○	○	○	○	○
4 XB13 (Very low speed specifications) P.66	CY1B	●	●	●	●	●	●	●	●	●
	CY1R	○	○	○	○	○	○	○	○	○
	CY1S	●	●	●	●	●	●	●	●	●
	CY1L	●	●	●	●	●	●	●	●	●
	CY1H		○	○	○	○	○	○	○	○
5 XC18 (NPT port specifications) P.66	CY1B			●	●	●	●	●	●	●
	CY1R			○	○	○	○	○	○	○
	CY1S			●	●	●	●	●	●	●
	CY1L			○	○	○	○	○	○	○
	CY1H			○	○	○	○	○	○	○
6 XC24 (With magnetic shield) P.66	CY1B	●	●	●	●	●	●	●	●	●
	CY1B	●	●	●	●	●	●	●	●	●
7 XC57 (With floating joint) P.67, 68	CY1R	●	●	●	●	●	●	●	●	●
	CY1B			●	●	●	●	●	●	●
	CY1R			○	○	○	○	○	○	○
8 X116 (Air-hydro specifications) P.69	CY1S			●	●	●	●	●	●	●
	CY1L			●	●	●	●	●	●	●
	CY1H			○	○	○	○	○	○	○
	CY1B			○	○	○	○	○	○	○

Note 1) The applicable series and bore sizes of products with the ● symbol. Contact SMC regarding products with the ○ symbol.

Note 2) ø6 and ø10 are standard products which can be used at low speed.

Series CY1

Individual Order Made Specifications 2

Contact SMC for detailed specifications, lead times and prices, etc.

Order made product application table

Specifications	Model	Bore size (mm)								
		6	10	15	20	25	32	40	50	63
9 X132 (Axial ports) P.69	CY1B	●	●	●	●	●	●	●	●	●
10 X160 (High speed specifications) P.69	CY1B				●	●	●	●	●	●
	CY1R				○	○	○	○	○	○
11 X168 (Helical insert screw specifications) P.69	CY1B				●	●	●	●	●	●
	CY1R				●	●	●	●	●	●
	CY1S				●	●	●	●	●	●
	CY1L				●	●	●	●	●	●
12 X206 (Body mounting surface, 2 sides) P.70	CY1B				●	●	●	●	●	●
	CY1S				●	●	●	●	●	●
13 X210 (Oil-free exterior specifications) P.70	CY1B				●	●	●	●	●	●
	CY1S				●	●	●	●	●	●
14 X211 (CY□ dimension specifications) P.70	CY1B				●	●	●	●	●	●
	CY1S				●	●	●	●	●	●
15 X322 (Outside of cylinder tube with hard chrome plating) P.71	CY1B				●	●	●	●	●	●
	CY1R				○	○	○	○	○	○
	CY1S				●	●	●	●	●	●
	CY1L				○	○	○	○	○	○
16 X324 (With felt, oil-free exterior specifications) P.71	CY1B				●	●	●	●	●	●
	CY1S				●	●	●	●	●	●
17 X431 (With 2 switch rails) P.71	CY1S				●	●	●	●	●	●
	CY1L				○	○	○	○	○	○

Note 1) The applicable series and bore sizes of the products with the ● symbol. Contact SMC regarding products with the ○ symbol.

Series CY1

Order Made Specifications 1

Contact SMC for detailed specifications, lead times and prices, etc.

1 Heat resistant (-10 to 150°C) specifications -XB6

CY1B Bore H - Stroke -XB6
Heat resistant specifications

1. Basic specifications

Applicable series	CY1B			
Bore size	ø6 to ø63			
Ambient temperature	-10°C to 80°C	Over 80°C to 110°C	Over 110°C to 150°C	
Max. operating pressure (MPa)	0.7	0.6	0.5	
Magnet holding force (N) *	ø6	19.8	17.2	14.4
	ø10	55.7	47.9	40.0
	ø15	125.4	107.7	90.1
	ø20	222.9	191.5	160.1
	ø25	348.3	299.3	250.2
	ø32	570.7	490.3	410.0
	ø40	891.8	766.2	640.6
	ø50	1393.4	1197.1	1000.9
	ø63	2212.1	1900.6	1589.0

*) Use caution, as once an initial setting is made in a high temperature range, the cylinder's holding force will remain at the initial value even if the ambient temperature is reduced.

Since there are no bumpers, an external shock absorber should be installed.

2. Maximum operating pressure for intermediate stop & vertical operation

Ambient temperature	80°C or less	Over 80°C to 110°C	Over 110°C to 150°C
Max. operating pressure (MPa)	0.6	0.5	0.4

2 Low speed (15 to 50mm/s) specifications -XB9

CY1B Bore Magnetic holding force Stroke -XB9
CY1S
CY1L
Low speed (15 to 50mm/s) rodless cylinder

Even at a low drive speed of 15 to 50mm/s there is no sticking and slipping. Furthermore, there is no lurching at start up, allowing smooth low speed drive through the entire stroke.

Specifications

Applicable series	CY1B/CY1S/CY1L
Bore size	CY1B: ø15 to ø63/CY1S, CY1L: ø15 to ø40
Max. operating pressure	0.7MPa{7.1kgf/cm ² }
Min. operating pressure	0.18MPa{1.8kgf/cm ² }
Piston speed	15 to 50mm/s

Note 1) Use caution with the slider type, as the piston speed may vary depending on the load conditions.

Note 2) ø6 and ø10 are standard products which can be used at low speed.

3 Long stroke (2001mm and up) -XB11

CY1B Bore Magnetic holding force Stroke -XB11
Long stroke (2001mm and up)

When the stroke exceeds 2000mm (2001mm and up)

Specifications

Applicable series	CY1B
Bore size	ø20 to ø63
Applicable stroke	2001st and up

4 Very low speed (7 to 50mm/s) specifications -XB13

CY1B Bore Magnetic holding force Stroke -XB13
CY1S
CY1L
Very low speed (7 to 50mm/s) specifications

There is no sticking and slipping even at very low drive speeds of 7 to 50mm/s. Furthermore, there is no lurching at start up, allowing smooth drive through the entire stroke.

Specifications

Applicable series	CY1B/CY1S/CY1L
Bore size	CY1B: ø6 to ø63/CY1S, CY1L: ø6 to ø40
Max. operating pressure	0.7MPa{7.1kgf/cm ² }
Min. operating pressure	0.18MPa{1.8kgf/cm ² }
Piston speed	7 to 50mm/s

5 NPT piping port specifications -XC18

CY1B Bore Magnetic holding force Stroke -XC18
CY1S
NPT piping port specifications

Specifications

Applicable series	CY1B/CY1S
Port size	CY1B: ø20 to ø63/CY1S: ø20 to ø40

6 With magnetic shielding plate -XC24

CY1B Bore Magnetic holding force Stroke -XC24
With magnetic shielding plate

Shields against leakage of magnetic flux from the external slider.

Specifications

Applicable series	CY1B
Bore size	ø6 to ø63

Dimensions

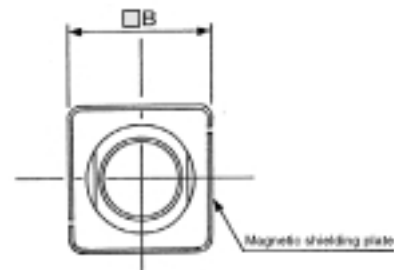

Bore size (mm)	6	10	15	20	25	32	40	50	63
□B	19	27	37	38	48	62	72	88	102
Standard dimension (□B)	17	25	35	36	46	60	70	86	100

*Dimensions other than those in the table above are the same as the basic type. Refer to page 7.

Series CY1

Order Made Specifications 2

Contact SMC for detailed specifications, lead times and prices, etc.

7 Rodless cylinder with floating joint (CY1B)

Symbol

-XC57

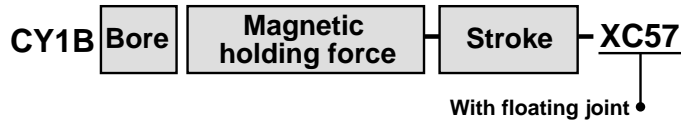

A special floating joint is added to the Series CY1B, and the number of connections to the guide on the other axis (the load side) is reduced. The attachment of the bolt to the floating joint and the load is not limited to the top or bottom. ($\phi 6$, $\phi 10$ are attached from the top.)

Specifications

Fluid	Air
Cylinder bore size	$\phi 6$, $\phi 10$, $\phi 15$, $\phi 20$, $\phi 25$, $\phi 32$, $\phi 40$, $\phi 50$, $\phi 63$
Max. operating pressure	0.7MPa{7.1kgf/cm ² }
Min. operating pressure	0.18MPa{1.8kgf/cm ² }
Piston speed	50 to 400mm/s
Mounting orientation	Unrestricted
Auto switch	Not mountable

Note) Since the body of this cylinder is designed for connection with a floating joint, and cannot be connected to the bodies of standard products, contact SMC if necessary.

Construction/Dimensions

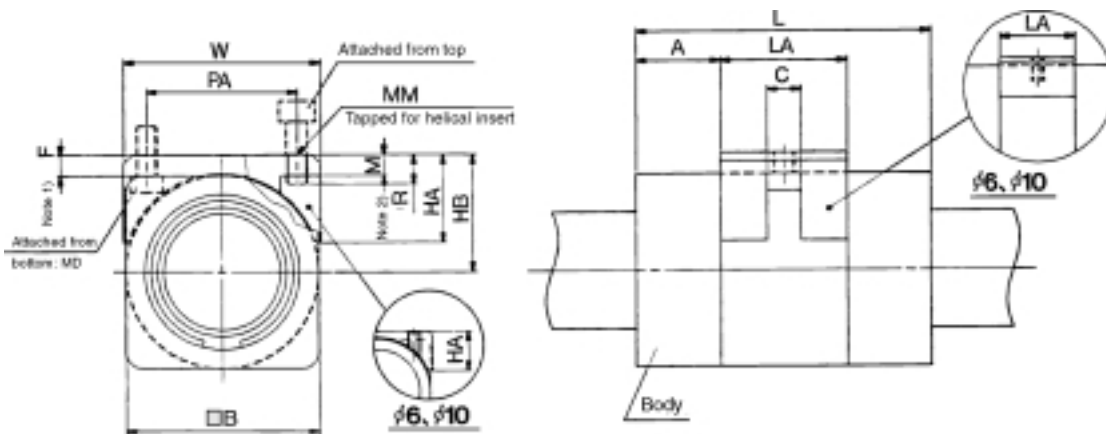

Model	A	$\square B$	C	F ^{Note 1)}	HA	HB	L	LA	MM	MD	M	PA	R ^{Note 2)}	W
CY1B 6	10	17	—	2.5	6.3	11	35	15	M3 x 0.5 x 3/	—	—	12	—	18
CY1B10	10	25	—	2.5	9.5	15	38	18	M3 x 0.5 x 3/	—	—	17	—	26
CY1B15	16	35	6.5	5.5	16.5	23	57	25	M4 x 0.7	M3	4	25	6	36
CY1B20	18	36	6.5	5.5	17	23.5	66	30	M4 x 0.7	M3	4	27	6	37
CY1B25	20	46	8.0	5.5	21	28.5	70	30	M5 x 0.8	M4	5	36	7	47
CY1B32	22.5	60	9.5	6.0	27.5	36	80	35	M6 x 1.0	M5	6	47	8	61
CY1B40	26	70	9.5	6.0	28.5	41	92	40	M6 x 1.0	M5	6	55	8	71
CY1B50	35	86	11	6.0	35	49	110	40	M8 x 1.25	M6	8	65	11	87
CY1B63	36	100	18	7.0	42	57	122	50	M8 x 1.25	M6	10	80	11	101

Note 1) Dimension F provides a clearance of 1mm between the body and the floating joint, but does not consider dead weight deflection of the cylinder tube, etc. When put into operation, an appropriate value should be set which considers dead weight deflection and alignment variations with respect to the other axis. (Refer to the dead weight deflection table on page 5.)

Note 2) Use caution when attached from the top and operated at or above dimension R (3mm or more for $\phi 6$, $\phi 10$), because the end of the screw will contact the body, and floating cannot be maintained in some cases.

Series CY1

Order Made Specifications 3

Contact SMC for detailed specifications, lead times and prices, etc.

Symbol

7 Rodless cylinder with floating joint (CY1R)

-XC57

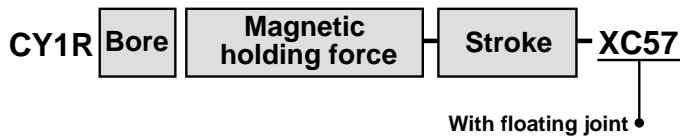

A special floating joint is added to the Series CY1R, and the number of connections to the guide on the other axis (the load side) is reduced. The attachment of the bolt to the floating joint and the load is not limited to the top or bottom.

Specifications

Fluid	Air
Cylinder bore size	ø6, ø10, ø15, ø20, ø25, ø32, ø40, ø50, ø63
Max. operating pressure	0.7MPa{7.1kgf/cm ² }
Min. operating pressure	0.18MPa{1.8kgf/cm ² }
Piston speed	50 to 500mm/s
Mounting	Direct mount type
Auto switch	Mountable

Note) Since the body of this cylinder is designed for connection with a floating joint, and cannot be connected to the bodies of standard products, contact SMC if necessary.

Construction/Dimensions

ø6, ø10, ø15

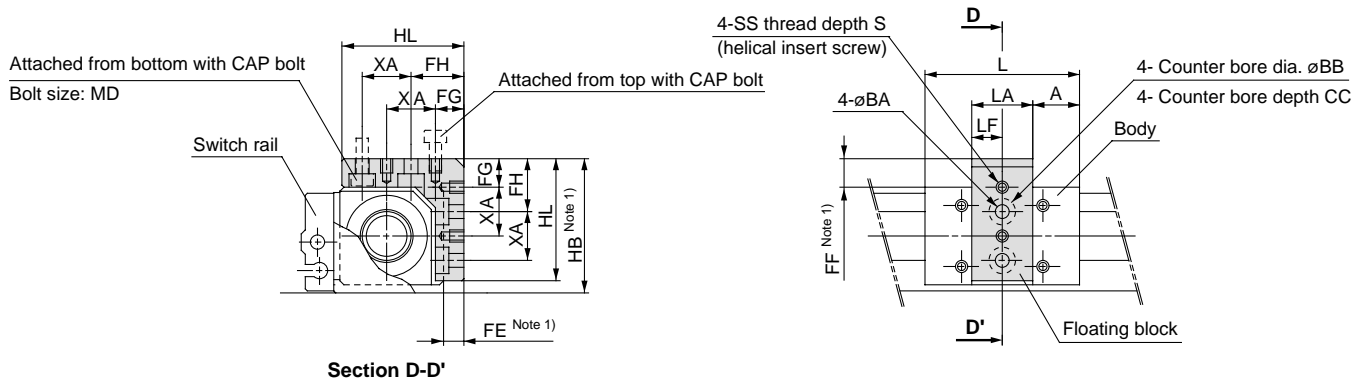

ø20, ø25, ø32, ø40, ø50, ø63

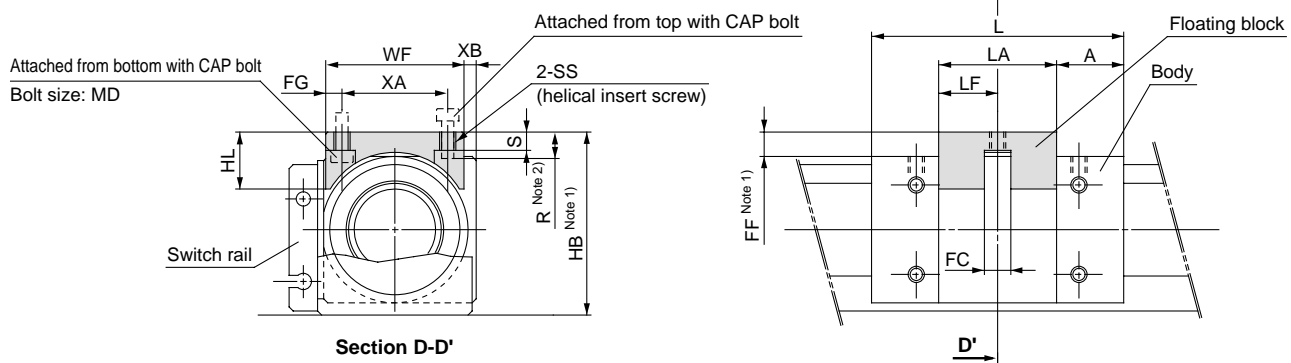

(mm)

Model	A	BA	BB	CC	FC	FE (Note 1)	FF (Note 1)	FG	FH	HB (Note 1)	HL	L	LA	LF	MD	R (Note 1)	S	SS	WF	XA	XB
CY1R6	9.5	3.4	6.5	3.3	-	5	7	5.5	10.5	26	23	34	15	7.5	M3	-	3.5	M3 x 0.5	-	10	-
CY1R□10	11.5	3.4	6.5	3.3	-	5	7	7	13	33	30	38	15	7.5	M3	-	3.5	M3 x 0.5	-	12	-
CY1R□15	18	4.5	8	4.4	-	4.5	6.5	7.5	14.5	38.5	35.5	53	17	8.5	M4	-	4.5	M4 x 0.7	-	14	-
CY1R□20	16.5	-	-	-	6.5	-	6	4	-	45	14	62	29	14.5	M3	7	4.5	M4 x 0.7	34	26	3
CY1R□25	20.5	-	-	-	8	-	7	4	-	51	17	70	29	14.5	M4	8	5.5	M5 x 0.8	39	31	3
CY1R□32	21	-	-	-	9.5	-	7.5	4.5	-	62.5	22	76	34	17	M5	10	6.5	M6 x 1	50	41	3
CY1R□40	25.5	-	-	-	9.5	-	7.5	7.5	-	74.5	28	90	39	19.5	M5	10	6.5	M6 x 1	60	45	3
CY1R□50	35.5	-	-	-	11	-	7.5	9	-	92.5	38	110	39	19.5	M6	15	10	M8 x 1.25	78	60	3
CY1R□63	34.5	-	-	-	18	-	7.5	10	-	104.5	39	118	49	24.5	M6	15	10	M8 x 1.25	90	70	3

Note 1) FE, FF and HB provide a clearance of 1mm between the body and the floating joint, but do not consider dead weight deflection of the cylinder tube, etc. When put into operation, an appropriate value should be set which considers dead weight deflection and alignment variations with respect to the other axis. (Refer to the dead weight deflection table on page 14.)

Note 2) Use caution when attached from the top and operated at or above dimension R, because the end of the screw will contact the body, and floating cannot be maintained in some cases.

Series CY1

Order Made Specifications 4

Contact SMC for detailed specifications, lead times and prices, etc.

8 Hydro specification rodless cylinder -X116

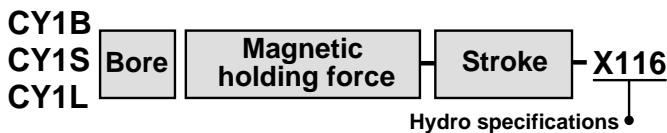

Suitable for precision low speed feeding, intermediate stopping and skip feeding of the cylinder.

Specifications

Applicable series	CY1B/CY1S/CY1L
Bore size	CY1B: $\phi 25$ to $\phi 63$ CY1S/CY1L: $\phi 25$ to $\phi 40$
Fluid	Turbine oil
Piston speed	15 to 300mm/s

Note 1) Piping is possible from the plates on both sides (double side piping).
Note 2) When performing intermediate stops with an air-hydro circuit, set the kinetic energy of the load so that it does not exceed the allowable value. (Regarding the allowable value, refer to the section "Intermediate stops" for each series.)

Dimensions (Port positions are modified on CY1S and CY1L.)

Model	Aperture dia.
CY1B25	6
CY1B32	7.5
CY1B40	8.5
CY1B50	9
CY1B63	9

* CY1B dimensions are the same as the standard type.

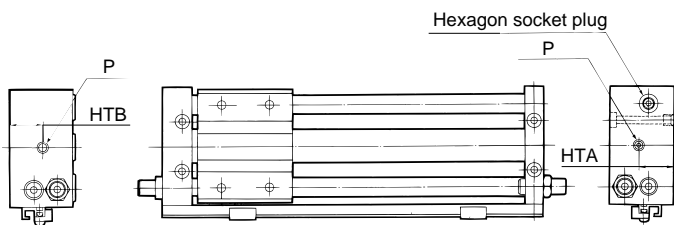

Model	HTA	HTB	P	Aperture dia.
CY1S25	20	20	Rc(PT)1/8	7.5
CY1L25	20	23		8.2
CY1S32	24	24	Rc(PT)1/8	7.5
CY1L32	25	26.5		8.2
CY1S40	25	25	Rc(PT)1/4	8
CY1L40	30	30.5		11

* Dimensions other than the above are the same as the standard type.

9 Modified to axial air supply port -X132

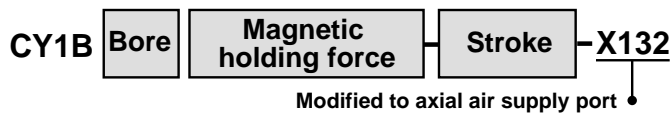

The air supply port has been changed to an axial position on the head cover.

Specifications

Applicable series	CY1B
Bore size	$\phi 6$ to $\phi 63$

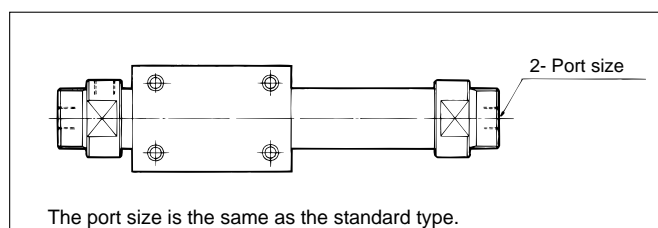

10 High speed specification rodless cylinder -X160

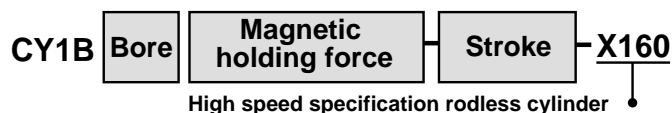

Makes possible high speed piston drive of 1500mm/s (without load).

Specifications

Applicable series	CY1B
Bore size	$\phi 20$ to $\phi 63$
Piston speed (without load)	1500mm/s

Note 1) When operating this cylinder at high speed, a shock absorber must be provided.
Note 2) CY1S and CY1L with standard specifications are capable of a maximum piston speed of 1000mm/s.

11 Helical insert screw specifications -X168

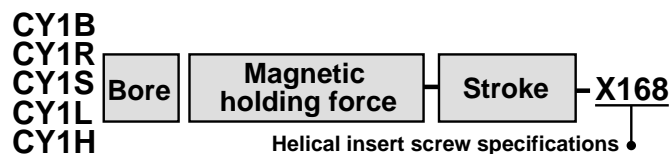

The standard mounting screws have been changed to helical insert screw specifications.

Specifications

Applicable series	CY1B/CY1R/CY1S/CY1L/CY1H
Bore size	CY1B/CY1R: $\phi 20$ to $\phi 63$ CY1S/CY1L: $\phi 20$ to $\phi 40$ CY1H: $\phi 20$ to $\phi 32$

Series CY1

Order Made Specifications 5

Contact SMC for detailed specifications, lead times and prices, etc.

12 Added mounting tap positions for slider Symbol -X206

CY1B Bore Magnetic holding force Stroke **X206**

Added mounting tap positions for slider

Mounting taps have been added on the surface opposite the standard positions.

Specifications

Applicable series	CY1B
Bore size	ø6 to ø63

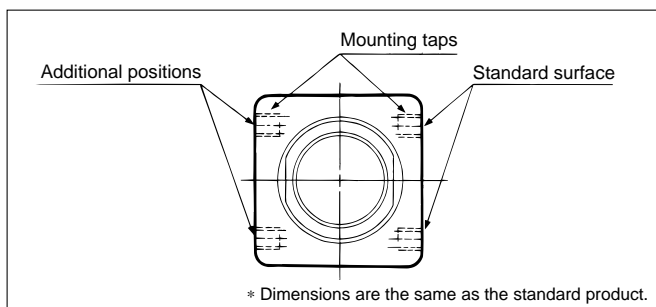

13 Oil-free exterior specifications Symbol -X210

CY1B Bore Magnetic holding force Stroke **X210**
CY1S

Oil-free exterior specifications

Suitable for environments where oils are not tolerated. A scraper is not installed. A separate version -X324 (with felt) has been prepared for cases in which dust, etc. is scattered throughout the environment.

Specifications

Applicable series	CY1B/CY1S	
Bore size	CY1B	ø6 to ø63
	CY1S	ø6 to ø40

Construction

CY1B (basic type)

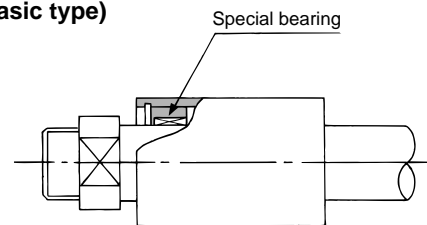

CY1S (slider type)

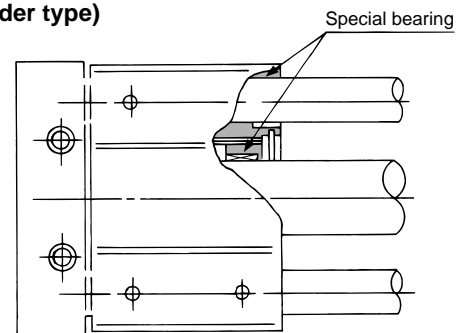

14 CY series mounting dimensions Symbol -X211

CY1B Bore Magnetic holding force Stroke **X211**
CY1S

CY series mounting dimensions

Mounting dimensions have been matched to those of the CY series for maintenance applications.

Specifications

Applicable series	CY1B/CY1S
Bore size	ø15, ø25, ø32, ø40

*The magnet holding force is the same value as the CY series.

Series CY1

Order Made Specifications 6

Contact SMC for detailed specifications, lead times and prices, etc.

15 Outside of cylinder tube with hard chrome plating -X322

Symbol

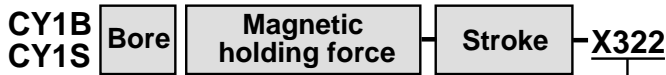

Outside of cylinder tube with hard chrome plating

The outside of the cylinder tube has been plated with hard chromium, reducing wear on the bearings. Furthermore, the piston bearing (wear ring A) has been lengthened, and a grease filling hole has been provided on the CY1S (slide block).

Specifications

Applicable series	Bore size
*CY1B	ø15 to ø63
CY1S	ø15 to ø40

* Since a piston bumper is not installed on the CY1B (basic type), a shock absorber must be provided.

Construction/Dimensions

CY1B (basic type)

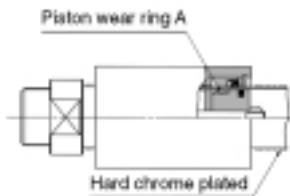

CY1S (slider type)

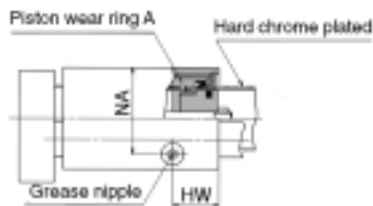

Bore size (mm)	(mm)	
	NA	HW
15	12.5	30
20	10.0	35
25	17.0	21
32	25.5	28
40	32.5	30

16 Oil-free exterior specifications (with dust seal) -X324

Symbol

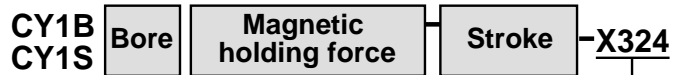

Oil-free exterior specifications (with dust seal)

This unit has oil-free exterior specifications, with a felt dust seal provided on the cylinder body.

Specifications

Applicable series	CY1B/CY1S
Bore size	ø10 to ø63
	ø10 to ø40

Construction/Dimensions

CY1B (basic type)

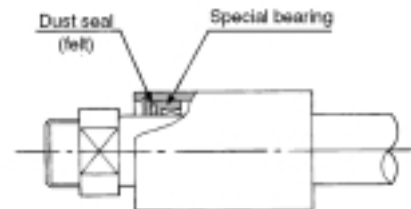

CY1S (slider type)

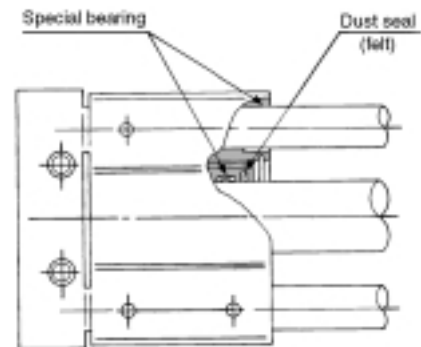

17 Switch rail mounting on both sides (with 2pcs.) -X431

Symbol

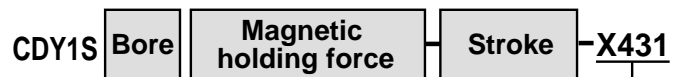

Switch rail mounting on both sides (with 2pcs.)

Effective in cases with switches when the stroke is short.

Specifications

Applicable series	CY1S
Bore size	ø6 to ø40

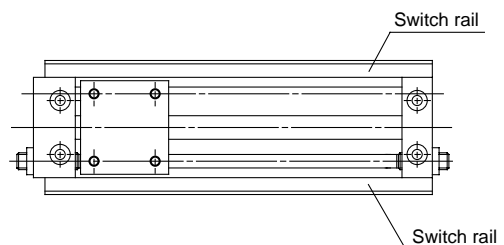





Series CY1

Safety Instructions

These safety instructions are intended to prevent a hazardous situation and/or equipment damage. These instructions indicate the level of potential hazard by a label of "**Caution**", "**Warning**" or "**Danger**". To ensure safety, be sure to observe ISO 4414 Note 1), JIS B 8370 Note 2) and other safety practices.

 **Caution** : Operator error could result in injury or equipment damage.

 **Warning** : Operator error could result in serious injury or loss of life.

 **Danger** : In extreme conditions, there is a possible result of serious injury or loss of life.

Note 1) ISO 4414 : Pneumatic fluid power – Recommendations for the application of equipment to transmission and control systems.

Note 2) JIS B 8370 : Pneumatic system axiom.

Warning

1 The compatibility of pneumatic equipment is the responsibility of the person who designs the pneumatic system or decides its specifications.

Since the products specified here are used in various operating conditions, their compatibility for the specific pneumatic system must be based on specifications or after analysis and/or tests to meet your specific requirements.

2 Only trained personnel should operate pneumatically operated machinery and equipment.

Compressed air can be dangerous if an operator is unfamiliar with it. Assembly, handling or repair of pneumatic systems should be performed by trained and experienced operators.

3 Do not service machinery/equipment or attempt to remove components until safety is confirmed.

1. Inspection and maintenance of machinery/equipment should only be performed after confirmation of safe locked-out control positions.
2. When equipment is to be removed, confirm the safety process as mentioned above. Cut the supply pressure for this equipment and exhaust all residual compressed air in the system.
3. Before machinery/equipment is restarted, take measures to prevent shooting-out of cylinder piston rod, etc. (Bleed air into the system gradually to create back-pressure.)

4 Contact SMC if the product is to be used in any of the following conditions:

1. Conditions and environments beyond the given specifications, or if product is used outdoors.
2. Installation on equipment in conjunction with atomic energy, railway, air navigation, vehicles, medical equipment, food and beverages, recreation equipment, emergency stop circuits, press applications, or safety equipment.
3. An application which has the possibility of having negative effects on people, property, or animals, requiring special safety analysis.



Series CY1 Actuator Precautions 1

Be sure to read before handling.

Precautions on design

Warning

- 1. There is a possibility of dangerous sudden action by air cylinders if sliding parts of machinery are twisted due to external forces, etc.**

In such cases, human injury may occur; e.g., by catching hands or feet in the machinery, or damage to the machinery itself may occur. Therefore, the machine should be designed to avoid such dangers.

- 2. A protective cover is recommended to minimize the risk of personal injury.**

If a stationary object and moving parts of a cylinder are in close proximity, personal injury may occur. Design the structure to avoid contact with the human body.

- 3. Securely tighten all stationary parts and connected parts so that they will not become loose.**

When a cylinder operates with high frequency or a cylinder is installed where there is a lot of vibration, ensure that all parts remain secure.

- 4. A deceleration circuit or shock absorber, etc., may be required.**

When a driven object is operated at high speed or the load is heavy, a cylinder's cushion will not be sufficient to absorb the shock. Install a deceleration circuit to reduce the speed before cushioning, or install an external shock absorber to relieve the shock. In this case, the rigidity of the machinery should also be examined.

- 5. Consider a possible drop in operating pressure due to a power outage, etc.**

When a cylinder is used in a clamping mechanism, there is a danger of work dropping if there is a decrease in clamping force due to a drop in circuit pressure caused by a power outage, etc. Therefore, safety equipment should be installed to prevent damage to machinery and human injury. Suspension mechanisms and lifting devices also require consideration for drop prevention.

- 6. Consider a possible loss of power source.**

Measures should be taken to protect against human injury and equipment damage in the event that there is a loss of power to equipment controlled by air pressure, electricity or hydraulics, etc.

- 7. Design circuitry to prevent sudden lurching of driven objects.**

When a cylinder is driven by an exhaust center type directional control valve or when starting up after residual pressure is exhausted from the circuit, etc., the piston and its driven object will lurch at high speed if pressure is applied to one side of the cylinder because of the absence of air pressure inside the cylinder. Therefore, equipment should be selected and circuits designed to prevent sudden lurching, because there is a danger of human injury and/or damage to equipment when this occurs.

- 8. Consider emergency stops.**

Design so that human injury and/or damage to machinery and equipment will not be caused when machinery is stopped by a safety device under abnormal conditions, a power outage or a manual emergency stop.

- 9. Consider the action when operation is restarted after an emergency stop or abnormal stop.**

Design the machinery so that human injury or equipment damage will not occur upon restart of operation. When the cylinder has to be reset at the starting position, install manual safety equipment.

Selection

Warning

- 1. Check the specifications.**

The products advertised in this catalog are designed according to use in industrial compressed air systems. If the products are used in conditions where pressure, temperature, etc., are out of specification, damage and/or malfunction may be caused. Do not use in these conditions.

Consult SMC if you use a fluid other than compressed air.

- 2. Intermediate stops.**

When intermediate stopping of a cylinder piston is performed with a 3 position closed center type directional control valve, it is difficult to achieve stopping positions as accurate and minute as with hydraulic pressure, due to the compressibility of air.

Furthermore, since valves and cylinders, etc. are not guaranteed for zero air leakage, it may not be possible to hold a stopped position for an extended period of time. Contact SMC in case it is necessary to hold a stopped position for an extended period.

Caution

- 1. Operate within the limits of the maximum usable stroke.**

Refer to the selection procedures for the type of air cylinder to be used for the maximum usable stroke.

- 2. Operate the piston within a range such that collision damage will not occur at the end of the stroke.**

Operate within a range such that damage will not occur when the piston having inertial force stops by striking the cover at the stroke end. Refer to the cylinder type selection procedure for the range within which damage will not occur.

- 3. Use a speed controller to adjust the cylinder drive speed, gradually increasing from a low speed to the desired speed setting.**



Series CY1 Actuator Precautions 2

Be sure to read before handling.

Mounting

⚠ Caution

1. Align carefully when connecting to a load having an external guide mechanism.

Since variation of the shaft center becomes greater as the stroke becomes longer, a connection method (floating mechanism) should be considered which can assimilate this variation.

Moreover, consideration should be given to the exclusive floating joint (XC 57), which has been created for series CY1B and CY1R.

2. When an external guide is used, connect the external slider and the load in such a way that there is no interference at any point within the stroke.

3. Do not scratch or dent the sliding parts of the cylinder tube by striking or grasping them with other objects.

Cylinder bores are manufactured to precise tolerances, so that even a slight deformation may cause faulty operation.

4. Do not use until you verify that the equipment can operate properly.

After mounting, repair or modification, etc., connect the air supply and electric power, and then confirm proper mounting by means of appropriate function and leak inspections.

5. Instruction manual.

The product should be mounted and operated after thoroughly reading the manual and understanding its contents.

Keep the instruction manual where it can be referred to as needed.

Piping

⚠ Caution

1. Preparation before piping.

Before piping is connected, it should be thoroughly blown out with air (flushing) or washed to remove cutting chips, cutting oil and other debris from inside the pipe.

2. Wrapping of pipe tape.

When connecting pipes and fittings, etc., be certain that cutting chips from the pipe threads and sealing material do not get inside the piping.

Also, when pipe tape is used, leave 1.5 to 2 thread ridges exposed at the end of the pipe/fitting.

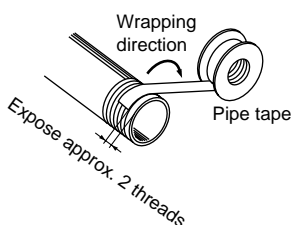

Lubrication

⚠ Caution

1. Lubrication of cylinder.

The cylinder has been lubricated for life at the factory and can be used without any further lubrication.

However, in the event that it will be lubricated, use class 1 turbine oil (with no additives) ISO VG32.

Stopping lubrication later may lead to malfunction due to the loss of the original lubricant. Therefore, lubrication must be continued once it has been started.

Air Supply

⚠ Warning

1. Use clean air.

If compressed air includes chemicals, synthetic oils containing organic solvents, salt or corrosive gases, etc., it can cause damage or malfunction.

⚠ Caution

1. Install air filters.

Install air filters at the upstream side of valves. The filtration degree should be 5 μ m or less.

2. Install an air dryer, after cooler, etc.

Air that includes excessive condensate may cause malfunction of valves and other pneumatic equipment. To prevent this, install an air dryer, after cooler, etc.

3. Use the product within the specified range of fluid and ambient temperature.

Take measures to prevent freezing, since moisture in circuits will be frozen under 5°C, and this may cause damage to seals and lead to malfunction.

Refer to SMC's "Air Cleaning Equipment" catalog for further details on compressed air quality.



Series CY1 Actuator Precautions 3

Be sure to read before handling.

Operating Environment

Warning

1. **Do not use in environments where there is a danger of corrosion.**

Refer to the construction drawings regarding cylinder materials.

2. **In dirty areas, such as dusty locations or where water, oil, etc. splash on the equipment, take suitable protective measures.**

Contact SMC in cases where dust or water, etc. will be scattered throughout the area.

Maintenance

Warning

1. **Maintenance should be done according to the procedure indicated in the operating manual.**

If handled improperly, malfunction and damage of machinery or equipment may occur.

2. **Machine maintenance, and supply and exhaust of compressed air.**

When machinery is serviced, first check measures to prevent dropping of driven objects and run-away of equipment, etc. Then cut off the supply pressure and electric power, and exhaust all compressed air from the system.

When machinery is restarted, check that operation is normal with actuators in the proper positions.

Caution

1. **Drain flushing.**

Remove condensate from air filters regularly. (Refer to specifications.)



Series CY1 Auto Switch Precautions 1

Be sure to read before handling.

Design & Selection

Warning

1. Confirm the specifications.

Read the specifications carefully and use this product appropriately. The product may be damaged or malfunction if it is used outside the range of specifications of current load, voltage, temperature or impact.

2. Take precautions when multiple cylinders are used close together.

When multiple auto switch cylinders are used in close proximity, magnetic field interference may cause the switches to malfunction. Maintain a minimum cylinder separation of 40mm. (When the allowable separation is indicated for each cylinder series, use the specified value.)

3. Pay attention to the length of time that a switch is ON at an intermediate stroke position.

When an auto switch is placed at an intermediate position of the stroke and a load is driven at the time the piston passes, the auto switch will operate, but if the speed is too great the operating time will be shortened and the load may not operate properly. The maximum detectable piston speed is:

$$V(\text{mm/s}) = \frac{\text{Auto switch operating range (mm)}}{\text{Time load applied (ms)}} \times 1000$$

In cases of high piston speed, the use of an auto switch (F7NT) with a built-in OFF delay timer (approx. 200ms) makes it possible to extend the load operating time.

4. Wiring should be kept as short as possible.

<Reed switch>

As the length of the wiring to a load gets longer, the rush current at switching ON becomes greater, and this may shorten the product's life. (The switch will stay ON all the time.)

- 1) For an auto switch without a contact protection circuit, use a contact protection box when the wire length is 5m or longer.
- 2) Even if an auto switch has a built-in contact protection circuit, when the wiring is more than 30m long, it is not able to adequately absorb the rush current and its life may be reduced. It is again necessary to connect a contact protection box in order to extend its life. Please contact SMC in this case.

<Solid state switch>

- 3) Although wire length should not affect switch function, use a wire 100m or shorter.

5. Take precautions for the internal voltage drop of the switch.

<Reed switch>

- 1) Switches with an indicator light (Except A76H, A96 and Z76)
 - If auto switches are connected in series as shown below, take note that there will be a large voltage drop because of internal resistance in the light emitting diode. (Refer to internal voltage drop in the auto switch specifications.)

[The voltage drop will be "n" times larger when "n" auto switches are connected.]

Even though an auto switch operates normally, the load may not operate.



Warning

- In the same way, when operating under a specified voltage, although an auto switch may operate normally, the load may not operate. Therefore, the formula below should be satisfied after confirming the minimum operating voltage of the load.

$$\text{Supply voltage} - \text{Internal voltage drop of switch} > \text{Minimum operating voltage of load}$$

- 2) If the internal resistance of a light emitting diode causes a problem, select a switch without an indicator light (Model A80, A80H, A90 and Z80).

<Solid state switch>

- 3) Generally, the internal voltage drop will be greater with a 2 wire solid state auto switch than with a reed switch. Take the same precautions as in 1).

Also, note that a 12VDC relay is not applicable.

6. Pay attention to leakage current.

<Solid state switch>

With a 2 wire solid state auto switch, current (leakage current) flows to the load to operate the internal circuit even when in the OFF state.

$$\text{Operating current of load (OFF condition)} > \text{Leakage current}$$

If the criteria given in the above formula are not met, it will not reset correctly (stays ON). Use a 3 wire switch if this specification will not be satisfied.

Moreover, leakage current flow to the load will be "n" times larger when "n" auto switches are connected in parallel.

7. Do not use a load that generates surge voltage.

<Reed switch>

If driving a load such as a relay that generates a surge voltage, use a switch with a built-in contact protection circuit or use a contact protection box.

<Solid state switch>

Although a zener diode for surge protection is connected at the output side of a solid state auto switch, damage may still occur if the surge is applied repeatedly. When a load, such as a relay or solenoid, which generates surge is directly driven, use a type of switch with a built-in surge absorbing element.

8. Cautions for use in an interlock circuit.

When an auto switch is used for an interlock signal requiring high reliability, devise a double interlock system to avoid trouble by providing a mechanical protection function, or by also using another switch (sensor) together with the auto switch. Also perform periodic maintenance and confirm proper operation.

9. Ensure sufficient clearance for maintenance activities.

When designing an application, be sure to allow sufficient clearance for maintenance and inspections.



Series CY1 Auto Switch Precautions 2

Be sure to read before handling.

Mounting & Adjustment

Warning

1. Do not drop or bump.

Do not drop, bump or apply excessive impacts (300m/s² or more for reed switches and 1000m/s² or more for solid state switches) while handling.

Although the body of the switch may not be damaged, the inside of the switch could be damaged and cause a malfunction.

2. Do not carry a cylinder by the auto switch lead wires.

Never carry a cylinder by its lead wires. This may not only cause broken lead wires, but it may cause internal elements of the switch to be damaged by the stress.

3. Mount switches using the proper fastening torque.

When a switch is tightened beyond the range of fastening torque, the mounting screws, mounting bracket or switch may be damaged. On the other hand, tightening below the range of fastening torque may allow the switch to slip out of position. (Refer to switch mounting for each series regarding switch mounting, moving, and fastening torque, etc.)

4. Mount a switch at the center of the operating range.

Adjust the mounting position of an auto switch so that the piston stops at the center of the operating range (the range in which a switch is ON).

(The mounting position shown in a catalog indicates the optimum position at stroke end.) If mounted at the end of the operating range (around the borderline of ON and OFF), operation will be unstable.

Wiring

Warning

1. Avoid repeatedly bending or stretching lead wires.

Broken lead wires will result from applying bending stress or stretching force to the lead wires.

2. Be sure to connect the load before power is applied.

<2 wire type>

If the power is turned ON when an auto switch is not connected to a load, the switch will be instantly damaged because of excess current.

3. Confirm proper insulation of wiring.

Be certain that there is no faulty wiring insulation (contact with other circuits, ground fault, improper insulation between terminals, etc.). Damage may occur due to excess current flow into a switch.

4. Do not wire with power lines or high voltage lines.

Wire separately from power lines or high voltage lines, avoiding parallel wiring or wiring in the same conduit with these lines. Control circuits, including auto switches, may malfunction due to noise from these other lines.

Wiring

Warning

5. Do not allow short circuit of loads.

<Reed switch>

If the power is turned ON with a load in a short circuit condition, the switch will be instantly damaged because of excess current flow into the switch.

<Solid state switch>

Model D-F9□, F-9□W and all models of PNP output type switches do not have built-in short circuit prevention circuits. If loads are short circuited, the switches will be instantly damaged.

Take special care to avoid reverse wiring with the brown (red) power supply line and the black (white) output line on 3 wire type switches.

6. Avoid incorrect wiring.

<Reed switch>

A 24VDC switch with indicator light has polarity. The brown lead wire or terminal No. 1 is (+), and the blue lead wire or terminal No. 2 is (-).

[In the case of model D-97, the side without indicator is (+), and the black line side is (-).]

- 1) If connections are reversed, a switch will operate, however, the light emitting diode will not light up.

Also note that a current greater than that specified will damage a light emitting diode and it will no longer operate.

Applicable models: D-A73, A73H, A73C, Z73, D-A93

<Solid state switch>

- 1) If connections are reversed on a 2 wire type switch, the switch will not be damaged if protected by a protection circuit, but the switch will always stay in an ON state. However, it is still necessary to avoid reversed connections, since the switch could be damaged by a load short circuit in this condition.
- 2) If connections are reversed (power supply line + and power supply line -) on a 3 wire type switch, the switch will be protected by a protection circuit. However, if the power supply line (+) is connected to the blue (black) wire and the power supply line (-) is connected to the black (white) wire, the switch will be damaged.

* Lead wire color changes

Lead wire colors of SMC switches and related products have been changed in order to meet NECA (Nippon Electric Control Equipment Industries Association) Standard 0402 for production beginning September, 1996 and thereafter. Please refer to the tables provided.

Special care should be taken regarding wire polarity during the time that the old colors still coexist with the new colors.

2 wire

	Old	New
Output (+)	Red	Brown
Output (-)	Black	Blue

3 wire

	Old	New
Power supply	Red	Brown
GND	Black	Blue
Output	White	Black

Solid state with diagnostic output

	Old	New
Power supply	Red	Brown
GND	Black	Blue
Output	White	Black
Diagnostic Output	Yellow	Orange

Solid state with latch type diagnostic output

	Old	New
Power supply	Red	Brown
GND	Black	Blue
Output	White	Black
Latch type diagnostic Output	Yellow	Orange



Series CY1 Auto Switch Precautions 3

Be sure to read before handling.

Operating Environment

Warning

1. Never use in an atmosphere of explosive gases.

The structure of auto switches is not intended to prevent explosion. Never use in an atmosphere with an explosive gas since this may cause a serious explosion.

2. Do not use in an area where a magnetic field is generated.

Auto switches will malfunction or magnets inside cylinders will become demagnetized. (Consult SMC regarding the availability of a magnetic field resistant auto switch.)

3. Do not use in an environment where the auto switch will be continually exposed to water.

Although switches satisfy the IEC standard IP67 structure (JIS C 0920: anti-immersion structure), do not use switches in applications where continually exposed to water splash or spray. Poor insulation or swelling of the potting resin inside switches may cause malfunction.

4. Do not use in an environment with oil or chemicals.

Consult SMC if auto switches will be used in an environment with coolant, cleaning solvent, various oils or chemicals. If auto switches are used under these conditions for even a short time, they may be adversely affected by improper insulation, malfunction due to swelling of the potting resin, or hardening of the lead wires.

5. Do not use in an environment with temperature cycles.

Consult SMC if switches are used where there are temperature cycles other than normal temperature changes, as they may be adversely affected.

6. Do not use in an environment where there is excessive impact shock.

<Reed switch>

When excessive impact (300m/s² or more) is applied to a reed switch during operation, the contact point will malfunction and generate or cut off a signal momentarily (1ms or less). Consult SMC regarding the need to use a solid state switch depending upon the environment.

7. Do not use in an area where surges are generated.

<Solid state switch>

When there are units (solenoid type lifter, high frequency induction furnace, motor, etc.) which generate a large amount of surge in the area around cylinders with solid state auto switches, this may cause deterioration or damage to the switch. Avoid sources of surge generation and disorganized lines.

8. Avoid accumulation of iron powder or close contact with magnetic substances.

When a large amount of ferrous powder such as machining chips or spatter is accumulated, or a magnetic substance (something attracted by a magnet) is brought into close proximity with an auto switch cylinder, it may cause the auto switch to malfunction due to a loss of the magnetic force inside the cylinder.

Maintenance

Warning

1. Perform the following maintenance periodically in order to prevent possible danger due to unexpected auto switch malfunction.

1) Secure and tighten switch mounting screws.

If screws become loose or the mounting position is dislocated, retighten them after readjusting the mounting position.

2) Confirm that there is no damage to lead wires.

To prevent faulty insulation, replace switches or repair lead wires, etc., if damage is discovered.

3) Confirm the lighting of the green light on the 2 color indicator type switch.

Confirm that the green LED is on when stopped at the established position. If the red LED is on, the mounting position is not appropriate. Readjust the mounting position until the green LED lights up.

Other

Warning

1. Consult SMC concerning water resistance, elasticity of lead wires, and usage at welding sites, etc.



SMC'S GLOBAL MANUFACTURING, DISTRIBUTION AND SERVICE NETWORK

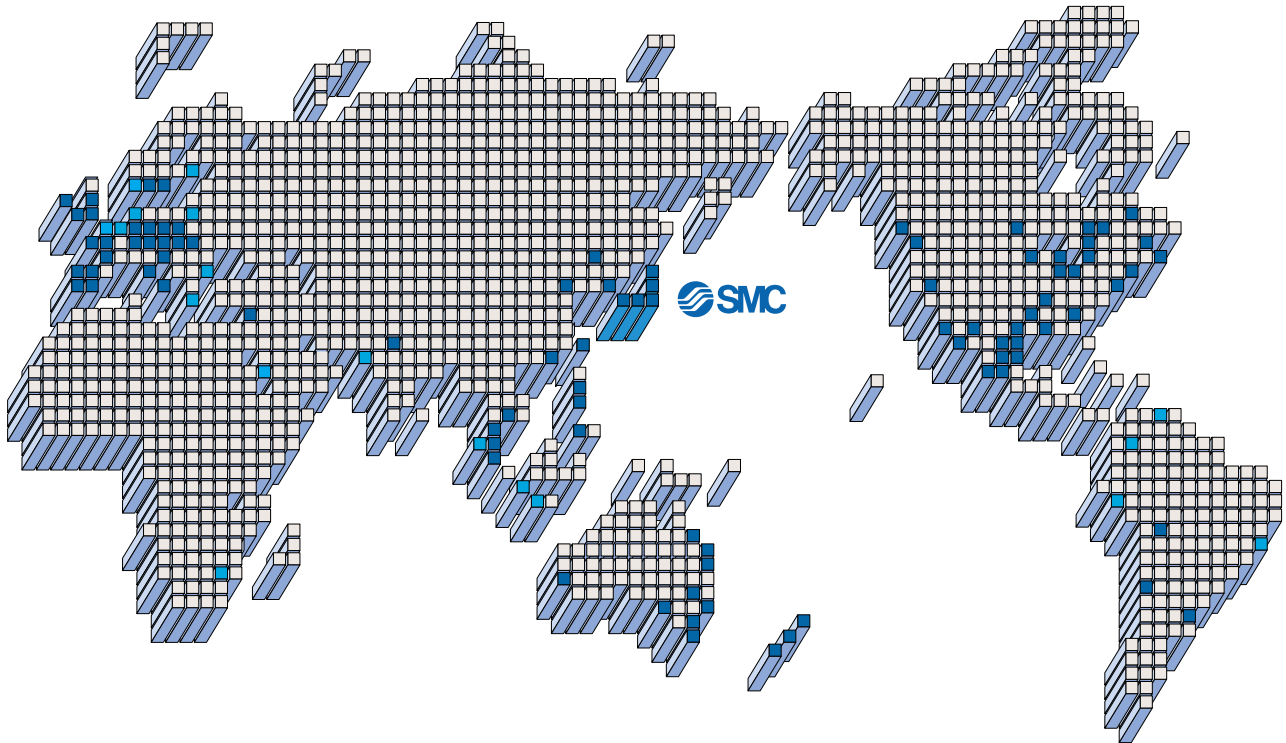

EUROPE

AUSTRIA

SMC Pneumatik GmbH.

CZECH

SMC Czech s.r.o.

FRANCE

SMC Pneumatique SA

GERMANY

SMC Pneumatik GmbH

HUNGARY

SMC Hungary Kft.

IRELAND

SMC Pneumatics (Ireland) Ltd.

ITALY/ROMANIA

SMC Italia S.p.A.

NETHERLANDS

SMC Controls BV.

SLOVAKIA

SMC Slovakia s.r.o.

SLOVENIA

SMC Slovenia d.o.c.

SPAIN/PORTUGAL

SMC Espana, S.A.

SWEDEN

SMC Pneumatics Sweden AB

SWITZERLAND

SMC Pneumatik AG.

UK

SMC Pneumatics (U.K.) Ltd.

ASIA

CHINA

SMC (China) Co., Ltd.

HONG KONG

SMC Pneumatics (Hong kong) Ltd.

INDIA

SMC Pneumatics (India) Pvt. Ltd.

MALAYSIA

SMC Pneumatics (S.E.A.) Sdn. Bhd.

PHILIPPINES

SMC Pneumatics (Philippines), Inc.

SINGAPORE

SMC Pneumatics (S.E.A.) Pte. Ltd.

SOUTH KOREA

SMC Pneumatics Korea Co., Ltd.

TAIWAN

SMC Pneumatics (Taiwan) Co., Ltd.

THAILAND

SMC Thailand Ltd.

NORTH AMERICA

CANADA

SMC Pneumatics (Canada) Ltd.

MEXICO

SMC Corporation (Mexico) S.A. de C.V.

USA

SMC Pneumatics Inc.

SOUTH AMERICA

ARGENTINA

SMC Argentina S.A.

BOLIVIA

SMC Pneumatics Bolivia S.R.L.

CHILE

SMC Pneumatics (Chile) S.A.

VENEZUELA

SMC Neumatica Venezuela S.A.

OCEANIA

AUSTRALIA

SMC Pneumatics (Australia) Pty. Ltd.

NEW ZEALAND

SMC Pneumatics (N.Z.) Ltd.

SMC CORPORATION

1-16-4 Shimbashi, Minato-ku, Tokyo 105 JAPAN
Tel: 03-3502-2740 Fax: 03-3508-2480