

BALDOR® • RELIANCE 

Product Information Packet

AUTOMATION DISTRIBUTION INC.

EM5001A02SP

SMART SENSOR KIT NEMA 250-360 CAST IRON

Parts List		
Part Number	Description	Quantity
EM5001A02	SMART SENSOR KIT NEMA 250-360 CAST IRON	1.000 EA
MJ5004A90	ADHESIVE - LOCTITE 3463 EPOXY STICK 4OZ	1.000 EA
MN444	INSTRUCTION MANUAL FOR ABB SMART SENSOR	1.000 EA
99181U	LABEL,3"X 15/16"4-ACROSS,48-UP	1.000 EA
PK1292	FOLDING CARTON - SMART SENSOR	1.000 EA

EM5001

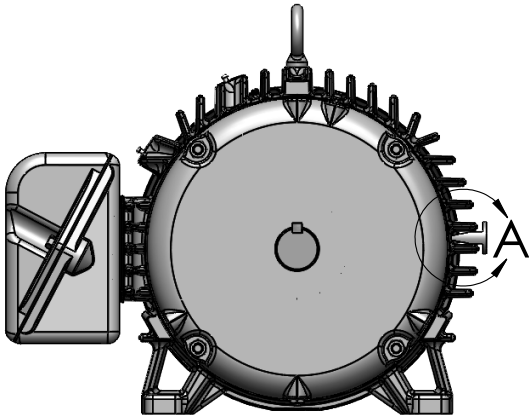

RECEIVER LOCATION
(SEE NOTE #1)

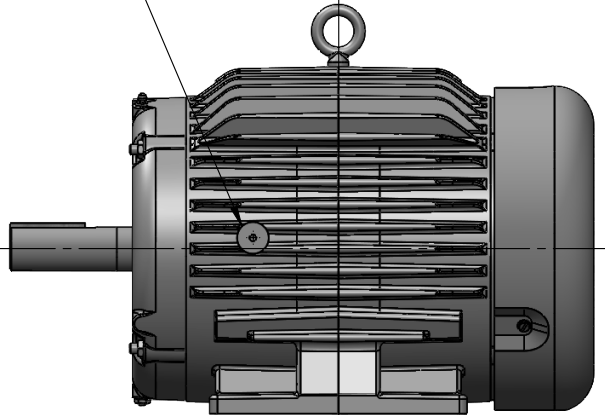

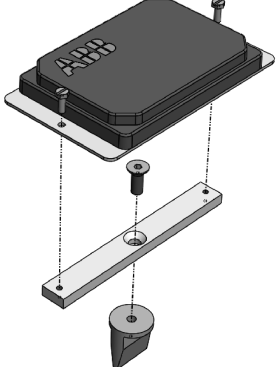

SMART SENSOR KIT ASSEMBLY

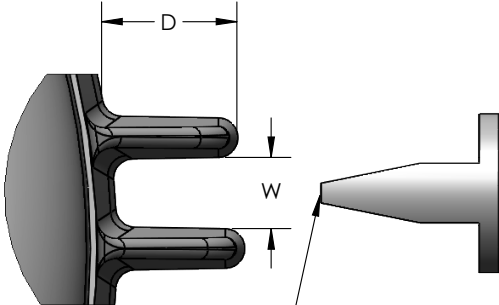

DETAIL "A"

THIS SURFACE MUST MAKE DIRECT CONTACT WITH THE MOTOR FRAME

(#2) FIN DIMENSION CHART				(#3) BALDOR SMART SENSOR KIT PART #	TYPICALLY FITS THE FOLLOWING BALDOR NEMA FRAMES
D		W			
MIN.	MAX.	MIN.	MAX.		
0.50	1.00	0.50	0.75	EM5001A01SP	140-210
0.75	1.25	0.75	1.00	EM5001A02SP	250-360
1.00	1.63	0.50	0.75	EM5001A03SP	400-449

KIT SELECTION INSTRUCTIONS

#1 - RECEIVER MUST BE CENTRALLY LOCATED BETWEEN CENTER OF MOTOR AND DRIVE END BEARING AS ILLUSTRATED ABOVE.

#2 - USE THIS CHART WHEN MESURING THE FINS ON YOUR MOTOR.

#3 - ONCE YOU HAVE DETERMINED WHICH MIN./MAX. DIMENSIONS BEST FIT YOUR MOTOR FIN DESIGN, SELECT YOUR BALDOR SMART SENSOR KIT (I.E.; EM5001A0_SP).

CUSTOMER IS RESPONSIBLE FOR DETERMINING THAT BALDOR'S PRODUCT WILL PERFORM SUITABLY IN THE INTENDED APPLICATION

REV. DESC: NEW				BALDOR		EM5001
REV: -	VERSION: 00	REVISED: 09:16:29 10/10/2016	TDR: 000000989676			
1005W3		MODEL NO. EM5001	REF: -			
		BY: ENERIO0				

!! Produit préliminaire !!
Non valable pour la production



B-B (2 : 1)

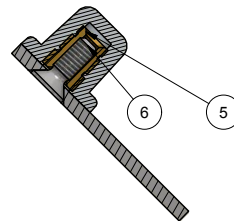

ISO (1 / 2)

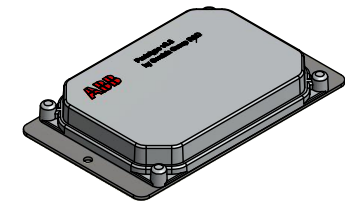

D (2 : 1)

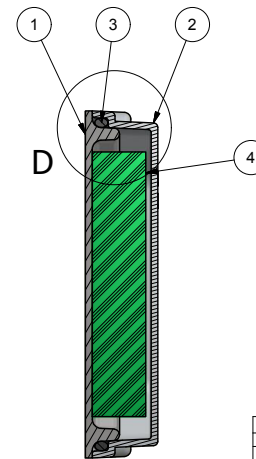
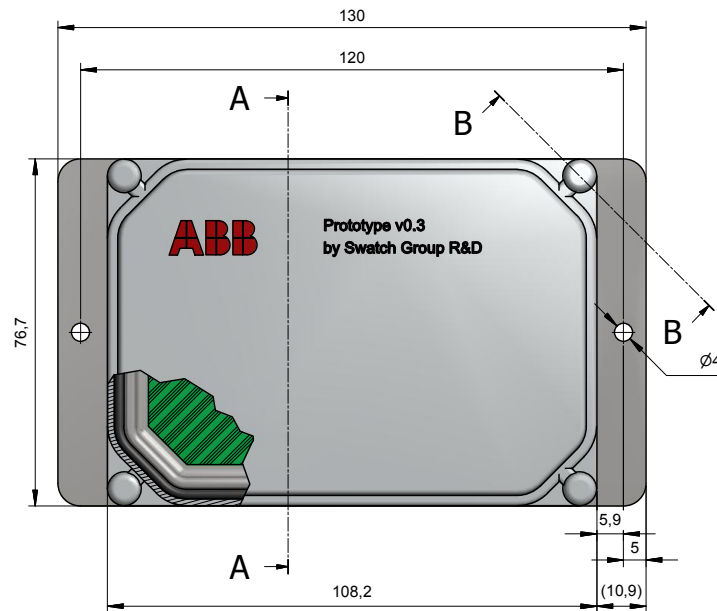
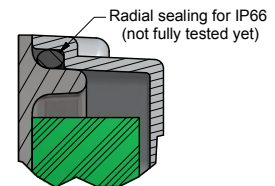

A-A (1 : 1)

Pos.	Qté.	NUMERO DE PIECE	DESCRIPTION
1	1	Baseplate_v0.3	Forged/Matrixed Stainless Steel or Aluminium
2	1	Boitier_v0.3	PC + PBT
3	1	Joint_v0.3	EPDM or Silicon
4	1	PCB_v0.3	
5	4	Insert_v0.3	Ultrasonic Brass Insert Series, thread size M2.5x0.45 ISO
6	4	Vis_v0.3	Vis FX M2.5x0.45 ISO

Dénomination Boitier_ABB_V3		3D Créé	YMosteiro	13.07.2016
		Dessiné	YMosteiro	13.07.2016

Informations générales :
Tolérances générales : ISO 2768 - mK

ASULAB
A DIVISION OF THE SWATCH GROUP RESEARCH AND DEVELOPMENT LTD.
A COMPANY OF THE SWATCH GROUP

Ce document est la propriété de THE SWATCH GROUP RESEARCH AND DEVELOPMENT LTD. et ne doit être communiqué, entretenu ou parélement, à des tiers sans son autorisation expresse.

Ne doit pas être faxé, télétransmis, ou photocopié. Ce document doit être détruit par des moyens appropriés.