



ROBOTIQ PE20 PALLETIZING *SOLUTION*

Original instructions (en)

© 2024 Robotiq Inc.

Robotiq PE20 Palletizing Solution
for Universal Robots



User Manual

LEAN 
ROBOTICS

robotiq.com | leanrobotics.org

Table of Contents

Revisions	4
1. General Presentation	6
1.1. Palletizing Solution Components	6
2. Safety	8
2.1. Disclaimer	8
2.2. Risk Assessment	9
2.3. Use of the Solution	14
3. Installation	19
3.1. Scope of Delivery	20
3.2. Required Tools and Equipment	22
3.3. Environmental and Operating Conditions	23
3.4. Mounting and Installation	24
3.5. Other Grippers	58
3.6. URCap Package	60
3.7. Robot Configurations	61
4. Operation	63
4.1. Start Up	63
4.2. Palletizing Operation Instructions	63
4.3. Palletizing Operation Diagrams	65
4.4. Status Light States	66
4.5. Solution Mobility (Wash Down and Production Line Shifts)	67
5. URCap Software	74
5.1. License Agreement	74
5.2. Copilot	77
5.3. Command Window	78
5.4. Program Tree	102
5.5. Palletizing Script Functions	111
6. Specifications	116
6.1. Technical Dimensions	116
6.2. Mechanical Specifications	117



6.3. Electrical Specifications	118
7. Periodic Inspection and Maintenance	120
7.1. Power Off and Lock Off Procedure	120
7.2. Inspection	121
7.3. Fastener Specifications	124
7.4. Cleaning	125
7.5. Storage	125
8. Spare Parts, Kits and Accessories	126
8.1. PowerPick20 (Optional Gripper) Spare Parts & Accessories	127
9. Troubleshooting	129
9.1. Palletizing Solution (excluding the PowerPick20 Vacuum Gripper)	129
9.2. PowerPick20 Vacuum Gripper (Optional)	132
10. Warranty	133
11. Harmonized Standards	135
11.1. EC Declaration of Incorporation	135
11.2. Identification plate	137
12. Appendix	138
12.1. Palletizing Cell Layout	138
12.2. Conveyor Positioning Holes	140
12.3. Overhang Spacers	141
12.4. Pneumatic Diagram	142
13. Contact	143



Revisions

Robotiq may modify this product without notice, when necessary, due to product improvements, modifications or changes in specifications. If such modifications are made, the manual will also be revised. See revision information below. The latest version of this manual can be downloaded at support.robotiq.com.

2024/03/25

New section for the use of force sensing for heavy payload.

2024/03/05

Amended the electrical diagram of the Palletizing Solution as well as the power and control section to account for updates to the control box connections.

2024/02/12

Updated the manual to account for the latest changes to the PowerPick20 Vacuum Gripper.

2023/12/18

- Updated spare parts
- Maintenance section revision
- New software features added for Multi-recipe
- New script functions added: Use Payload with Box, Use Payload No Box & Set Box Payload

2023/09/05

Initial Release



Copyright

© 2023 Robotiq Inc. All rights reserved.

This manual and the product it describes are protected by the Copyright Act of Canada, by laws of other countries, and by international treaties, and therefore may not be reproduced in whole or in part, whether for sale or not, without prior written consent from Robotiq. Under copyright law, copying includes translation into another language or format.

Information provided by Robotiq in this document is believed to be accurate and reliable. However, Robotiq shall accept no responsibility for its use. There may be some differences between the manual and the product if the product has been modified after the editing date.

The information contained in this document is subject to change without notice.



1. General Presentation

The terms "Palletizer", "Palletizing Solution", "Robotiq Palletizing Solution", "Solution" and "PE20" used in this manual all refer to the Robotiq PE20 Palletizing Solution for UR20 Universal Robots. The Robotiq PE20 Palletizing Solution is a hardware and software solution preconnected and ready to install. It is composed of a base fully integrated with a Robotiq control box, pallet sensors, a pedestal, and a post with a teach pendant rack and status lights. The standard delivery also contains the Robotiq PowerPick20 Vacuum Gripper and Vacuum Generation Unit. The Material Handling Copilot software and accessories (e.g., box sensor, anchor kit, cable management system, etc.) are also part of the Solution.



CAUTION

This section presents the key features of the Robotiq Palletizing Solution and must not be considered as sufficient knowledge to operate the Solution. Each feature is detailed in the appropriate section.

1.1. Palletizing Solution Components

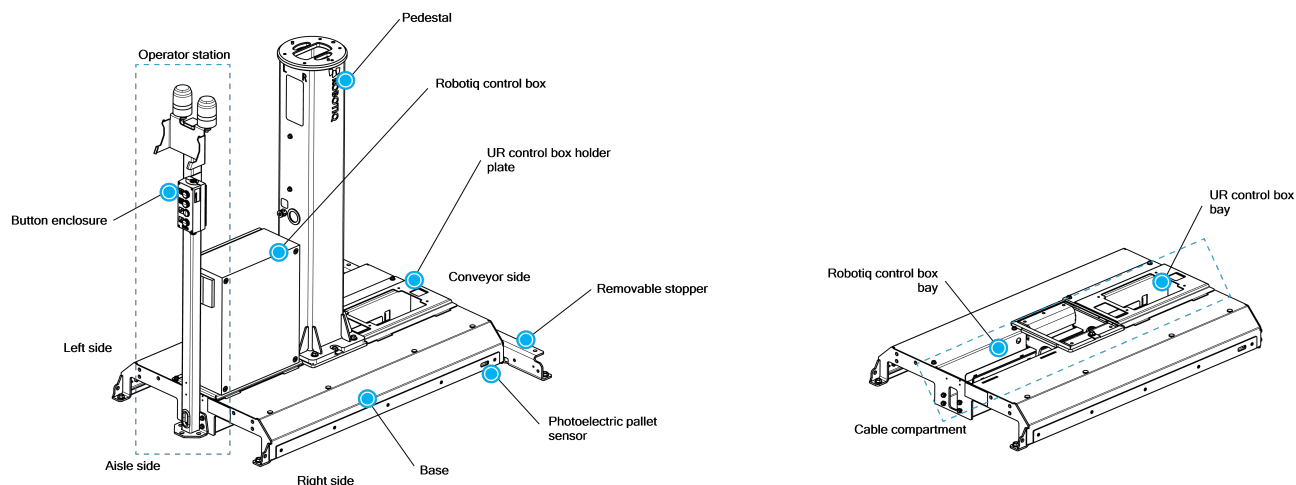

Fig. 1-1: Robotiq PE20 Palletizing Solution

1.1.1. Base, Pedestal and Post

The Robotiq Palletizing Solution is composed of a base, on which a pedestal, pallet sensors and Robotiq control box are mounted, and a post, on which a teach pendant rack, a push button enclosure, and status lights are mounted. The Solution is designed to facilitate the positioning of pallets.

The base has to be anchored to the floor. For more details, please refer to the **Installation** section

1.1.2. Robotiq Control Box

All the components of the Solution are integrated and controlled via the Robotiq control box. It allows for the motion of the robot during a palletizing process, and the control of the pallet sensors and status lights.

1.1.3. Standalone Post

The Solution includes a post to which a push button enclosure, status lights and teach pendant rack are attached. The post can either be mounted to the base or positioned elsewhere, adjacent to the base.



1.1.4. Pallet Sensors

The Solution is composed of two (2) sensors used to detect pallet presence (one for each side of the solution).

1.1.5. Status Lights

Two (2) status lights are positioned at the top of the post adjacent to the base. Each status light is associated with the nearest pallet. The color of the light gives information on the status of the system or the state of a specific pallet. Please refer to the **Status Light States** section for more information.

1.1.6. PowerPick20 Vacuum Gripper (Optional)

PowerPick20 is a vacuum gripper that uses a venturi system to generate vacuum from a compressed air energy source. The PowerPick20 interfaces with the robot via input/output (I/O) cables connected directly to the robot controller.

The kit consists of a gripper, multiple suction cups and interchangeable components, along with a dual-channel vacuum generation unit. The unit also includes a shut-off valve and an integrated filter regulator.

Its design is suitable for the Robotiq Palletizing Solution when used with a UR20 robot (weight, payload, independently controllable channels).

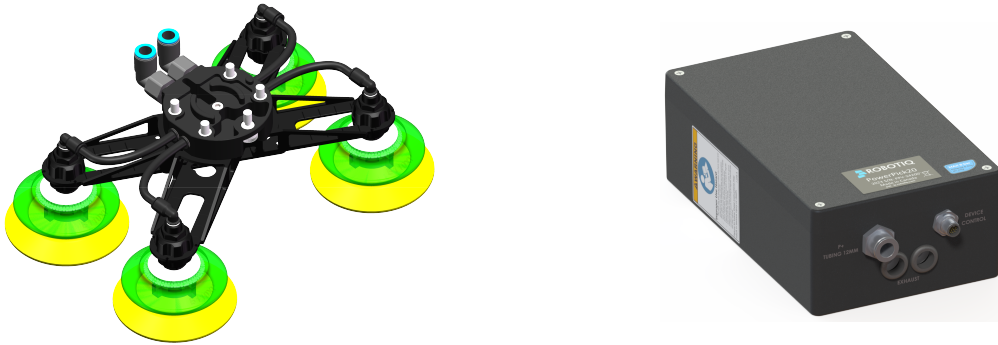

Fig. 1-2: PowerPick20 Gripper and Vacuum Generator

1.1.7. Box Detection Sensor

The Solution includes a box sensor that needs to be installed at the end of the conveyor, and positioned so that it triggers a signal when a box is at the picking position.



Fig. 1-3: Box Sensor

2. Safety

2.1. Disclaimer

The intent of this section is to provide general guidelines for the safe use of the Robotiq Palletizing Solution.

Always follow local regulations.

The installer is responsible for the safe installation and commissioning of the Palletizing Solution.

Robotiq accepts no liability for damage, injury or any legal responsibility incurred directly or indirectly from the use of this product.

The user (installer and operator) shall observe safe and lawful practices including but not limited to those set forth in this document.

The terms *user*, *operator* and *installer*, refer to anyone responsible for any of the following operations on the Robotiq Palletizing Solution:

- Installation
- Control
- Maintenance
- Inspection
- Calibration
- Programming
- Decommissioning.

The present section is based on the following international standards and technical specifications:

- **ISO 10218-1:2011** : Safety Requirements For Industrial Robots - Robots
- **ISO 10218-2:2011** : Safety Requirements For Industrial Robots - Robots Systems and Integrators
- **IEC 60204-1** : Safety Of Machinery - Electrical Equipment Of Machines
- **ISO/TS 15066:2016** : Robots and robotic devices – Collaborative robots



This manual details the components of the Robotiq Palletizing Solution, and the general operations regarding the whole lifecycle of the product, from installation to operation and decommissioning.



The drawings and photos in this manual are representative examples. However, discrepancies may be observed between the visual supports and the actual product.



2.2. Risk Assessment

2.2.1. General Risk Assessment

	 WARNING
	<p>The user must have read and understood all of the instructions in the following manual before operating the Robotiq Palletizing Solution. Any use of the Palletizing Solution in non-compliance with these instructions is deemed inappropriate and may cause injury or damage.</p> <p>It is the user's responsibility to ensure that all local safety measures and regulations are met.</p>

	 WARNING
	<p>Unauthorized Modification</p> <p>DO NOT modify or alter the equipment without the express written consent and approval of the manufacturer.</p>

The entire cell (i.e., the robot, the PowerPick20 Vacuum Gripper or any other gripper, and any other equipment used in the final application) must go through a comprehensive risk assessment process before they can be used.



In order to make the palletizing cell collaborative, several aspects should be taken into consideration. All cells being different, it is important to perform a risk assessment and to enforce the required standards. Please note that the results of the risk assessment depend on the usage and application.

The following non-exhaustive list presents risks that must be assessed during the integration process:

- Risk of load ejection resulting from loss of vacuum.
- Risk of load dropping resulting from loss of vacuum.
- Risk of pinching by any moving component of the Robotiq Palletizing Solution or the robot.
- Risk of damage or breaking if using a custom suction cup bracket that does not meet the technical requirements.
- Risk of damaged objects or injury resulting from a collision between an object and the robot, the gripper or the boxes.
- Risk of injury resulting from a collision between a person and the Solution.



Additional hazards may be present, depending on the configuration and what is being palletized. For instance, the object handled by the gripper could be inherently dangerous to the operator.

To ensure an adequate level of safety, floor markings must be applied to delineate safe zones around the Solution. It is the responsibility of the integrator to establish the proper safe distance from the Solution to protect the user.

	 DANGER
	<p>A collision between a person and the Solution may result in material damage, bodily injury and even death. Make sure anyone working around the Palletizing cell takes all necessary precautions:</p> <ul style="list-style-type: none"> • Before starting the machine, make sure there is enough clearance around the Palletizer and make sure no one is in the work area of the Solution. • During palletization, it is possible to access the cell from all sides. The customer has to assess the risks accordingly.





2.2.2. Emergency Stop

	 WARNING
	<p>There is no emergency stop button directly on the Robotiq Palletizer. The emergency stop button used by the Palletizing Solution is the one found on the robot's teach pendant. Make sure operators know how to stop the Solution in case of emergency.</p>

Depending on the supply source, when the emergency stop (e-Stop) button is pressed, the following consequences may occur. The user has the responsibility to perform a risk assessment and choose the appropriate option.

Supply Source	Behavior
Robot Control Box Supply (any 24 V terminal)	<p>The Vacuum Gripper is powered on.</p> <ul style="list-style-type: none"> An object is detected: the vacuum level will continue to be regulated and the object will not be lost. <p>Note: the PowerPick20 gripper (optional) connects to the robot control box supply.</p>
Robot tool supply (tool connector)	<p>Power failure to the Vacuum Gripper.</p> <ul style="list-style-type: none"> The vacuum level will drop to ambient pressure and the object will be lost. <p>It is not recommended to connect the Vacuum Gripper to the tool connector.</p>

	 CAUTION
	<p>Loss of vacuum can occur due to power failure or air supply interruption.</p>

2.2.3. Noise Level

With the PowerPick20 Gripper operating at the optimal pressure level, the noise level at the workstation is 79 dBA (please refer to the **Specifications** section of the PowerPick20 Vacuum Gripper user manual, available at robotiq.com/support).

Hearing protection is recommended but not mandatory.

Make sure that all local safety measures and regulations are met.

Noise levels should be measured regularly under normal operating conditions.

2.2.4. Cyber Risk



- The customer must provide a safe firewall connection to avoid unauthorized remote control of the robot.
- The customer must set a password to avoid unauthorized access to the robot safety configurations.

2.2.5. Residual Risk



For the intended use of the robot system, measures have been taken to prevent personal injury and property damage. Nevertheless, residual risk remains in certain situations.





Misinstallation

	 WARNING
	<p>Tip Over Hazard</p> <p>Failure to anchor the Solution according to the guidelines found in the Anchoring the Solution section may result in material damage, bodily injury or death.</p>



Improper Moving of the Solution

	 WARNING
	<p>Tip Over Hazard</p> <p>Failure to follow the guidelines found in the Moving and Positioning the Solution section and the Solution Mobility (Wash Down and Production Line Shifts) section</p>

Maintenance and Repair

	 WARNING
	<p>During maintenance and repair work, make sure that the Palletizing Solution is turned off, de-energized and cannot be accidentally turned on again.</p>



- Maintenance and repair work should only be carried by qualified and authorized service personnel.
- After maintenance and repair work, make sure to remove all tools and equipment to prevent ejected or falling parts, material damage or bodily injury.
- All pneumatic tools and devices must be emptied of compressed air before maintenance and repair work.
- All electric tools and devices must be safely isolated before maintenance and repair work.
- Always inform the operator before performing maintenance or repair work. Notify a supervisor and lock out/tag out the machine to prevent users from turning on and using the system. Enforce local safety regulations.
- If necessary, secure the maintenance and repair area with temporary barriers.
- Before performing repair work, clean the affected parts, especially the connections and fittings.
- Install the Solution in a safe position. Depending on the maintenance and repair work to carry out, parts may come loose and cause injury.

	 WARNING
	<ul style="list-style-type: none"> • Maintenance and repair work on electrical equipment must be carried out by qualified and authorized personnel. • Do not bring electrical components into contact with cleaning agents. Electrical components should only be cleaned when the Palletizing Solution is turned off and de-energized.



- After having performed maintenance and repair work, verify screw torque and adjust accordingly if required.
- If the dismantling of safety equipment is necessary before performing maintenance or repair work, the equipment must be reinstalled and assessed immediately after completion of said work.
- Use original spare parts exclusively.
- Perform preventive maintenance and cleaning work at regular intervals according to the **Periodic Inspection and Maintenance** section.

Risk of Accident

	 WARNING
	<p>During maintenance, there is an increased risk of accident due to the parts, tools and equipment used in and around the Palletizing Solution area.</p>

- Slip, trip and fall hazards can be avoided by maintaining order and cleanliness in the workplace.
- For work in elevated positions (500 mm and more), fall protection equipment must be installed and used.
- When dismantling or replacing machine parts in elevated positions (500 mm and more), suitable lifting devices should be used.

Hot Surfaces

The proper use of the Palletizing Solution does not create hot surfaces.

If surfaces get hot, please stop using the Solution and [contact the Robotiq support team](#).

Radiation



The proper use of the Palletizing Solution does not create non-ionizing radiation.

Pneumatic Limitations

- The maximum permissible pressure for all pneumatic components must never be exceeded.
- Pneumatic tubing must be checked at regular intervals and replaced if necessary.
- Leaky connections must be sealed to avoid breakage, unnecessary or excessive noise, loss of energy, etc.

Protective Devices

Manipulating or circumventing protective devices during the operation of the Solution is generally not permitted and should be considered negligent.

	 WARNING
	<p>In the event of incorrectly installed, defective or even missing protective devices, operation of the machine is not permitted.</p>





Electromagnetic Compatibility (EMC)

- Unauthorized changes to electrical components can lead to increased sensitivity to interference, and increased interference emission. As a result, safety components may be impaired.
- Work on electrical equipment must only be carried out by qualified and authorized personnel.
- Be aware of the possible residual energy after turning off an electrical device with large capacitive components

Electrical Energy

- Work on electrical equipment must only be carried out by qualified and authorized personnel.
- Be aware of the possible residual energy after turning off an electrical device with large capacitive components. Wait the appropriate amount of time before working on the device.
- Secure the work area with temporary barriers and a warning note. Secure the main switch with a padlock to prevent unauthorized switching on.
- Use only isolated tools in the corresponding voltage level.
- Use only fuses with specified cut-off current and appropriate dielectric strength.

Robot Risks



	<div style="background-color: #ff8c00; color: white; padding: 5px; text-align: center;">  WARNING </div> <ul style="list-style-type: none"> • All personnel working with and around the robot must be informed of the inherent risks and safety instructions. • To avoid being pinched or crushed when the robot moves toward a stationary object, always keep a minimum distance of 500 mm. • To avoid being pinched or crushed when the robot moves toward the floor, always keep a minimum distance of 300 mm. • To avoid being pinched or crushed between the robot (or gripper) and walls or peripherals, always keep a minimum distance of 500 mm. • Those values aforementioned are taken from standard EN 13854:2019 (Minimum gaps to avoid crushing of parts of the human body). The installation must maintain the minimum distances specified in this standard.
---	---

For more information, refer to the robot's instruction manual.



- Robots move quickly and exert high force. A program interruption or stop can be followed by rapid and dangerous movements.
- Even a programmed robot can be affected by external signals and make unexpected movements. Therefore, when entering the work area, all safety instructions must be observed.
- Robot teaching, robot programming and software modification may only be performed by competent and authorized personnel.
- Changes to the robot's safety settings may only be made by competent and authorized personnel. The changes must be verified and documented.
- Reducing the speed and acceleration of the robot reduces the risks as it:



- Gives the operator more time to react appropriately.
- Reduces the robot's braking time.

	 WARNING
	Reducing the robot's speed does not reduce the risk of pinching or crushing. Even at its slowest speed, the robot movements can cause material damage and bodily injury.



Movement Without Power Supply



	 DANGER
	If a person has been trapped by the robot arm, make sure that attempting to free the person does not aggravate an injury or further increase the risk of injury.

In the case of an undesired event (malfunction, emergency, blockage, etc.), power loss or unwanted power surge, you can:

- Use forced back-driving. To perform forced back-driving, push or pull the robot arm hard enough to move the joint. Each joint brake has a friction clutch that enables movement during high forced torque.

Performing forced back-driving requires high force and cannot be performed by one person alone. In clamping situations, two or more people are required to do the forced back-driving. In some situations, two or more people are required to disassemble the robot arm if necessary.



	 WARNING
	Moving the robot arm manually is intended for urgent/emergency procedures and service purposes only. Do not move the joint more than necessary, not more than 160 degrees, to ensure the robot can find its original physical position.

	 CAUTION
	Attempting to release a joint brake manually may cause material damage and bodily injury.

For more information, refer to the robot's instruction manual.

2.3. Use of the Solution

2.3.1. Intended Use

	 CAUTION
	The emergency stop function is intended for use in emergency conditions and not for stops in normal conditions.



The Robotiq Palletizing Solution is specifically designed for palletization.



Only use the Solution in its original condition without making unauthorized modifications.

Only use the Solution if it is in perfect technical condition.



The Solution is intended to be used with a UR20 robot from Universal Robots.

Always comply with local, state, province and federal laws, regulations and directives, and always operate the Solution in compliance with automation safety and general machine safety guidelines.

Do not use the Solution to handle boxes containing hazardous substances. Should hazardous substances be handled by the Solution, perform a risk assessment that accounts for such substances.

	 CAUTION
	<p>Since there are numerous different materials used in the packaging industry, and since each material has its own characteristics, properties and behavior with vacuum pressure, a thorough risk assessment is in order, regardless of the box/package material.</p>

2.3.2. Misuse

	 WARNING
	<p>The unit should be used exclusively within the range of its technical data. Any other use of the Solution is deemed improper and unintended. Robotiq will not be liable for any damages resulting from any improper or unintended use of the Solution.</p>

Any use of the Solution other than that described in this manual is considered a misuse and should be avoided.

Misuse of the Solution includes but is not limited to the following situations.

Integration misuse:

- Use of the Solution with a robot other than a UR20.
- Use of a payload higher than the robot's maximum payload.
- Use of the Solution outside of the environmental and operating conditions.

Operational misuse:

- Standing on the pallet.
- Operation of the Solution by inexperienced or untrained staff members.
- Manual placing or adjustment of a box on the pallet while the Solution is in operation.

2.3.3. Final Application

Expected System Behavior in Normal Operating Conditions

	NOTICE
	Various types of external safety devices can interface with the Robotiq Palletizing Solution to ensure a safe operation.

	NOTICE
	<ul style="list-style-type: none"> • Category 0 Stop: Stops the Solution by immediate removal of power. • Category 1 Stop: A controlled stop of the Solution. Power is removed when the stop is achieved. • Category 2 Stop: A controlled stop of the Solution. Power is still available once the stop is achieved. <p>Please refer to IEC 60204-1 for additional information on stop categories.</p>

- **Normal mode:** The palletizer continuously fills pallets when no human operator is in the vicinity of the palletizing cell.
- **Safeguarded operation**
 - **Reduced mode:** The palletizer continuously fills pallets, even when an operator enters the palletizing cell. The operator can safely remove a filled pallet or place a pallet in an empty slot. The system will not start to palletize on an empty pallet unless the operator has pressed the “Confirm pallet(s) ready” button. To obtain this behavior, the “Confirm pallet(s) ready” checkbox in the Installation tab must be ticked. Also, to allow cell access to the operator, a complete risk assessment must be performed, and additional parameters must be set (which include, but are not limited to: robot speed, robot force, safety planes, guardrails).
 - **Separation monitoring mode:** The system stops when a human operator enters the vicinity of the palletizing cell to manipulate a filled pallet, place a pallet in an empty pallet slot, troubleshoot the system or any other operation requiring human intervention. In such a state the robot will maintain a Category 2 stop. When the safeguards are removed, the system resumes operation in Normal mode.

The system enters emergency stop mode when the emergency stop button is pressed.



The following table indicates which stop category corresponds to each operation mode.

Operation mode	Robot		
	Force (N)	Power (W)	Speed (mm/s)
Normal mode (Up to safety limits)	Up to 250	Up to 1,000	Up to 10,000
Protective stop	Category 2 Stop		
Safeguard stop	Category 2 Stop		
Emergency stop	Category 1 Stop		
Reduced mode	Please refer to the Universal Robots user manual for more details.		

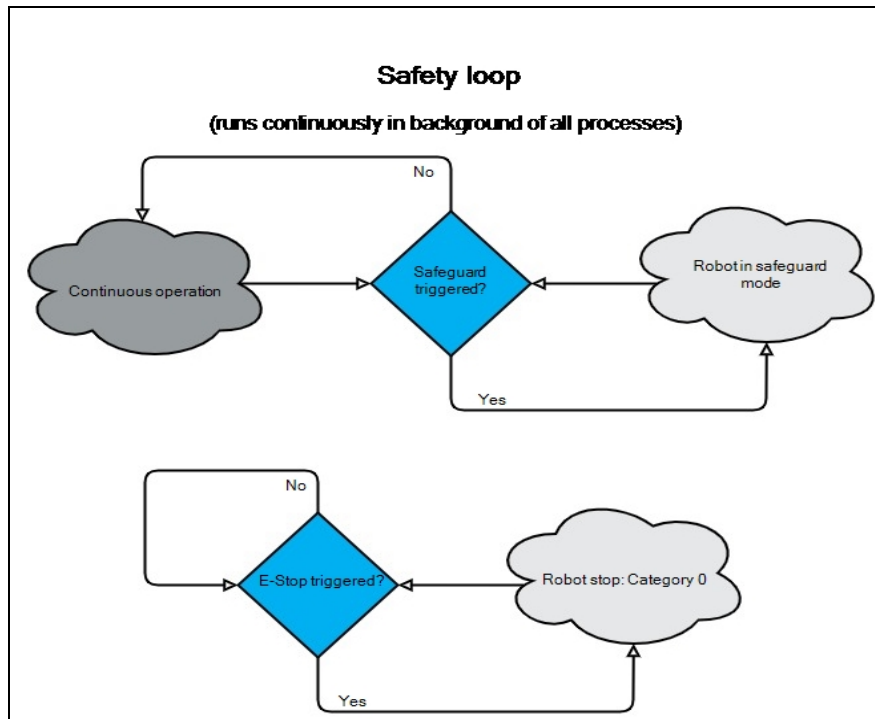

Fig. 2-1: Safety Logic Diagram

	 WARNING
	After a collision or an emergency stop, an inspection of the Solution must be performed before resuming the use of the machine. Special attention must be given to the pedestal, the cable management system, and the gripper components. Please contact support@robotiq.com if any sign of damage is detected.



Stopping Times of the Safety System

The stopping time related to the Solution's safety system corresponds to the stopping time of the robot.

Please refer to the UR20 user manual on the Universal Robots website to calculate the stopping time based on the application.

If safety devices and safety relays are part of the palletizing cell, the stopping times of such devices must be accounted for (i.e., added to robot's stopping time).



3. Installation

This section will guide you through the installation and general setup of the Robotiq Palletizing Solution.

Before installing:

- Read and understand the safety instructions related to the Palletizing Solution. Refer to the **Safety** section.
- Verify the package according to the scope of delivery and the order.
- Make sure to have the required parts, equipment and tools listed in the scope of delivery.
- Make sure to meet the recommended environmental conditions.



NOTICE

Robotiq uses the metric system. Unless otherwise specified, **all dimensions in this manual are in millimeters.**



WARNING

- Do not turn on or operate the Palletizing Solution before making sure the device is firmly anchored and the machine area is cleared.
- When assembling or moving the Solution, make sure there is enough vertical and horizontal clearance in order to avoid material damage and bodily injury.
- Make sure that the air supply source is secured.
- Failure to properly secure and install the equipment can result in material damage and bodily injury.
- If the installation is not performed in compliance with the manufacturer's instructions, the warranty will be void.

- Make sure to follow all workplace safety rules and regulations when installing, operating, servicing, inspecting and maintaining the Robotiq Palletizing Solution.
- Always wear all recommended personal protective equipment in accordance with the safety standards of the workplace, including but not limited to:
 - Safety glasses
 - Hearing protection
 - Hard hats
 - Steel-toe boots
- Always use proper safety measures when working with tools that have sharp edges, pinching surfaces, or heat sources.
- Always lift heavy objects with the legs, not the back. Ask for help or find alternative solutions if a heavy object cannot be lifted by a single person.



3.1. Scope of Delivery

- 1 x PE20 Palletizing Solution base kit including:
 - 1 x PE20 base
 - 2 x Photoelectric pallet sensors
 - 1 x Robotiq control box
 - 1 x Support bracket for UR control box
- 1 x PE20 removable stopper for Palletizing Solution
- 1 x PE20 Palletizing Solution pedestal
- 1 x PE Series Palletizing Solution operator station:
 - 2 x Status lights
 - 1 x Teach pendant rack
 - 1 x Push button enclosure
- 1 x Box detection sensor kit:
 - 1 x Box detection sensor
 - 1 x Box sensor bracket with screws
 - 1 x 5 m box sensor cable
- 1 x Robot cable management kit:
 - 3 x 500 mm cable clip
 - 1 x 1000 mm cable clip
 - 6 x 190 mm cable tie
- 1 x Material Handling Copilot software license dongle
- 1 x Installation hardware kit:
 - 6 x M10 x 30 mm socket head cap screws with serrated Belleville washers
 - 4 x M8 x 20 mm hex serrated head flange screws
 - 8 x M12 x 30 mm hex serrated head flange screws
 - 1 x Single use, medium strength threadlocker
 - 7 x 1/2 in x 3-3/4 in Concrete wedge anchors with serrated flange nuts
 - 8 x Shim washers (included but optional)
 - 12 x 190 mm cable ties
 - 2 x 360 mm cable ties
 - 1x Pneumatic adapter 1/2 BSPP (1/2 G) to 1/2 NPT (included but optional)



- 1 x 4-port USB hub
- 1 x USB-to-Ethernet adapter
- 1 x Installation tool kit:
 - 1 x 1/2 in x 6 in concrete drill bit
 - 1 x 13 mm socket, 3/8 in square drive
 - 1 x 16 mm socket, 3/8 in square drive
 - 1 x 17 mm socket, 3/8 in square drive
 - 1 x 3/4 in socket, 3/8 in square drive
 - 1 x 8 mm hex bit socket, 3/8 in square drive
 - 1 x 10 mm hex key, L-shape
 - 1 x 5 mm hex key, L-shape
 - 1 x 2 mm hex key, L-shape
 - 1 x 8 mm / 10 mm double-ended wrench
 - 1 x 2.4 mm flat screwdriver
- 1 x PowerPick20 Vacuum Gripper standard kit (optional):
 - 1 x PowerPick20 vacuum generation unit
 - 1 x Mounting bracket and filter-regulator assembly
 - 1 x M12-12 pin I/O cable
 - 1 x Powerpick20 Vacuum Gripper, default configuration
 - 1 x Large suction cup bracket assembly
 - Air tubing
 - Tools and hardware for installation on PE20

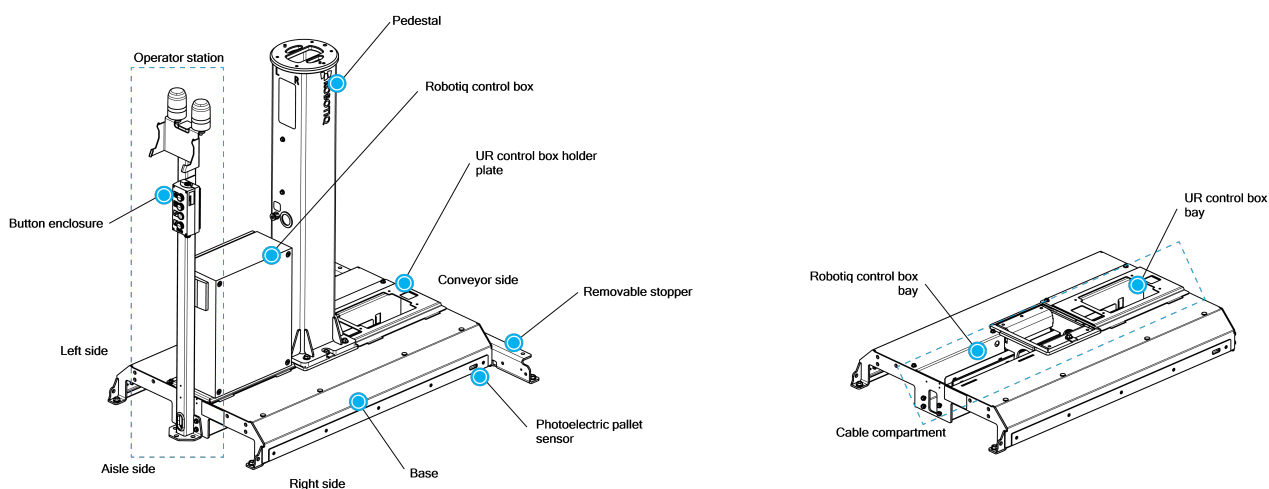

Fig. 3-1: Components of the Robotiq PE20 Palletizing Solution



3.2. Required Tools and Equipment

The following tools are required to install the Palletizing solution.

Included:

- 1 x 1/2 in x 6 in concrete drill bit
- 1 x 13 mm socket, 3/8 in square drive
- 1 x 16 mm socket, 3/8 in square drive
- 1 x 17 mm socket, 3/8 in square drive
- 1 x 3/4 in socket, 3/8 in square drive
- 1 x 8 mm hex bit socket, 3/8 in square drive
- 1 x 10 mm hex key, L-shape
- 1 x 5 mm hex key, L-shape
- 1 x 2 mm hex key, L-shape
- 1 x 8 mm / 10 mm double-ended wrench
- 1 x 2.4 mm flat screwdriver

Included with PowerPick20 (Optional)

- 1 x 6 mm hex key, L-shape
- 1 x 21 mm / 24 mm double-ended wrench

Not included:

- Forklift or pallet jack (minimum fork length of 1065 mm [42 in])
- Hoisting equipment (minimum payload capacity of 200 kg [440 lb])
- 2 x Twisted eye web sling (minimum payload capacity of 100 kg [220 lb])
- Power screwdriver
- #2 Phillips bit (or #2 Robertson bit)
- Utility knife
- 3/8 in drive ratcheting socket wrench or adapter
- 3/8 in drive torque wrench or adapter with minimum torque range of 15 - 84 Nm (11 - 62 lb-ft)
- Rotary hammer drill
- Hammer



3.3. Environmental and Operating Conditions

Attribute	Value
Minimum storage/transit temperature	-20 °C [-4 °F]
Maximum storage/transit temperature	60 °C [140 °F]
Minimum operating temperature	0 °C [32 °F]
Maximum operating temperature	50 °C [122 °F] ¹
Humidity (non-condensing)	Palletizing solution: 20-90% RH PowerPick20 Gripper: 35-85% RH
Food / Clean room / Intrinsic Safety (IS)	Not compatible
Dust and water	<ul style="list-style-type: none"> • Dust: Affect maintenance intervals • Water: Not compatible
Other	<ul style="list-style-type: none"> • Free from corrosive liquids or gases • Free from explosive liquids or gases

¹ Speed values might be derated at temperatures above 35 °C (95 °F).

Table 3-1: Environmental and operating conditions of the Robotiq Palletizing Solution



CAUTION

Use of the Robotiq Palletizing Solution is not recommended in presence of chemicals.



3.3.1. Air Supply: Compressed Air Supply System to PowerPick20 Vacuum Generation Unit

Compressed air must be supplied to the PowerPick20 vacuum generation unit (and in turn to the Vacuum Gripper) according to the technical specifications.

For maintenance and other purposes, it is recommended to install a lockout valve before connecting the product.

The air supply tubing must be connected and disconnected to or from, the inlet port of the PowerPick20 vacuum generation unit, only when the line is depressurized.



When the line is pressurized, the air supply tubing must be securely connected to **Port P+** of the the PowerPick20 vacuum generation unit.

Air supply can be routed through the base and secured to the pedestal. Please refer to the **Mounting and Installation** section and to the **Pneumatic Diagram** section.

3.3.2. Depressurizing the Supply Line

In order to safely depressurize the supply line, the air supply must first be shut off. If no lockout valve is present to depressurize the line, activate the vacuum Gripper to release the pressure.

3.4. Mounting and Installation

	 WARNING
	<ul style="list-style-type: none"> • DO NOT install this equipment without having read and understood the Robotiq PE20 User Manual. • DO NOT install this equipment without having the proper training and experience. • DO NOT install any robot other than the Universal Robots UR20. <p>Failure to follow these instructions and to properly secure or install the equipment can result in material damage, death or serious injury. The warranty will not cover material damage resulting from an installation that does not comply with the instructions found in this manual.</p> <p>Make sure to follow all safety rules and regulations of the workplace. Always wear all recommended personal protective equipment in accordance with workplace safety standards.</p>

3.4.1. Visual Inspection

The Robotiq Palletizing Solution is shipped on a pallet. A wooden crate protects the hardware from external elements.



The wooden crate containing the Robotiq Palletizing Solution weighs 230 kg (506 lb). A forklift truck or pallet truck is therefore necessary to move it. The operation of such machinery should be done by qualified and authorized personnel.

Before disassembling the crate, inspect it to make sure there is no damage or defect. If damage or defects are observed, contact the [Robotiq support team](#).



3.4.2. Unboxing

A minimum of two people is recommended to perform the following steps.

	 WARNING
<p>The transport, lifting, and moving of the Robotiq Palletizing Solution should be performed by qualified and authorized personnel. Failure to do so may result in material damage, bodily injury or death.</p>	

1. Remove the top panel and the four (4) sides of the crate by removing the screws that hold them into place.

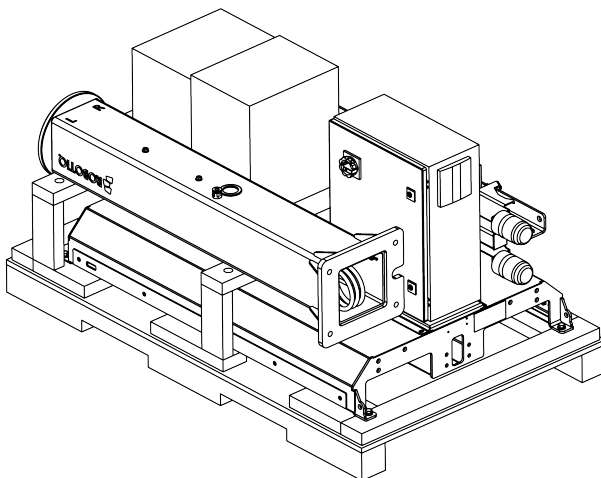



2. Remove the cardboard box (or boxes) from the shipping crate and open the box containing the accessory kit.

The tools, fasteners and hardware needed for the rest of the installation are located inside the cardboard box with the Installation Guide attached to it.

If the order includes a PowerPick20 gripper, it will be packaged in an additional cardboard box.

3. Cut and remove the strapping material.
4. Remove the operator station and removable stopper from the crate.
5. Before removing the pedestal from the shipping crate, use it to measure the cable length needed to reach the robot arm on one end, and the UR control box on the other end.
 - a. Bundle the cable as shown in the figure below. Make sure to leave approximately 150 mm (6 in) of cable on the top side and approximately 700 mm (28 in) on the bottom side.

	 CAUTION
<p>Do not insert the cable in the pedestal.</p>	



- b. Temporarily secure the cable by attaching it to the pedestal using a long zip tie.

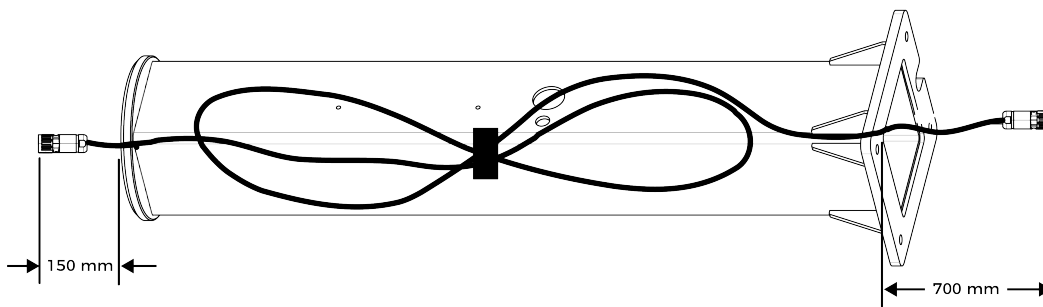

6. Use a 17 mm wrench to remove the lag bolt securing the top plate of the pedestal.
7. Remove the pedestal from the crate.



NOTICE

It is recommended to use proper hoisting equipment to perform this operation.

8. Place the pedestal on a piece of cardboard to prevent damaging the unit.



CAUTION

Make sure that the pneumatic tube and the ground cable located inside the base of the pedestal are not pinched during this operation.



CAUTION

The weight of the pedestal is approximately 54 kg (119 lb). Proceed with caution.

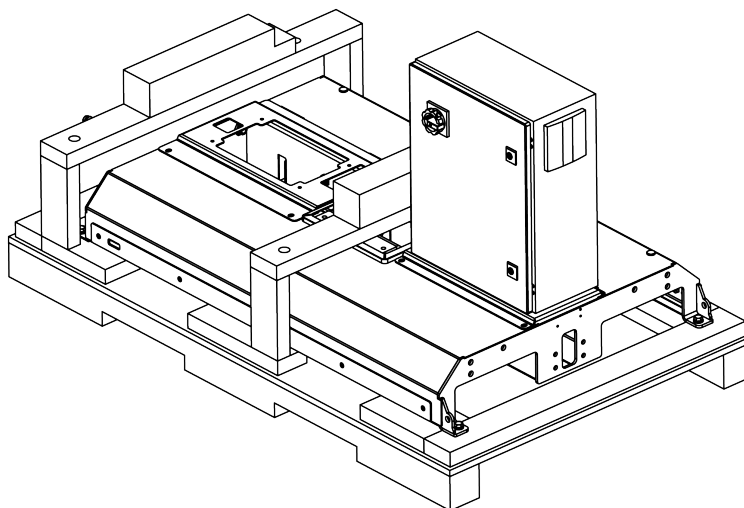

9. Remove the screws that hold the wooden frames to the crate.
10. Remove the wooden frames.



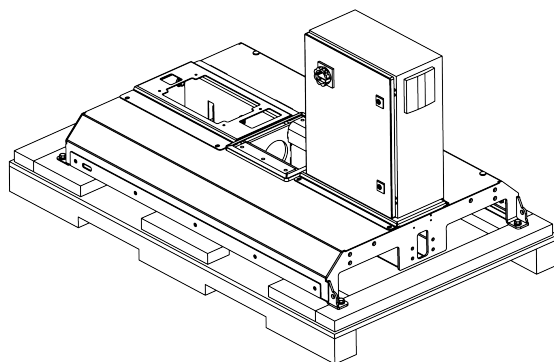

11. Use a 17 mm wrench to remove the four (4) lag bolts that hold the base of the Solution to the bottom of the crate.
12. Use a forklift to lift the base from the aisle side (i.e., the side where the Robotiq control box is located).
13. Place the solution on shims with a thickness of at least 10 mm (3/8 in).



CAUTION

Make sure that the shims are not beneath the two L-shaped aluminum brackets located at the conveyor side of the base.

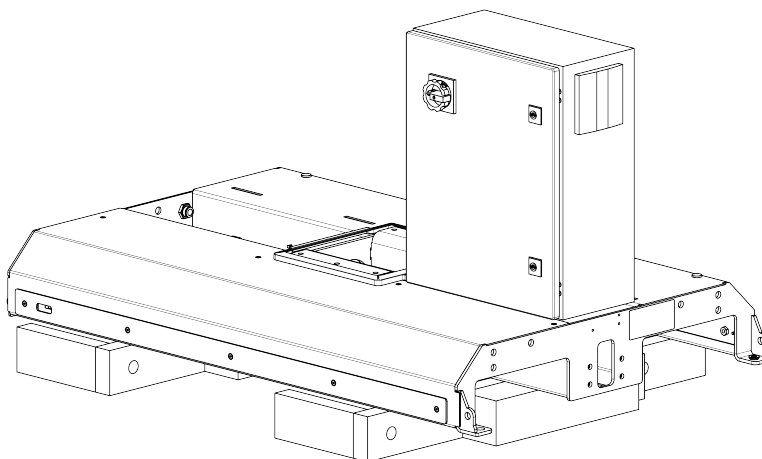

CAUTION

The weight of the base is approximately 82 kg (180 lb). Proceed with caution.



NOTICE

The two (2) wooden frames can be used as shims for this step.

14. Remove the two (2) L-shaped aluminum brackets using a 16 mm wrench.



NOTICE

Make sure to have all components in hand before discarding the shipping crate and packaging



3.4.3. Mechanical and Electrical Installation

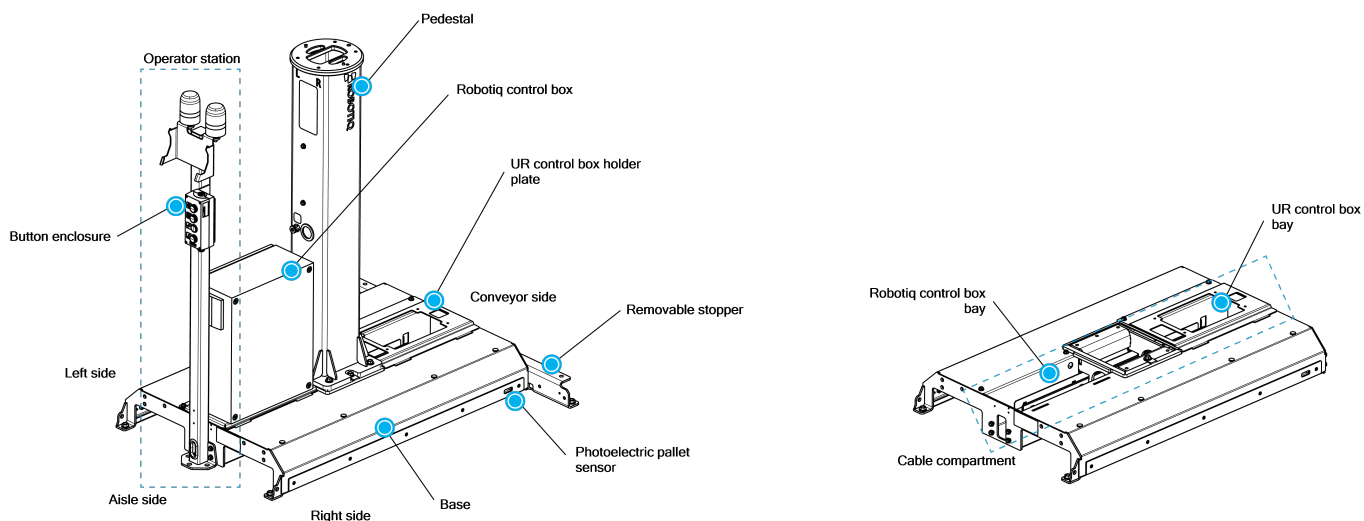

Pedestal Installation



NOTICE

Make sure the base of the Solution is sitting on shims before performing the following steps.

1. Screw the removable stopper to the base of the Solution using the four (4) M12 x 30 hex cap screws. Do not fully tighten the screws.



NOTICE

Should the removable stopper need to be removed in the future (i.e., for transportation or operation of the Solution), do not seal the fastener assembly using thread locking compounds.

Oppositely, in the case of a permanent assembly, consider using thread locking compounds.

Please refer to **Solution Mobility (Wash Down and Production Line Shifts)** section for more information.

2. Use a forklift truck or pallet truck to lift the base and remove the shims underneath it.
3. Place the base directly on the ground.



CAUTION

The combined weight of the base and removable stopper is approximately 92 kg (202 lb). Proceed with caution.



4. Fully tighten the four (4) M12 x 30 hex cap screws to a torque of 84 Nm (62 lb-ft), making sure the tabs are in contact with the base, as shown in the figure below.

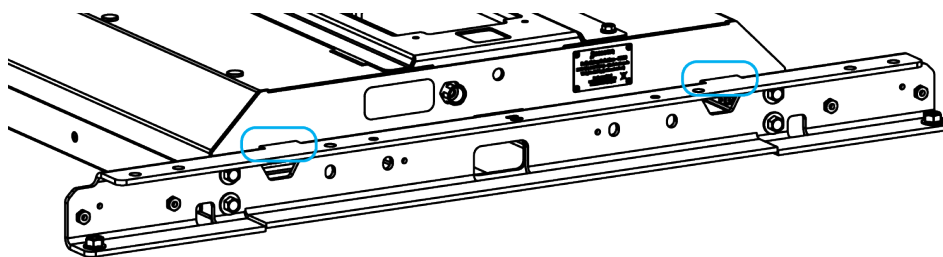

5. Run a sling through the openings on the flange of the pedestal, as shown in the figure below.



6. Using hoisting equipment, lift the pedestal vertically so that it stands above the base.
7. Carefully align the notch in the pedestal base plate with the hex cap screw already installed on the base.



CAUTION

Make sure that the cables located inside the base of the pedestal are not pinched during this operation.



CAUTION

The weight of the pedestal is approximately 54 kg (119 lb). Proceed with caution.

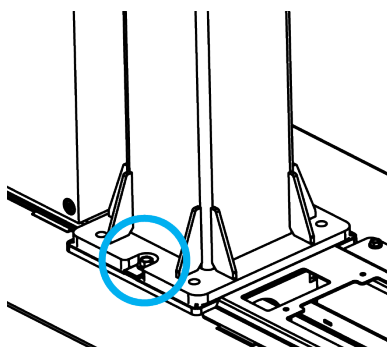

- Secure the pedestal to the base using the four (4) M12 x 30 screws provided. Tighten to a torque of 84 Nm (62 lb-ft).

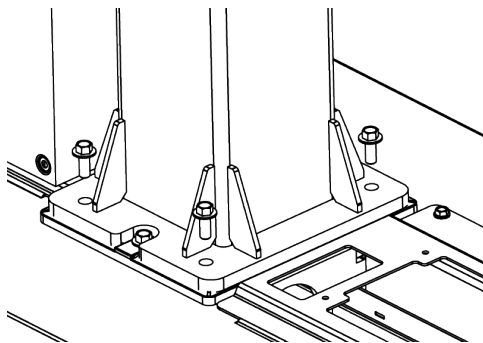

Robot Installation



NOTICE

A minimum of two people is recommended to execute these steps.

- Slide the bundled cable inside the pedestal (see **Unboxing** section).
- From the outside, attach the wrapped cable to the flange of the pedestal using a long cable tie.

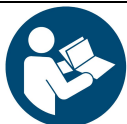
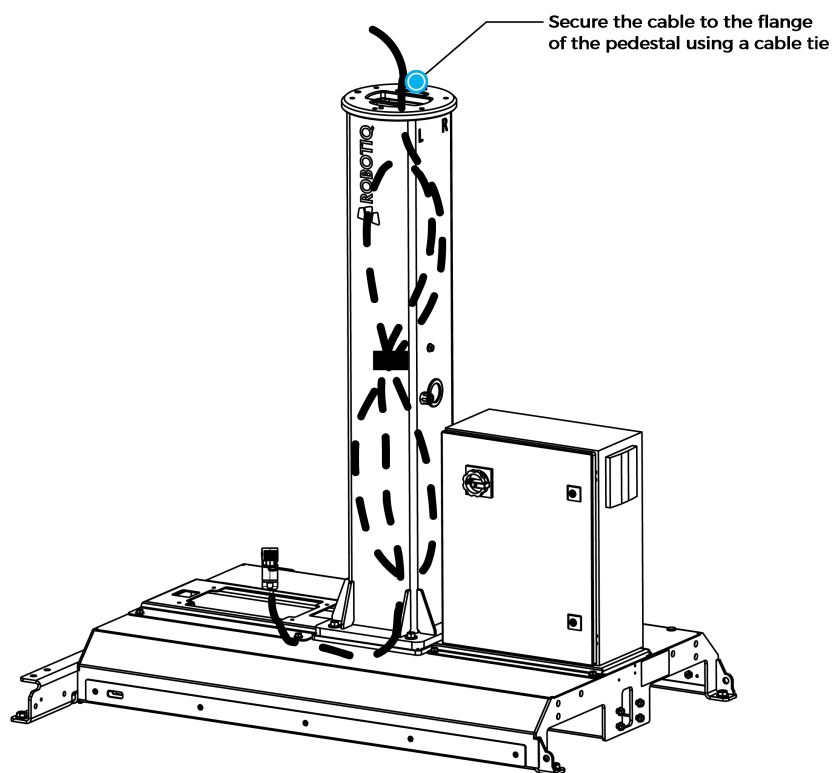

NOTICE

Follow UR guidelines to remove the robot from its packaging and to install the robot on the pedestal.

- Use the rubber plug found in the robot box to close off the hole commonly used to run the robot pigtail cable through the robot base.
- Lift the robot and move it above the pedestal using proper hoisting equipment.



5. Connect the robot to the cable before fully seating it on the flange of the pedestal.
6. Use the two (2) dowel pins to position the robot so that the hole that was previously plugged is oriented towards the “L” and “R” decals on the pedestal (aisle side).

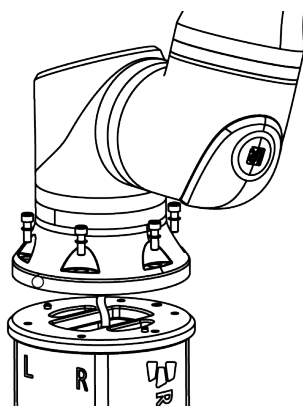

7. Secure the robot base using the six (6) M10 x 30 screws and the six (6) serrated Belleville washers; tighten to the torque specified by UR (please refer to the UR20 user manual).



CAUTION

Make sure that the convex part of the washer is at the bolt end of the assembly.

Control Box Installation

1. Use a 5 mm hex key to remove the four (4) screws securing the two (2) legs of the UR control box.

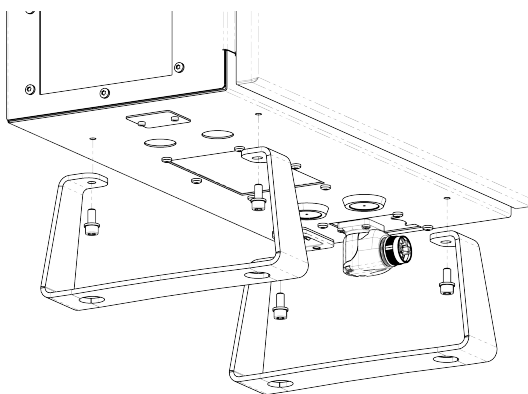

2. Disconnect the UR teach pendant connector and remove it from the UR control box.



NOTICE

Follow the instructions for the replacement of the teach pendant in the service manual of the UR20.

3. Remove the two (2) M8 x 20 hex cap screws securing the control box support plate to the base of the Solution using the 13 mm socket supplied.



- Remove the plate from the base by opening and closing it while lifting.

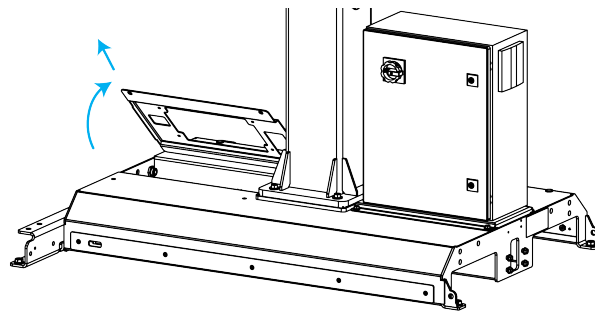

- Fasten the UR control box to the control box support plate using the four (4) screws that were previously removed.



NOTICE

Make sure that the cabinet door is on the side opposite to the retaining tabs.

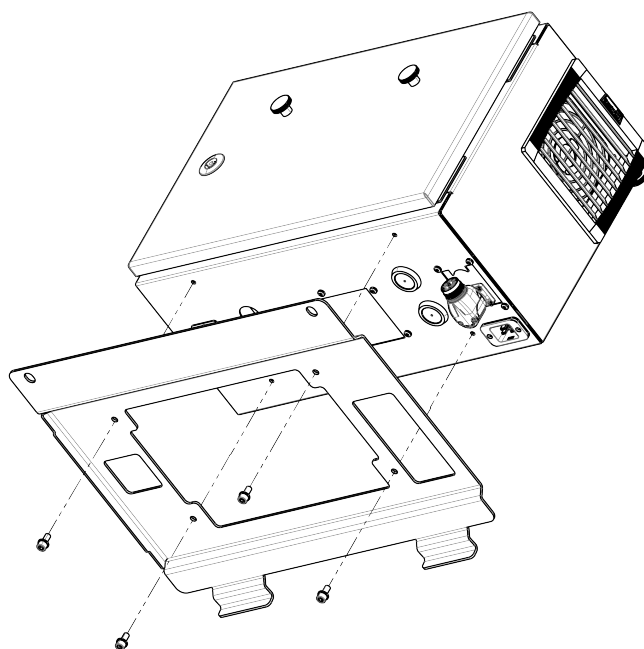

- Secure the assembly to the base by inserting the retaining tabs in their respective cutouts.
- Tilt the control box back and forth to reassemble the hinging mechanism.

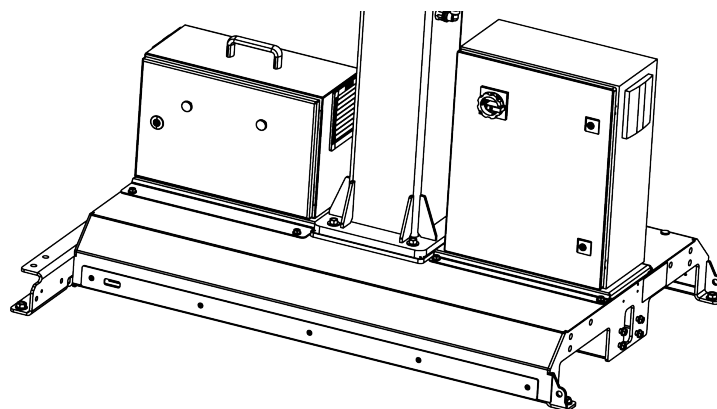

Pneumatic Tubing Installation

1. Remove the two (2) M8 x 20 hex cap screws of the Robotiq control box holder plate.
2. Tilt back the Robotiq control box and the UR control box.
3. Take the 12 mm pneumatic tubing out of the base of the pedestal.
4. Connect the free end of the pneumatic cable to the push-to-connect bulkhead inside the base on the conveyor side.
5. Using cable ties, secure the pneumatic cable to the cable tie mounts of the cable duct.

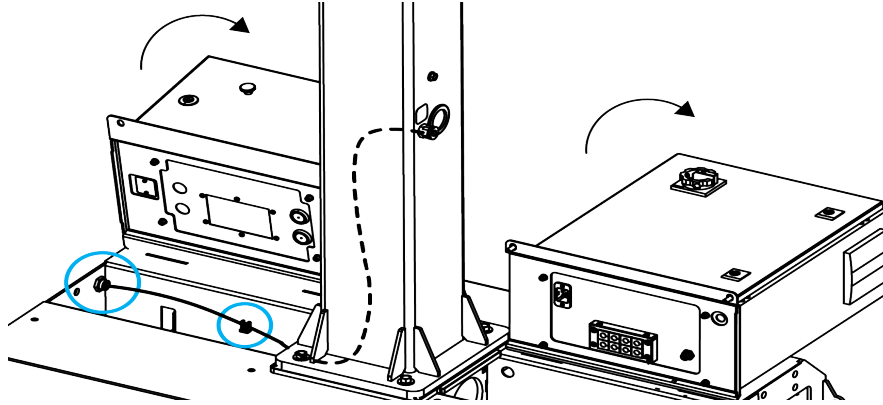

Grounding

Three (3) components should be grounded: 1) the Robotiq control box, 2) the pedestal, and 3) the operator station.

Upon delivery, the ground wire of the Robotiq control box is already connected at both ends, the ground wire of the pedestal is only connected at one end (i.e., to the ground stud inside the pedestal), and the ground wire of the operator station is also only connected at one end (i.e., to the ground stud inside the base of the palletizer).

Robotiq Control Box

The Robotiq Control Box is already grounded. When grounding the other components, make sure that the eyelet connector of the control box's ground wire remains in place.

Pedestal

1. Using a 10 mm wrench, remove the M6 nut and the top lock washer from the main ground stud inside the Robotiq control box bay.
2. Take the ground wire (green) out of the pedestal base.
3. Slide the eyelet connector of the pedestal's ground wire on the ground stud and reinstall the lock washer and M6 nut.
4. Make sure that the eyelet connectors of all three (3) components are on the ground stud, in between the two lock washers.
5. Tighten the M6 nut to a torque of 5 Nm (3.7 lb-ft).



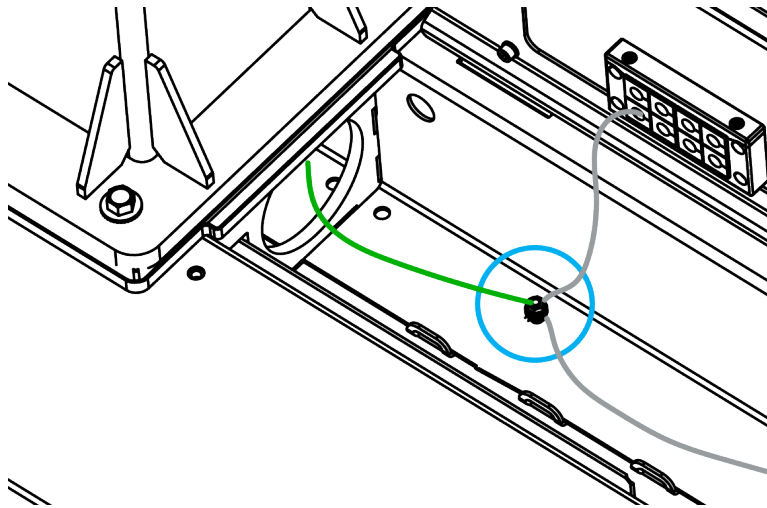

PE20 Operator Station

1. Route the third ground wire to the base of the operator station post.
2. Using a 10 mm wrench, remove the M6 nut and one (1) lock washer from the ground stud inside the base of the operator station post.
3. Slide the eyelet connector of the third ground wire on the ground stud inside the base of the operator station post.
4. Reinstall the lock washer and the M6 nut.
5. Tighten the M6 nut to a torque of 5 Nm (3.7 lb-ft).

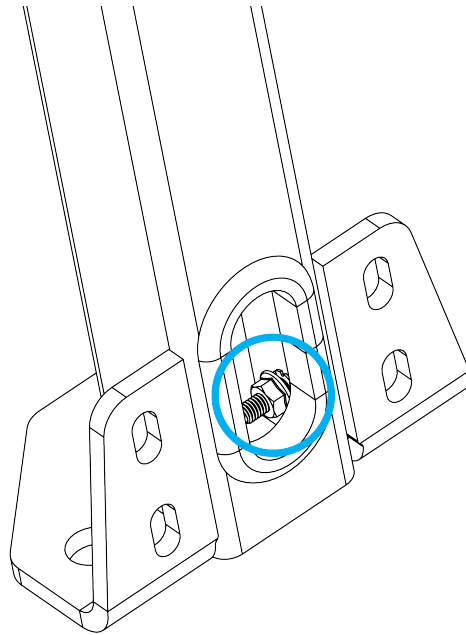
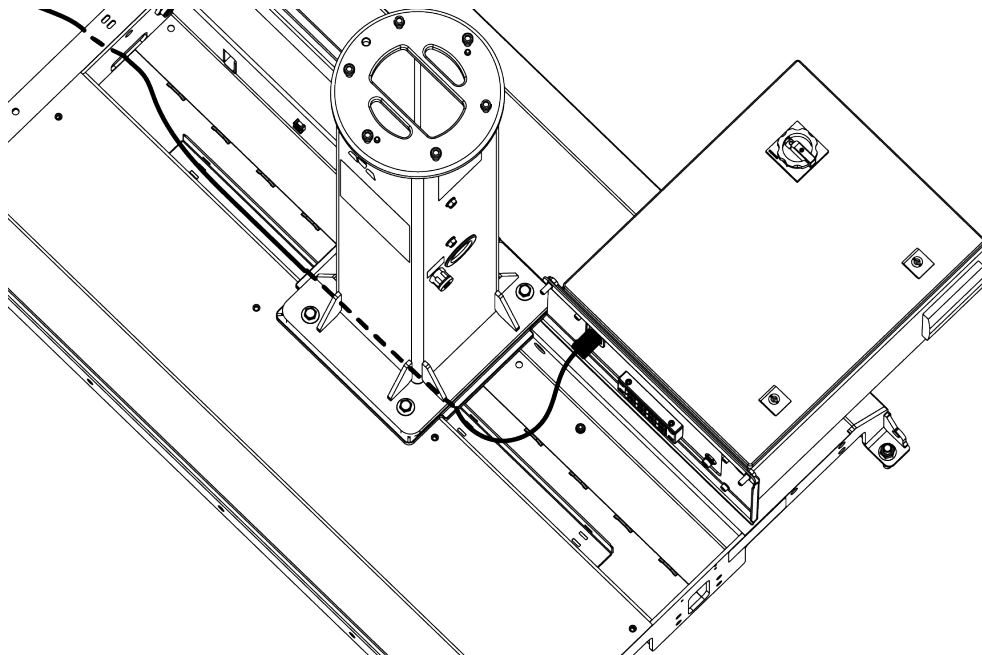

Fig. 3-2: Ground stud in the base of the operator station.

Power and Control Connections

1. Run the power cable provided with the robot through the hole on the conveyor side of the base.
2. Make the cable run along the smaller cable gutter.
3. Connect the cable to the power entry connector of the **Robotiq control box**.
4. Secure the cable to the cable gutter using cable ties.



NOTICE

The robot's power cable and the power cable coming from the Robotiq control box should both be channeled through the cable gutter.

All other cables should be laid directly on the bottom of the bigger cable duct.



WARNING

Electrical Hazard

The power supply cable should be protected in such a way that prevents any risk of pinching, cutting or otherwise damaging the sheathing or sleeve of the cable.

Failure to follow these instructions may result in material damage, serious injury or death.

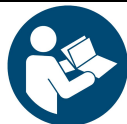

NOTICE

The Robotiq control box provides power to the UR control box.



5. Connect the female power plug from the UR control box bay to the power entry connector of the UR control box.
6. Connect the robot cable tucked into the pedestal to the UR control box.
7. Open the UR control box.
8. Connect the provided USB-to-Ethernet adapter directly to a USB port of the UR control box.
9. Run the W200 Ethernet cable from the UR control box bay to the UR control box.
10. Connect the W200 Ethernet cable to the USB / Ethernet adapter.
11. Run the W103 cable from the Robotiq control box to the UR control box.
12. Wire the W103 cable in the UR control box based on the figure below.

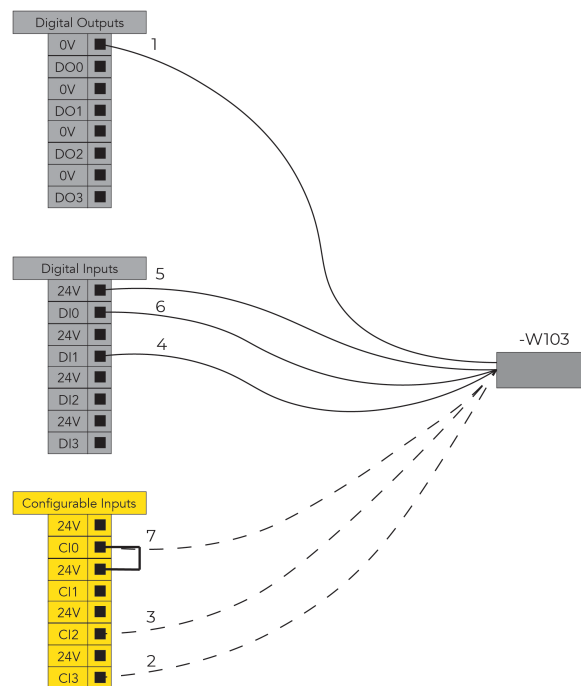

Wire #	Function	Description
1	0 VDC	0 VDC supply
2	Automatic mode safeguard stop #1 input	Emits a safeguard status signal when a safeguard signal is applied to CI3. To be connected only when multiple safety devices are used.
3	Automatic mode safeguard stop #2 input	Emits a safeguard status signal when a safeguard signal is applied to CI2. To be connected only when multiple safety devices are used.
4	Stop button input	Emits a stop signal from the stop button in the push button enclosure. Connected to a digital input (DI1 in the example).
5	24 VDC	24 VDC supply
6	Start button input	Emits a start signal from the start button in the push button enclosure. Connected to a digital input (DI0 in the example).
7	Safeguard reset input	Emits a safeguard reset signal from the safeguard reset button in the push button enclosure. Connected to a configurable input (CI0 in the example). To be connected only when one safety device is used.

13. Run the box sensor cables through the opening located on the conveyor side of the Solution, and to the UR Control box.
14. Wire the cables based on the configuration of the palletizing cell (Single Box Type or Multiple Box Types / Multi-Pick Feature).
15. Connect the provided USB hub to the second USB port.
16. Connect the Copilot license dongle to one of the ports of the USB hub.
17. Bring the operator station near the base of the Solution, on the aisle side.
18. Run the teach pendant cable through the opening on the lower section of the operator station, and through the base.
19. Connect the teach pendant cable to the teach pendant connector of the UR control box.



NOTICE

The operator station can either be attached to the base of the Palletizing Solution or anchored to the ground.

Please refer to the **PE20 Operator Station Installation** section for more information.





CAUTION

- To attach the operator station to the base, run the teach pendant cable through the opening on the lower section of the operator station before leading the cable in the base.
- To install the operator station remotely, **do not** route the teach pendant cable through the opening on the lower section of the operator station. Instead route it directly through the base opening on the aisle side.

20. Run the W102 cable from the operator station to the base.

21. Connect the W102 cable to the W100 cable.



NOTICE

An optional extension cable (W101) can be used to displace the operator station.

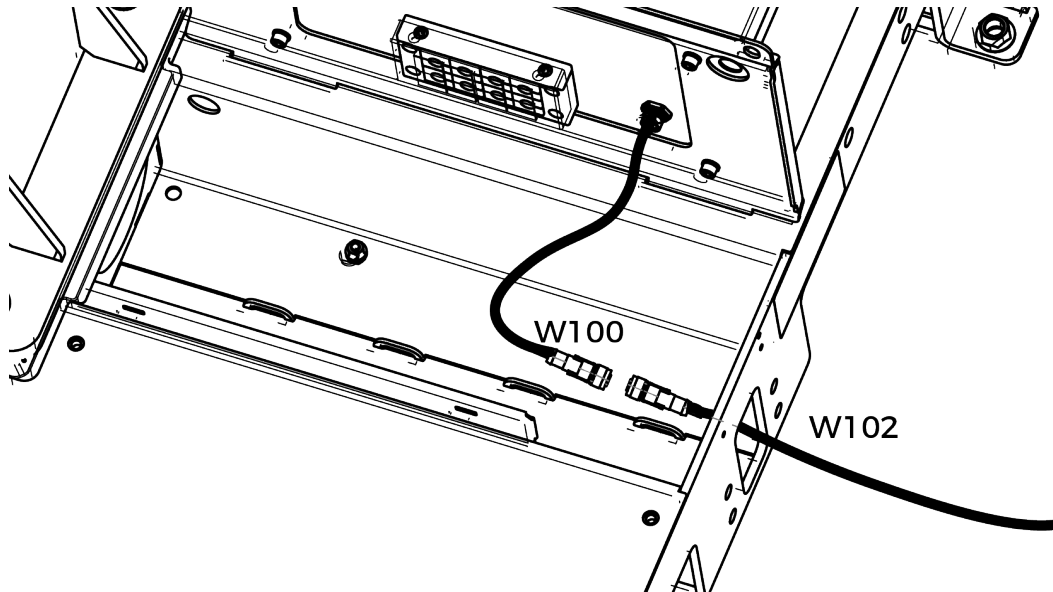

NOTICE

The optional safety kit requires the interfacing of a reset push button.

If there is no optional safety kit in the scope of delivery, the hole left by the optional reset push button is filled with material.

22. Run the W72 and W82 cables from the operator station to the base.

23. Connect the W72 cable to the W70 cable.

24. Connect the W82 cable to the W80 cable.



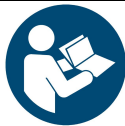

NOTICE

Optional extension cables (W71 and W81) can be used to displace the operator station.

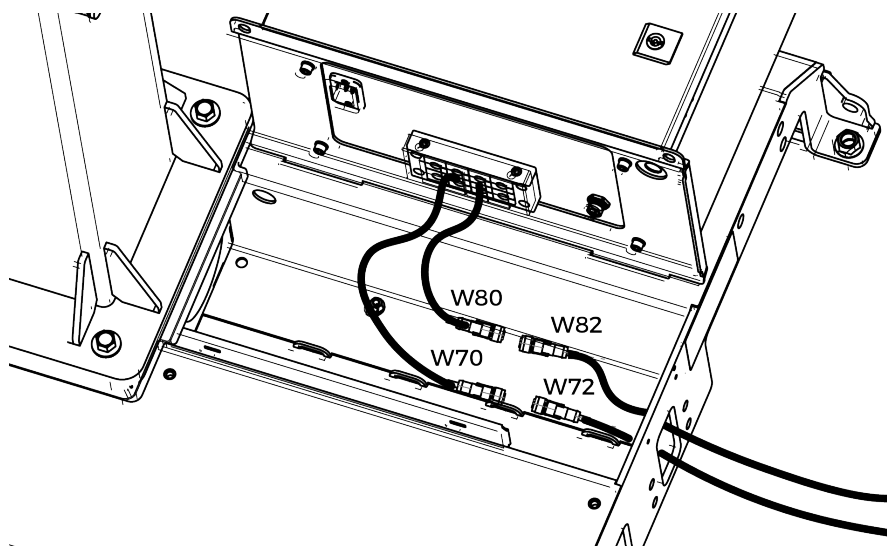

25. When all cables are routed inside the cable duct, secure them to mounting points using cable ties.
26. Put both control boxes back in place by tilting them forward.
27. Secure the support plate of each control box using four (4) M8 x 20 hex cap screws.

PE20 Operator Station Installation

By default, the operator station (i.e., the post holding the teach pendant rack and push button enclosure) is designed to be attached to the base of the palletizing solution or anchored to the ground. If the solution needs to be moved frequently, the operator station needs to be located accordingly.

As an example, if the operator station is anchored too close to the solution, but not directly installed on the base, there must be sufficient space left to access the solution using a pallet truck or forklift.

If the operator station needs to be located further away from the solution, cable extensions kits are available as an option. Please contact support@robotiq.com to add them to the scope of delivery.

- If the operator station needs to be attached to the base, fasten the post to the base on the aisle side with four (4) M8 x 20 mm screws, using a 13 mm wrench. Tighten to 25 Nm (37 lb-ft). Tuck the excess cable inside the base through the opening.
- If the operator station needs to be anchored to the ground, use the three (3) provided concrete wedge anchors. Please refer to the **Anchoring the Solution** section for more information on how to install the wedge anchors. Tighten the nut of each anchor to 70 Nm (52 lb-ft).



Centering the Solution

This procedure needs to be performed before installing the vacuum gripper. It will ensure the proper functioning of the Solution. The goal is to properly align the column with the base by placing the robot wrist at a specific position when the latter is in contact with the side of the base.

1. Connect the power supply cable to a power outlet.
2. Power on the robot.
3. Loosen the four (4) screws that secure the column to the base. Unscrewing the screws half a turn counterclockwise should provide enough clearance to allow for the adjustment of the column's orientation.



WARNING

Do not completely remove the screws. (i.e., do not unscrew more than half a turn). Doing so can cause the column to tip over and, in turn, result in bodily injury and material damage.

4. Rotate the column counterclockwise as much as possible.

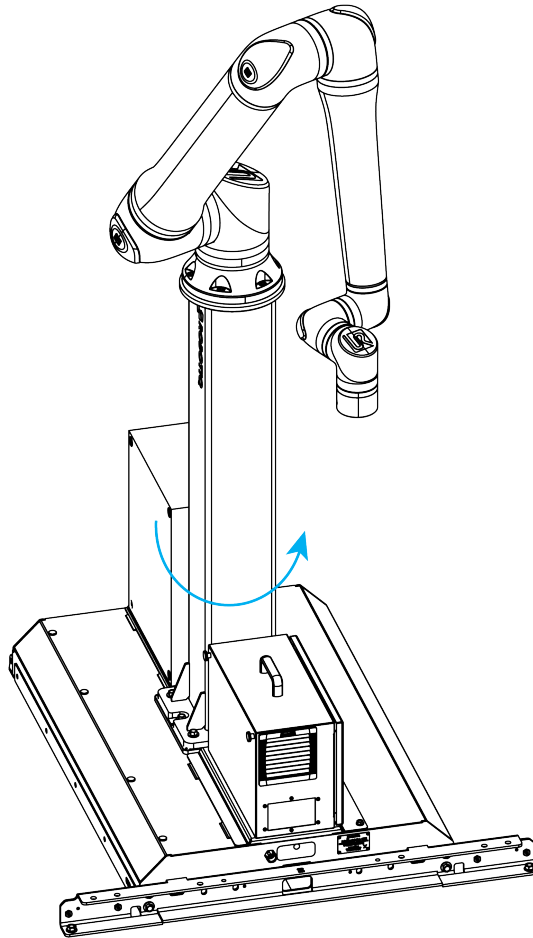

5. Position the robot so that the wrist is on the outer left side of the base, as shown in the figure below.



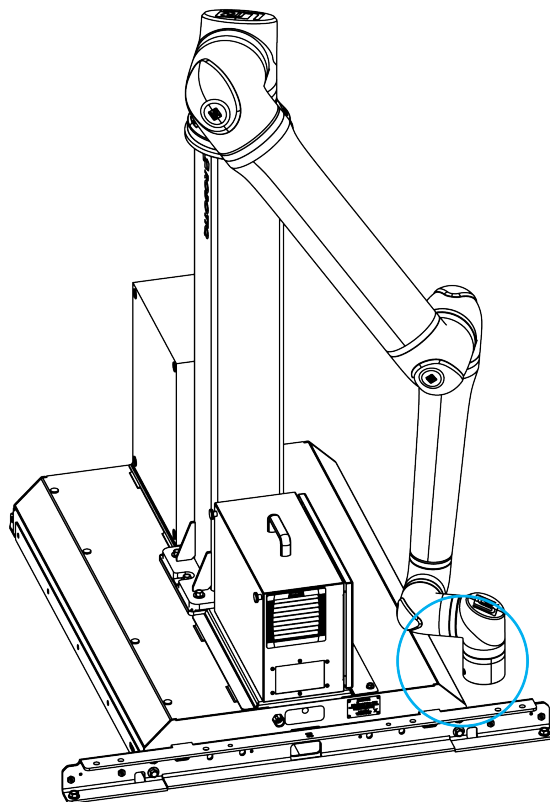

6. Jog the robot so that the robot tool flange is parallel to the ground: change the feature reference to Base, select **Rotation Vector** from the **Units** dropdown menu, and set the tool orientation to the following values: $RX=0^\circ$, $RY=180^\circ$, $RZ=0^\circ$.
7. In the Installation tab, set the TCP value to $[0, 0, 0]$.
8. In the Move tab, in the base reference frame, move the robot using the following values: $X=447$ mm, $Y=-525$ mm, $Z=-1325$ mm.



CAUTION

Move the robot slowly and monitor the movements to avoid collisions.

9. Rotate the column clockwise so that the side of the robot wrist touches the painted surface on the side of the base, as depicted in the figure below.



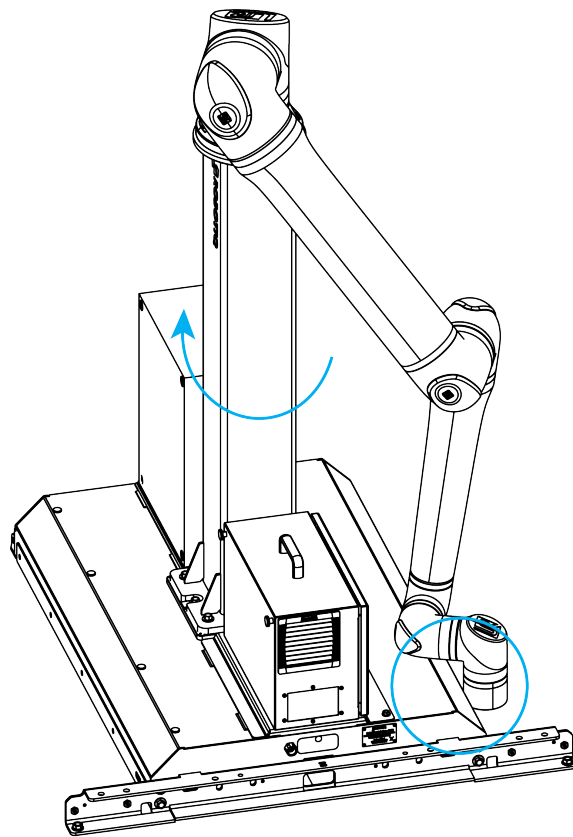

The robot wrist should be touching the painted surface approximately 25 mm (1 in) above the aluminum flat bar on the side of the Solution.

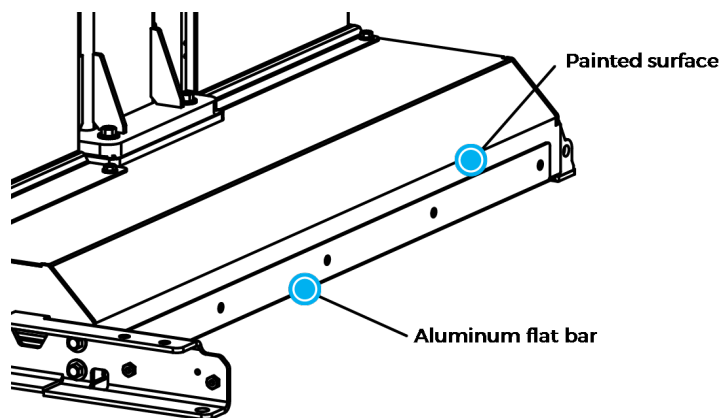

10. On the teach pendant, confirm that the X value of the current position is 447 mm (+/- 1 mm) and the wrist is still in contact with the painted surface on the side of the base.
11. When the X position is within the specified range, remove the M12 x 30 screws, **one at a time**, apply threadlocker on the threaded part of the screws, and retighten to 84 Nm.



CAUTION

If the X position is outside the specified range, repeat steps 3 to 11.

12. Put the robot back in position of use.



Vacuum Gripper Installation



Generic Gripper Installation

To streamline the installation of grippers and accessories, power on the robot and rotate the joints as described in the table below, then power off the robot.

Joint	Position
Base	-90°
Shoulder	-190°
Elbow	-15°
Wrist 1	-65°
Wrist 2	-90°
Wrist 3	90°

If the scope of delivery of the PE20 Palletizing Solution does not include the PowerPick20 Vacuum Gripper, use the following parts to mount another generic gripper on the Palletizing Solution.

- 1x 1/2 BSPP female threaded bulkhead fitting on the side of the pedestal, connected to another 1/2 BSPP female threaded bulkhead fitting at the base (conveyor side)

	 CAUTION
The maximum pressure allowed is 10 bar (145 psi).	

- 4 x cable clips (0.5 m and 1 m) for cable management
- 2 x M8 x 20 hex head cap screws (for the installation of a control box and accessories on the pedestal)

PowerPick20 Gripper Installation (optional)

Upon receipt, the PowerPick20 Gripper is pre-assembled with the following components:

- 1x PowerPick20 Gripper, default configuration
 - 1x Manifold assembly
 - 1 x Small suction cup bracket assembly
 - 4x 110 mm suction cups
- 4x 8 mm air tubes (275 mm length)
- 1x Large suction cup bracket assembly



For more information on how to install the PowerPick20 Vacuum Gripper, please refer to the **Mechanical Installation** section of the PowerPick20 user manual available at robotiq.com/support.

PowerPick20 Vacuum Generation Unit (optional)

1. Loosen the two (2) M8 x 20 hex head cap screws intended to hold the vacuum generation unit until their head is at a distance of approximately 4 mm (3/16 in) from the surface.

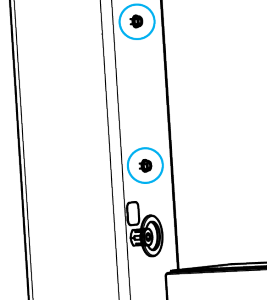

2. Slide the vacuum generation unit onto the two (2) M8 x 20 hex head cap screws.
3. Tighten the screws using the provided 13 mm socket.

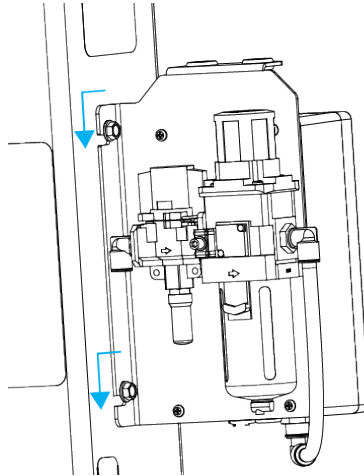

CAUTION

Make sure that there is no pneumatic power present on the bulkhead fitting located at the base (conveyor side).

4. Remove the pneumatic plug from the bulkhead fitting located on the pedestal using the provided 10 mm hex key.

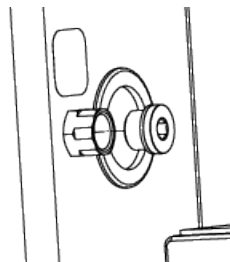

- On the bulkhead fitting, install the 1/2 BSPP to 12 mm tube pneumatic elbow fitting provided using the 21 mm / 24 mm double-ended wrench. Tighten to 26 Nm (19 lb-ft).

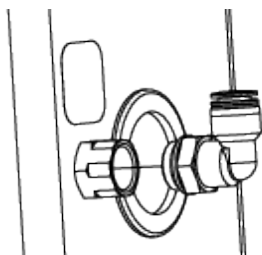

- Insert the end of the 12 mm air tube (providing pneumatic pressure to the Vacuum Generation Unit) into the elbow fitting.
- Push the air tube until it stops.
- Using a 13 mm wrench, remove the two (2) M8 x 20 hex head cap screws from the UR control box support plate.
- Tilt back the UR control box support plate and open the UR control box.
- Remove the grommet on the pedestal.
- Run the open end of the M12-12 pin I/O cable through the opening and down into the cable duct.
- Route the M12-12 pin I/O cable inside the UR control box.
- Plug the hole on the pedestal using the pre-perforated grommet attached to the I/O cable.
- Tuck any excess cable inside the pedestal.
- To complete the electrical connection of the PowerPick20 Vacuum Gripper, please refer to the **Electrical Installation** section of the PowerPick20 user manual available at robotiq.com/support.

TCP and Center of Mass

- In the PolyScope interface, go to **Installation > General**.
- Expand the **TCP** dropdown menu, then select **Payload**.
- Enter the appropriate center of mass and TCP of the gripper.



NOTICE

The TCP and center of mass of the PowerPick20 Vacuum Gripper can be found at section **Tool Center Point and Center of Mass** of the PowerPick20 user manual available at robotiq.com/support.

Cable Management System

Cable Management with Generic Gripper

If the PowerPick20 Vacuum Gripper is not part of the scope of delivery along with the PE20, the following components are provided for the cable management of a generic gripper.

- 3x cable clips + 0.5 m hook and loop (VELCRO®) fastener
- 1x cable clip + 1 m hook and loop (VELCRO®) fastener



Cable management with PowerPick20 Vacuum Gripper (optional)

When mounting a Robotiq PowerPick20 Vacuum Gripper on the PE20 Palletizing Solution, the following components are provided for the cable management system.

- 3 x cable clips + 0.5 m hook and loop (VELCRO®) fastener
- 1 x cable clip + 1 m hook and loop (VELCRO®) fastener
- 1 x tubing curler
- 1 x 12 mm double air tube (3.63 m length)
- 10 x 190 mm cable ties

1. Gripper Mounting

- Mount the gripper on the tool flange. Please refer to **Installation** section for more information.

2. Robot Positioning

- Change the robot's position to install the cable routing system appropriately. Refer to the table below.

Joint	Position
Base	-90°
Shoulder	-190°
Elbow	-15°
Wrist 1	-65°
Wrist 2	90°
Wrist 3	90°

3. Cable Clip Installation

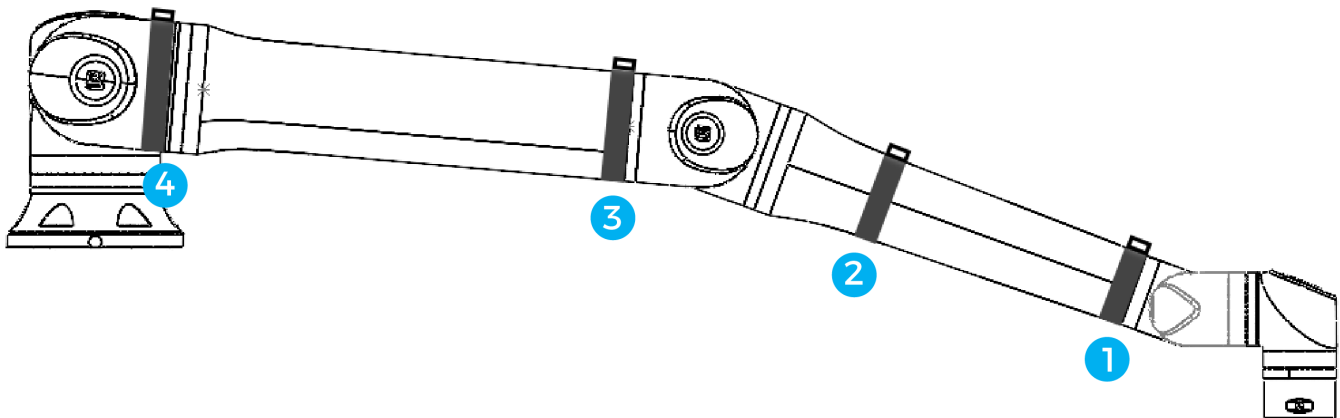

- a. Install the three (3) cable clips with a **0.5 m** hook and loop fastener at positions #1, #2 and #3 as shown in the figure above.
- b. Install the cable clip with a **1 m** hook and loop fastener at position #4 (dark gray section of the shoulder joint) as shown in the figure above.
- c. If applicable, rotate all cable clips so that the plastic mount is facing up; this will ensure the good positioning of the tubing.

4. Tubing Installation

- a. Connect the end of the 12 mm double air tube labeled BASE SIDE to the fittings labeled P1- and P2-.
- b. Push the air tube until it stops.
- c. Find the metallic mark on the tubing that is closest to the vacuum generation unit (there are four (4) metallic marks in total on the tubing).
- d. At the metallic mark, tightly attach the tubing to the cable clip using a cable tie (red component in the figure below).



NOTICE

The cable tie should go through 2 hoops, and the tubing should be laying flat approximately at the center of the plastic mount.

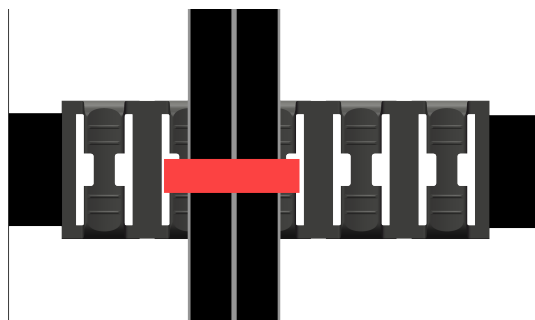

- g. Attach the tubing to a cable clip at every metallic mark, up to the wrist.
- h. Connect the end of the 12 mm double air tube labeled TOOL SIDE to the pneumatic elbow fittings of the PowerPick20 Vacuum Gripper's manifold at the end of the robot arm.
- i. Push the air tube until it stops.



5. Tubing Curler Installation

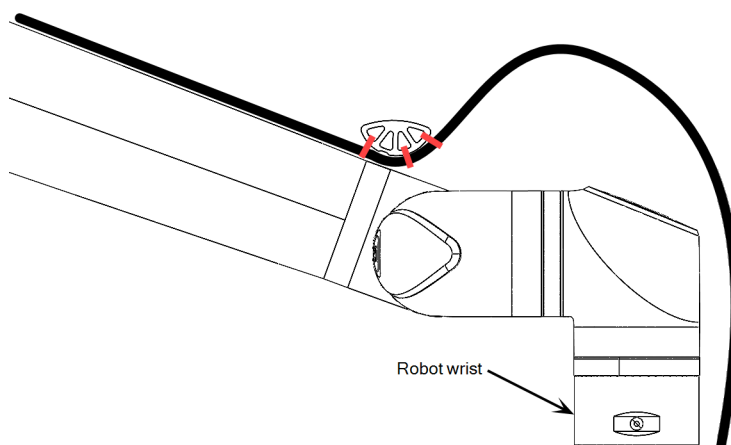

- Place the tubing curler on top of the tubing, as depicted in the figure above.
- Align the tubing curler's notch with the cable tie attached to the cable clip (#1) (the longer section of the tube curler should point towards the wrist of the robot).
- Use the three provided cable ties (red component in the figure above) to secure the tubing to the tubing curler, and make the tubing follow the arch of the tubing curler.

6. Finalization

- Verify that the tubing travels along each straight section of the robot. Move cable clips #2 or #3 to adjust the position of the tubing if needed.
- Rotate the tubes to remove twists in the tubing, if any.
- Verify each hook and loop fastener and tighten them until the cable clips cannot move when being pulled or pushed.
- Verify each cable clip and tighten the cable tie to prevent the tubing from sliding.
- Cut the excess length from the cable ties.

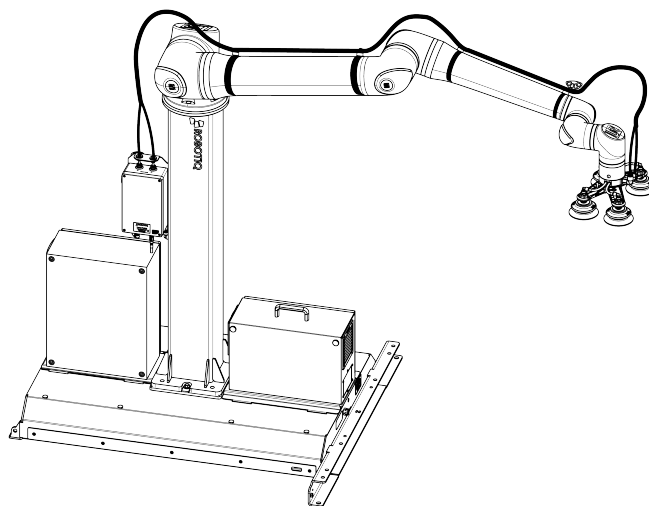

Fig. 3-3: Depiction of Complete Cable Management

Box Sensor (Single Box Type)

1. Run the box sensor cable through a hole under the robot control box.
2. Connect the wires to the terminal blocks of the robot control box:
 - Connect the brown wire to a 24 V terminal in a Digital Inputs block
 - Connect the blue wire to a 0 V terminal in a Configurable Outputs block
 - Connect the black wire to a digital input (DI) terminal (e.g. DI4, as shown in the figure below)
3. Secure each connection using a 2 mm flat head screwdriver (not provided).



NOTICE

Follow good cable management practices.

Use the plate under the control box, and use a grommet if needed (not included).

4. Install each box sensor on a bracket using the provided screws.
5. Position each box sensor bracket so it can detect the box to be picked.
6. Connect each box sensor's M8 connector cable to the corresponding sensor.

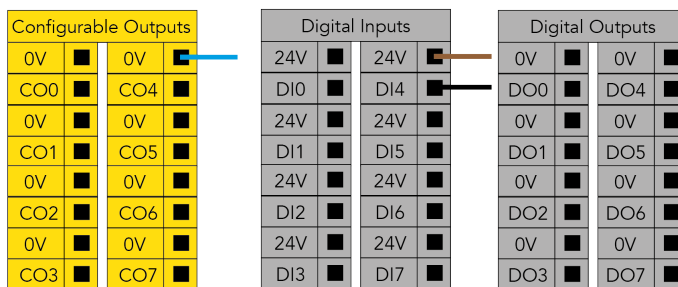
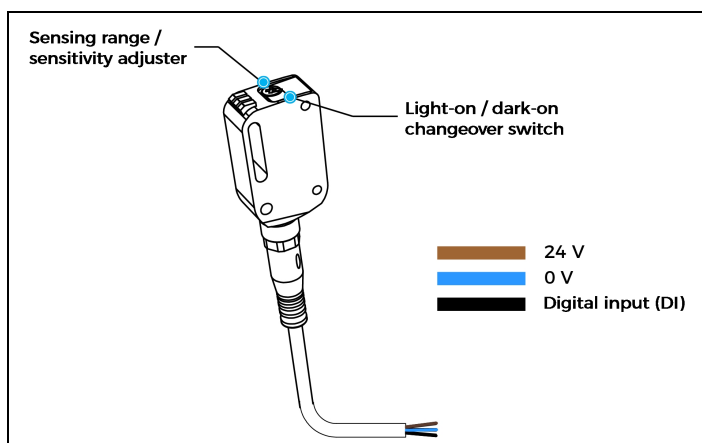

7. Once the system is running, adjust the detection distance of each box sensor using the sensitivity adjuster.



NOTICE

In order for the sensor to provide a high state when detecting a box, set the sensor to the light-on switching mode (green light beside "L"). To do so, press the light-on / dark-on changeover switch and hold for one to four seconds.



Box Sensor (Multiple Box Types - Multi-Pick Feature)



NOTICE

The example below presents a configuration with two box types and two box sensors. Should the user need to pick more than two boxes, add a sensor for each additional box type to be picked.

The scope of delivery includes one (1) box sensor. Additional sensors can be ordered; refer to the **Spare Parts, Kits and Accessories** section for more information.

1. Connect each box sensor as described in the **Box Sensor (Single Box Type)** section.
2. Take note of the digital input terminal to which each box sensor is connected.



NOTICE

The figure below shows an example in which the digital input terminal for box sensor #1 is DI0, and the digital input terminal for box sensor #2 is DI1.

3. Lay a wire between an unused digital input terminal and an unused digital output terminal (this is depicted by the green wire in the figure below).



NOTICE

In the figure below, digital output DO0 will activate digital input DI4.

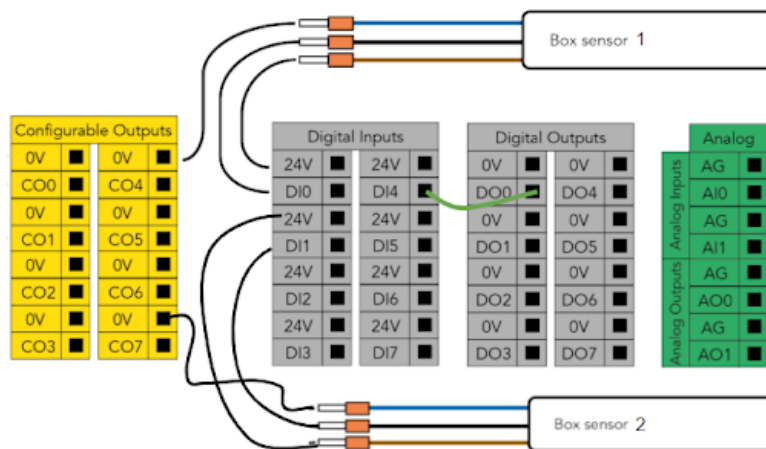

Fig. 3-4: Wiring Box Sensors for Multiple Box Types



CAUTION

Connection Between Digital Input and Digital Output

This wiring procedure is the hardware step of the multi-pick feature, and will not make the feature functional on its own unless it is properly programmed in the robot software. Please refer to the **Palletizer Node With Multi-Pick Feature** section to go through the software steps and enable the multi-pick feature.



The end result of this wiring procedure is for the robot to receive a combined signal indicating that both box sensors have been activated simultaneously, and that it can pick up the group of boxes altogether.

And so, when both box sensors detect a box, the digital output (DO0 in the above figure) will send that combined signal to the robot.

For that reason, the digital output must be connected to digital input (DI4 in the above figure) for it to be usable in the robot program.





Moving and Positioning the Solution

	 WARNING
	<p>Failure to properly secure and install the equipment can result in material damage and bodily injury.</p> <p>The warranty will not cover material damage resulting from an installation that does not comply with the instructions found in this manual.</p> <p>The transport, lifting, and moving of the Palletizing Solution should be done by qualified and authorized personnel. Failure to do so may result in material damage, bodily injury or death.</p>

The Palletizing Solution can be moved and repositioned using a pallet truck or forklift truck.

There are two fork entry openings on the aisle side of the palletizer base for use with a lifting device.

The Solution can be moved around while partially or completely assembled.

	 WARNING
	<p>Tip Over Hazard</p> <ul style="list-style-type: none"> • The forks of the pallet truck or forklift truck must be at least 1,065 mm (42 in) in length. • The weight capacity of the pallet truck or forklift truck must be at least 250 kg (550 lb). • The Solution must be transported on a level, even and solid concrete surface using a pallet truck or forklift truck. • The robot should be positioned as per the moving and positioning instructions. • The cabling and tubing must be disconnected before transportation. • The Solution should be lifted as little as possible, and attention must be paid to the center of gravity to reduce the risk of tip over. • It is the responsibility of the user to determine a safe and stable course of action for the moving of the Solution using rigging and hoisting equipment. • Employees should be qualified and properly trained on how to use the lifting/hoisting/rigging equipment as well as the Solution • The Solution should be secured and stable prior to its moving and lifting <p>Failure to account for these factors may result in material damage, bodily injury or death.</p>

Although the Solution can be assembled where needed, it may need to be moved to its final location afterwards.



Please follow the steps below to safely move the Solution.

1. Set the robot in a transport position by referring to the joint positions below. Disregard this step if the robot has not been installed yet.

Joint	Position
Base	-63°
Shoulder	-200°
Elbow	-125°
Wrist 1	90°
Wrist 2	90°
Wrist 3	90°

2. Disconnect the power and pneumatic supplies as well as any other cabling that may interfere with the movement of the Solution.
3. Place the teach pendant on its rack at the operator station, or place it on the support rack of the robot's control box and run the teach pendant cable on the base of the Solution.

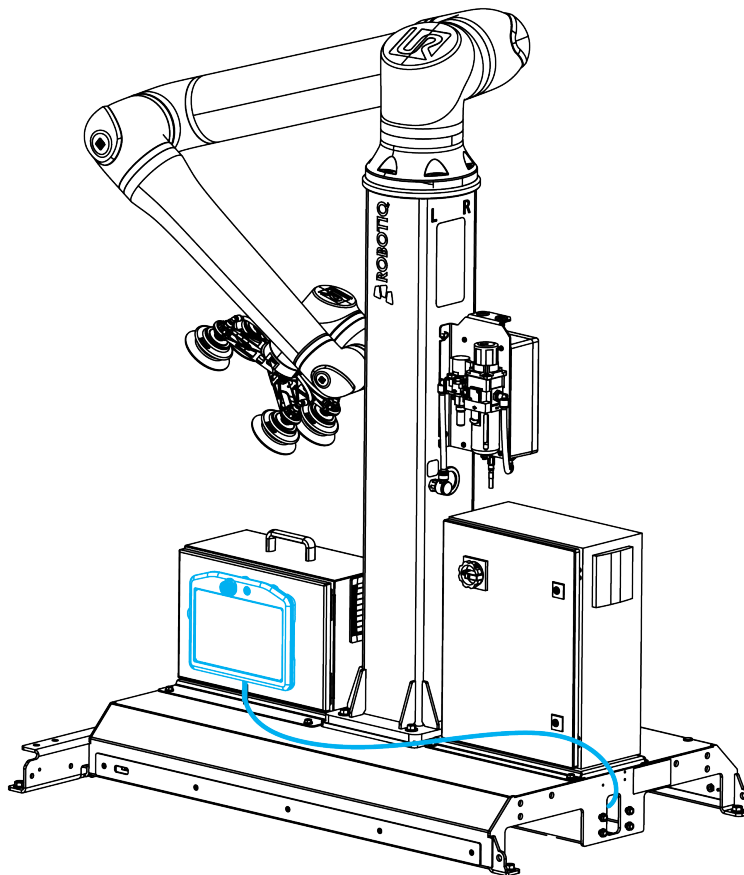

4. Insert the forks of the pallet truck or forklift truck in the fork entry openings until they stop. Make sure that the teach pendant cable and any other cable located at the front of the solution are not pinched during this operation.



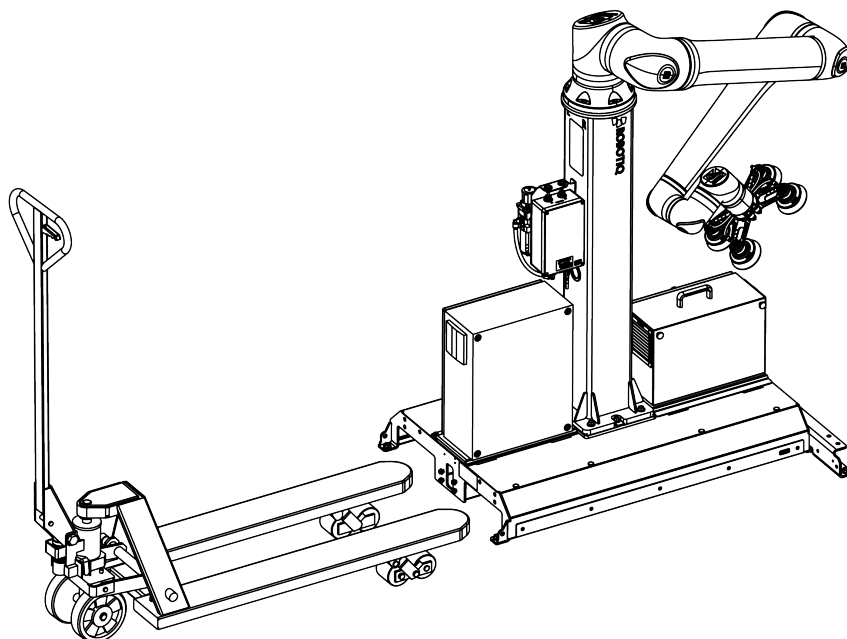



5. Slightly raise the forks so that the Solution remains close to the ground for transport.
6. Slowly and carefully move the Solution to its final location.



Anchoring the Solution

The Robotiq Palletizing Solution must be anchored for it to be used.



Contact Robotiq if anchoring is not possible.

	 WARNING
	<p>Tip Over Hazard</p> <ul style="list-style-type: none"> • The solution must be anchored at all corners. • The anchors provided with the Solution are Wej-It Ankr-TITE® Wedge Anchors model ATG1233 (1/2 x 3-3/4), but they may not be in compliance with the local rules, regulations and standards in force where the Solution is installed (the technical data sheet can be found on the Robotiq support website, in the Palletizing Solution section). A qualified engineer should measure the anchoring resistance of the anchors and confirm they can resist the following loads, or select alternative anchors designed to resist the following loads. <ul style="list-style-type: none"> ◦ Operational load (per anchor): 1,200 N tensile resistance and 80 N shear resistance ◦ Load at emergency stop (per anchor): 2,640 N tensile resistance and 279 N shear resistance ◦ Design load (per anchor): 6,200 N tensile resistance and 2,350 N shear resistance • If the anchors provided with the Solution comply with the local rules, regulations and standards in force where the Solution is installed, use them in compliance with the following installation requirements. <ul style="list-style-type: none"> ◦ Anchors must be installed in concrete with a minimum strength of 17 MPa (2,500 psi). ◦ Anchors must penetrate at least 65 mm (2-1/2 in) into the concrete. ◦ Anchors must be located at least 200 mm (8 in) from any edge of a concrete slab. ◦ Anchors must be installed at least 150 mm (6 in) from one another. ◦ Anchors must be installed in conjunction with the provided serrated flange locknuts. ◦ Anchor nuts must be tightened to a torque ranging between 68 Nm and 74 Nm (50-54 lb-ft). <p>Failure to account for these factors may result in material damage, bodily injury or death.</p>

	 WARNING
	<p>Appropriate personal protective equipment as required by safe work practices must be worn when anchoring the Solution, namely safety glasses, masks, steel-toe boots.</p>

Follow the steps below when using the anchors provided with the Solution.

1. Position the base at its final location.

	 CAUTION
	<p>Make sure the Solution cannot move during the following steps.</p>

2. Use a rotary hammer and a 1/2 in concrete drill bit to drill a hole with a depth of at least 80 mm (3 in) at each of the four (4) anchoring points at the base.



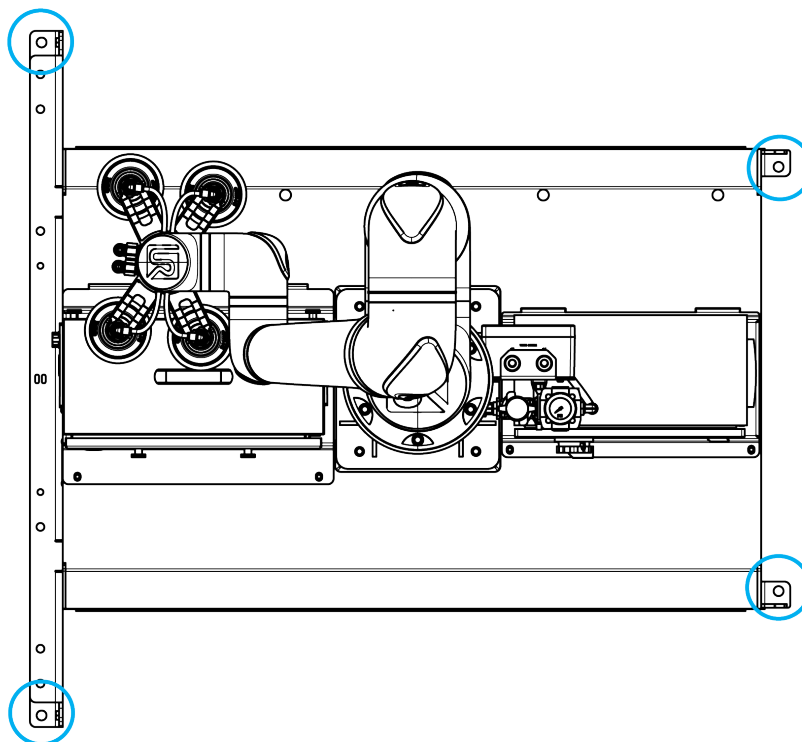

3. Clear the dust around and in the drilled holes.
4. Insert the wedge anchors in the holes and make sure that they penetrate at least 65 mm (2-1/2 in) into the concrete.



CAUTION

The base of the Solution must be placed as parallel as possible relative to the ground, in all directions, in particular the two zones where the pallets will be located.

It is unadvised to level the base of the Solution to account for uneven areas in the floor since this may result in palletizing issues.



CAUTION

The maximum gap between the anchoring points and the ground should be 2 mm (0.08 in).

Should the gap between the anchoring points and the ground be greater than 2 mm (0.08 in), use the 1.9 mm (0.075 in) shim washers to compensate. Use the shim washers as an indicator to verify the height of the gap. Use a pallet truck or forklift truck to lift the base and install the shim washers.

5. Add the four (4) 1/2 in-13 serrated flange nuts.
6. Tighten to a torque ranging between 68 Nm and 74 Nm (50-54 lb-ft) using a 3/4 in (19 mm) socket.





Finalization and Power On

If pneumatic power is needed, or if a PowerPick Vacuum Gripper is used, compressed air should be supplied at the inlet port on the conveyor side of the base. The port thread size is BSPP 1/2 (G 1/2).

Should the Solution need to be moved occasionally, a quick connect adapter can be installed. A BSPP 1/2 (G 1/2) to NPT 1/2 adapter is provided with the kit.

1. Connect the power cable to the power outlet.
2. Pressurize the system using the shut-off valve if needed.
3. Turn on the main power switch located on the Robotiq control box.
4. Power on the robot.

	 WARNING
	Make sure to perform a risk assessment before using the Solution. For more details, refer to the Safety section.

3.4.4. Atypical and Custom-Sized Pallets



By default, the PE20 Palletizing Solution is designed to be used with a wide range of standard-sized pallets.

If it is used in conjunction with atypical- or custom-sized pallets, it may be necessary to adjust the pallet sensors so that they trigger properly and accurately. If the application requires such a configuration, please [contact the Robotiq support team](#).

Certain pallet types may prove difficult to detect relative to the base of the Solution (i.e., if the top of pallet does not rest against the base of the Solution, which is often the case with stackable plastic pallets). In such cases, Robotiq recommends installing offset spacers and to make them rest against the pallet blocks, legs or feet. Please refer to the **Overhang Spacers** section for more information.

3.4.5. Conveyor

The Robotiq Palletizing Solution does not come equipped with a conveyor. However, the palletizing cell, as construed in this instruction manual, includes a conveyor. It is thus important to enforce standard EN 619 (or the equivalent in your region).

	 CAUTION
	The appropriate safety clearance between the conveyor and the pallet must comply with the distances set forth in the layout.

3.4.6. Physical Clearance and Reachable Area of the Robot

The computed trajectories allow the boxes or the robot to overrun the edges of the pallet when the robot moves the boxes to their final position. Mitigation measures can be put in place to prevent a transient or quasi-static impact between a box, or the robot itself, and an operator. Below are some examples:

- Physical assets such as guardrails and bollards, which prevent the operator from accessing the area.
- Sensors such as light curtains or area scanners which can detect the presence of a person, and stop the system before that person reaches the danger zone.



- The **Add virtual planes around pallet(s)** option available in the Settings tab of the Palletizer node of the Robotiq URCap to contain the overrun within a certain distance of the pallet. Please refer to the **Palletizer Node** section to learn more about this option.

For PE20, the boxes won't overrun over the pallet edges if the height of the pallet is greater than 12cm (4.75in). However, for smaller pallets, potential overrun can be determined by the following formulae:

Front overrun

The potential front overrun is the highest value obtained using the following formula:

Potential front overrun (mm) = $\max(0.1 \times \text{box height}, 1280 - \text{pallet depth}, 180 + \text{extra bracket reach} + (0.1 \times \text{box height}) - (\text{minimum horizontal box dimension} / 2))$

Side overrun

Potential side overrun (mm) = $(\text{box diagonal} / 2) + \text{robot reach} + \text{extra bracket reach} - \text{pallet width} - 295$

Trajectories are not limited to hovering over the picking position, the base of the Solution, and the pallets. It is thus important to implement physical safeguarding devices next to the picking area, depending on the layout of the palletizing cell. The robot's reachable area should be clearly identified and marked on the ground.



NOTICE

When the robot is palletizing on one side, and no pallet is present on the opposite side, the Palletizing Solution computes trajectories based on the assumption that there are no obstacles on the opposite side. The robot's elbow (joint #2) can therefore extend to the side where no pallet is present. For a UR20, the potential overrun is represented by a cylinder with a radius of 1000 mm, with its axis aligned with the Z-axis of the robot base.

Floor marking

Floor marking to delineate the working zone should be added.



3.5. Other Grippers

It is possible to use a gripper other than the PowerPick20 Vacuum Gripper. If another gripper is used, it is important to validate that its shape is within the gripper model used for the collision detection algorithm of the software. If the shape of the alternative gripper does not correspond with the shape of the following models, it might function as well, **but Robotiq does not guarantee that there will be no collision.**

The dimensions of the gripper model depends on the dimensions of the box to palletize and are obtained using the following criteria:

Box Footprint ($A_{\text{box}} \times B_{\text{box}}$)	Gripper Footprint ($A_g \times B_g$)	Gripper Height (C_g)
$A_{\text{box}} < 105 \text{ mm}$ OR $B_{\text{box}} < 55 \text{ mm}$	$A_g = A_{\text{box}} - 1 \text{ mm}$ $B_g = B_{\text{box}} - 1 \text{ mm}$	110 mm
$A_{\text{box}} > 450 \text{ mm}$ OR $B_{\text{box}} > 350 \text{ mm}$	$A_g = A_{\text{box}} - 40 \text{ mm}$ $B_g = B_{\text{box}} - 40 \text{ mm}$	55 mm
Otherwise	$A_g = 200 \text{ mm}$ $B_g = 130 \text{ mm}$	110 mm

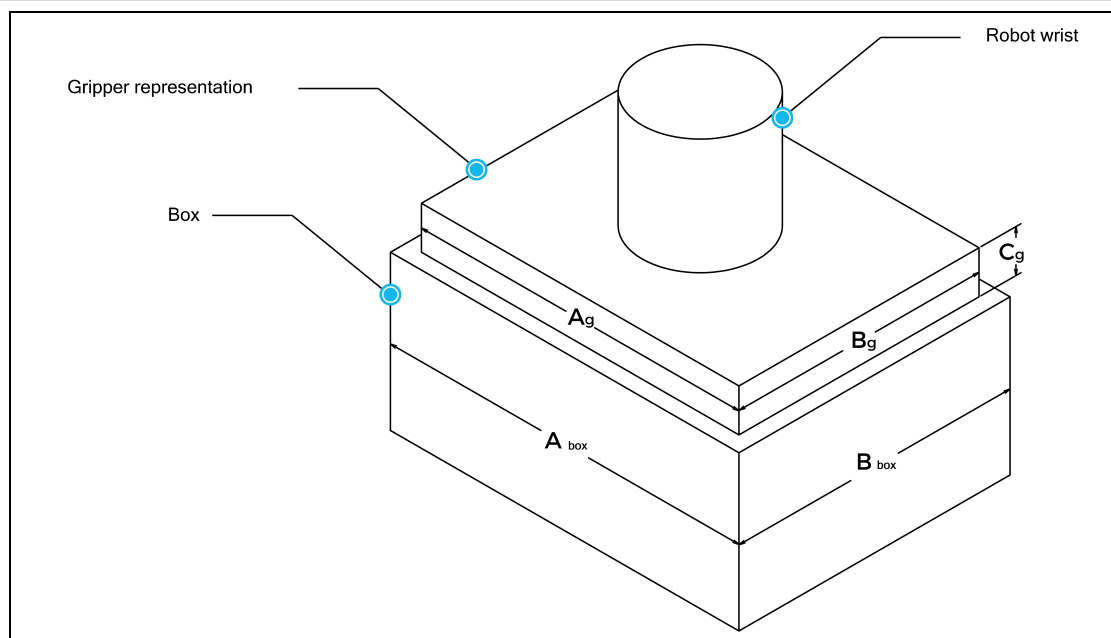

If a TCP offset is added in the X or Y directions, the software will act as if an extra reach bracket is being used.

Bracket representation

Height	Width	Length	Direction
31.5 mm	75 mm	Same length as TCP offset (X, Y)	Same direction as TCP offset (X, Y)

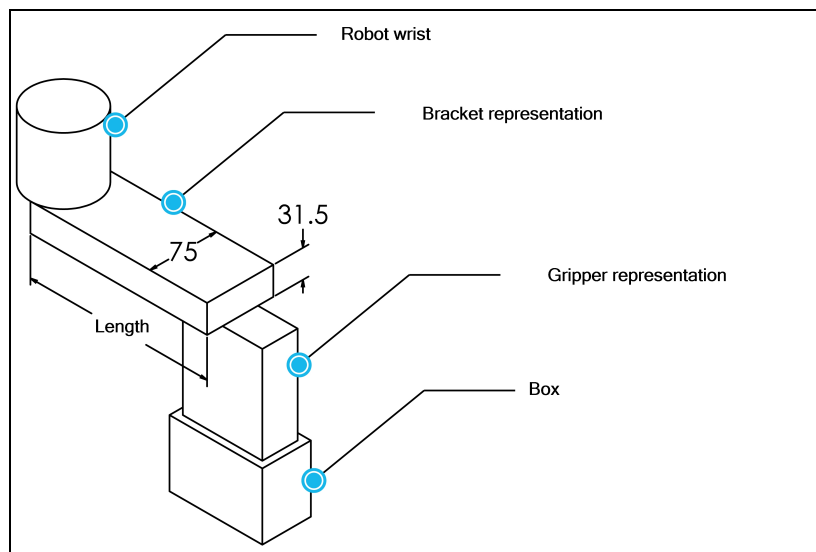

3.6. URCap Package



WARNING

Starting in July 2023, all new Palletizing Solutions sold are not compatible and not supported on Universal Robots CB Series. Only e-Series and new generations of Universal Robots can be used.

For more information, please contact the Robotiq support department.

The Robotiq URCap package provides a graphical user interface and enables direct serial communication to the robot control box.

3.6.1. URCap Package Installation

Make sure the Robotiq Palletizing Solution is installed properly.

Refer to the **Mounting and Installation** section for detailed information.

Before proceeding with the installation of the URCap package, make sure the Universal Robots control box is compatible with the URCap package.

To download the latest version of the Copilot URCap required to run the Palletizing Solution, refer to the Robotiq support website at robotiq.com/support under the sections Palletizing Solution, Universal Robots and Software.

- Download the Copilot URCap and extract it on the root of a blank USB storage device.
- Insert the USB storage device in the UR teach pendant or robot control box.
- On the teach pendant, tap the **triple bar icon** in the upper right corner of the screen.
- Tap **Settings**.
- Tap the **System** button in the navigation pane on the left.
- Tap the **URCaps** button.
- Tap the **plus (+)** button to look for the **.urcap file** in the available drives.
- Select the Copilot URCap (UCS-X.X.X.) to install the URCap.
- Once the file is selected, tap the **Open** button.
- Tap the **Restart** button to complete the URCap installation. By doing so, you accept the **license agreement** detailed in the URCap information textbox.



3.7. Robot Configurations



NOTICE

To ensure the appropriate use of the Palletizing Solution, certain configurations found in the Safety section must be performed.

3.7.1. Robot Limits

To ensure the effective operation of the Solution, Robot Limits should stay at the Least Restrictive setting. Tool speed (1) and tool force (2) can be adjusted as required. Please note that adjusting these settings will reduce the Solution's cycle time.

! DANGER
Use of Safety Configuration parameters different from those defined by the risk assessment can result in hazards that are not reasonably eliminated or risks that are not sufficiently reduced.

Factory Presets

Most Restricted Least Restricted

Custom

Limit	Normal	Reduced
Power	1000 W	300 W
Momentum	100.0 kg m/s	25.0 kg m/s
Stopping Time	1000 ms	400 ms
Stopping Distance	2000 mm	500 mm
1 Tool Speed	1000 mm/s	1000 mm/s
2 Tool Force	140.0 N	150.0 N
Elbow Speed	5000 mm/s	1500 mm/s
Elbow Force	250.0 N	150.0 N

Safety password:

3.7.2. Joint Limits

Joint limits must be configured.

1. Tap **Installation** → **Safety** → **Joint Limits**
2. Unlock the section with the password and change the values.
 - The minimum and maximum values for the Elbow are -167° and 3° .
 - The minimum and maximum values for the Wrist #3 are -273° and 273° .

PROGRAM <unnamed> INSTALLATION default

98E0 C76F

General

Safety

Robot Limits

Joint Limits

Joints	Range	Normal Mode		Reduced Mode		
		Minimum	Maximum	Minimum	Maximum	
Base	-363 – 363 °	-363	363	-363	363	+2 ° / -2 °
Shoulder	-363 – 363 °	-363	363	-363	363	+2 ° / -2 °
Elbow	-363 – 363 °	-167	3	-167	3	+2 ° / -2 °
Wrist 1	-363 – 363 °	-363	363	-363	363	+2 ° / -2 °
Wrist 2	-363 – 363 °	-363	363	-363	363	+2 ° / -2 °
Wrist 3	-363 – 363 °	-273	273	-273	273	+2 ° / -2 °

Maximum speed

Joints	Maximum	Normal Mode		
		Normal Mode	Reduced Mode	
Base	max: 131 %/s	131	131	-11 %/s
Shoulder	max: 131 %/s	131	131	-11 %/s
Elbow	max: 161 %/s	161	161	-11 %/s
Wrist 1	max: 221 %/s	191	191	-11 %/s
Wrist 2	max: 221 %/s	191	191	-11 %/s
Wrist 3	max: 221 %/s	191	191	-11 %/s

Safety password:



3.7.3. Configurable Inputs

Two of the buttons found on the push button enclosure can be configured to trigger Pause and Restart commands.

The direct input (DI) terminals to which the Pause and Restart wires need to be connected are at the user's choice.

1. Tap **Installation > General > I/O Setup**.
2. Set the Input Signal digital_in[0] to **Start-Prog** and digital_in[1] to **Pause-Prog**.

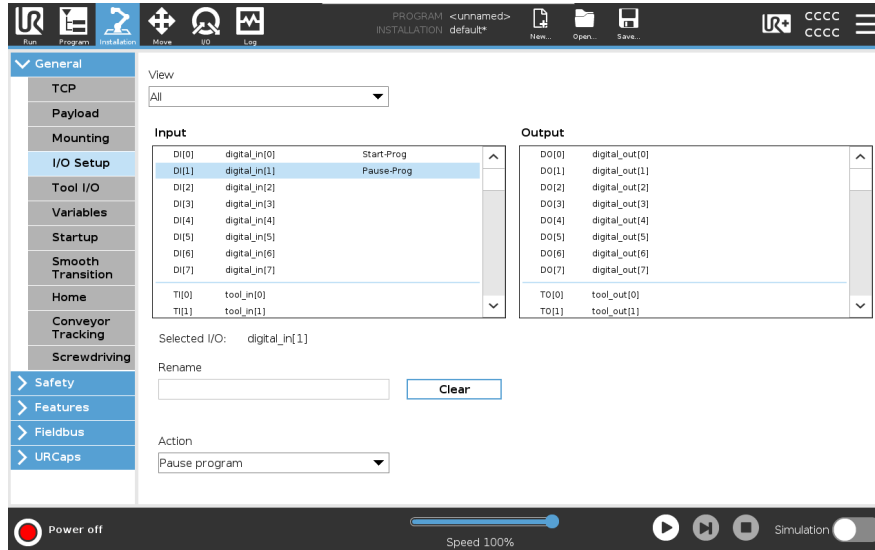

3.7.4. Safety Planes

Safety planes, programmable via UR's PolyScope, can be added to the front and sides of pallet zones as safeguarding measures in case of system failure, mainly to prevent the robot from overrunning the edges of the pallet while carrying boxes. Please refer to the instruction manual of the UR robot used for more details in regard to adding and setting up safety planes.



NOTICE

The trajectories computed in the Palletizer node allow boxes to overrun the edge of the pallet. This should be accounted for when adding and setting up safety planes. Please refer to the **Physical Clearance and Reachable Area of the Robot** section for more information. The values can vary depending on your configuration.

4. Operation



CAUTION

All information in this section must be read and understood before using the Solution.

4.1. Start Up

Perform the following steps after the mechanical and electrical installation.

1. Make sure the URCap package is installed. Please refer to the **URCap Package Installation** section for more information.
2. Configure the TCP. Use the appropriate values based on the gripper configuration. Please refer to the **Specifications** section for more details.
3. Test the box sensor and the digital inputs : Place an object in front of the box sensor to validate if the signal changes in the I/O interface of PolyScope.
4. Test the Vacuum Gripper: Make sure the compressed air is supplied. Go to the I/O interface in PolyScope and manually activate the digital output (DO) that corresponds to the vacuum of the gripper. Repeat for the DO corresponding to the blow off action of the gripper.

4.2. Palletizing Operation Instructions



WARNING



There is no emergency stop button directly on the Robotiq Palletizer. The emergency stop button used by the Palletizing Solution is the one found on the robot's teach pendant. Make sure operators know how to stop the Solution in case of emergency.

The following section explains the logical operation of the Palletizing Solution based on the operator's actions, as well as responses such as signals, pallet and box sensor behaviors, etc. These steps are also represented in the form of diagrams in the **Palletizing Operation Diagrams** section.

1. Once the program is selected:
 - a. Tap the **Play** button on the robot teach pendant.
 - If the **Validate pallet state at program startup** option is checked in the Palletizer node settings, the **Confirm current pallet state** window will appear on the robot teach pendant. Enter the pallet state and tap **OK**. The Palletizer will then start palletizing.
2. The operator has access to a **Pause** button and a **Restart** button, both available on the push button enclosure. If an accident occurs, an emergency stop button is also present on the robot teach pendant.
3. When using the **Confirm new pallet(s) ready** button:
 - a. Once a pallet is full, the status light will turn solid blue or blinking blue (see **Status Light States** section for all the information about light states).
 - b. Remove the full pallet and place an empty one.
 - c. Press the **Confirm pallet(s) ready** button on the push button enclosure to confirm that the pallet is ready and that the area is cleared.



4. When NOT using the **Confirm new pallet(s) ready** button with safeguarded devices:
 - a. Once a pallet is full, the status light will turn solid blue or blinking blue (see **Status Light States** section for all the information about light states).
 - b. Enter the safeguarded area; palletizer falls in safeguard state.
 - c. Remove the full pallet and place an empty one.
 - d. Exit the safeguarded area and, after making sure no one is in the palletizer work area, make a safeguard reset to restart the palletizer.

	 CAUTION
	When adding safety components, make sure to respect all electrical wiring standards (example for redundant signals).

5. To safely resume the solution after a protective stop:
 - a. Ensure the work area is clear and safe.
 - b. Validate the protective stop window and press the resume button to restart the program.
 - c. If necessary, stop the program, reposition the robot and restart the program.
6. To safely resume after an emergency stop:
 - a. Ensure the work area is clear and safe.
 - b. Release the emergency stop button and validate the emergency stop window.
 - c. Restart the robot.
 - d. If necessary, reposition the robot and restart the program.

4.3. Palletizing Operation Diagrams

The following diagrams explain the logic of the Palletizing Solution process based on the operator's actions, as well as responses such as signals, pallet and box sensor behaviors, etc. These steps are also explained in the **Palletizing Operation Instructions** section.

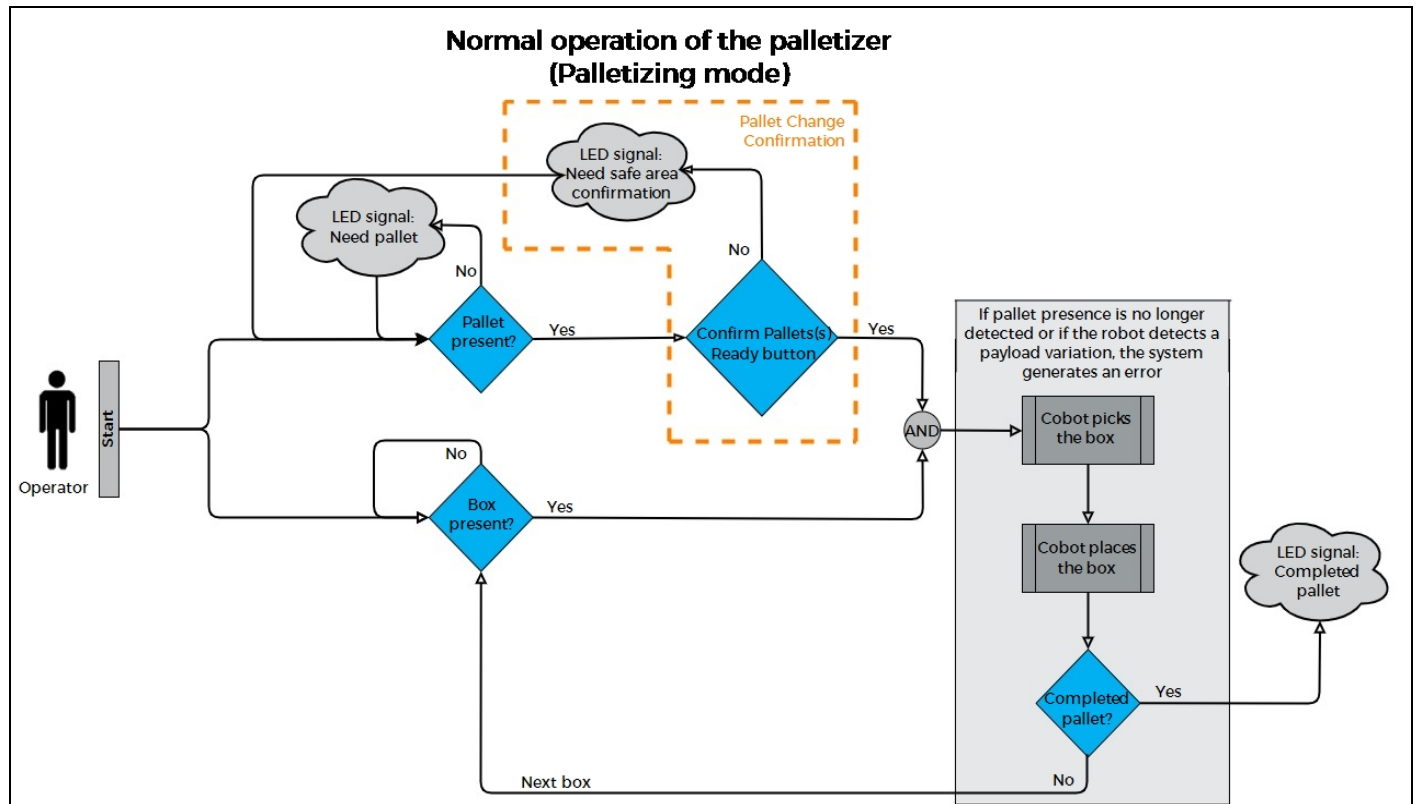

Please refer to the **Status Light States** section for further information about light states.

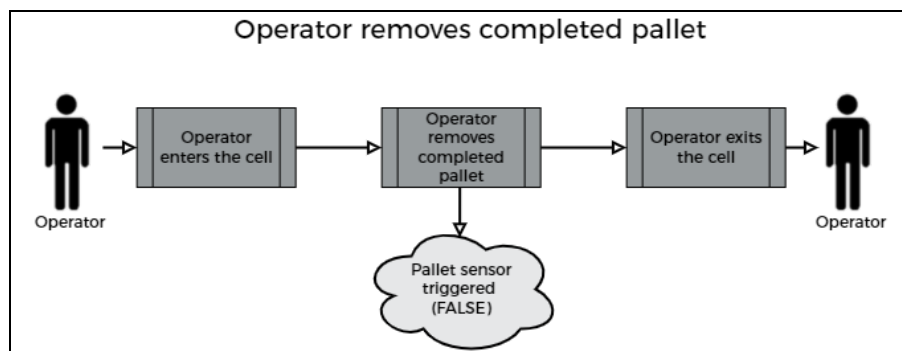
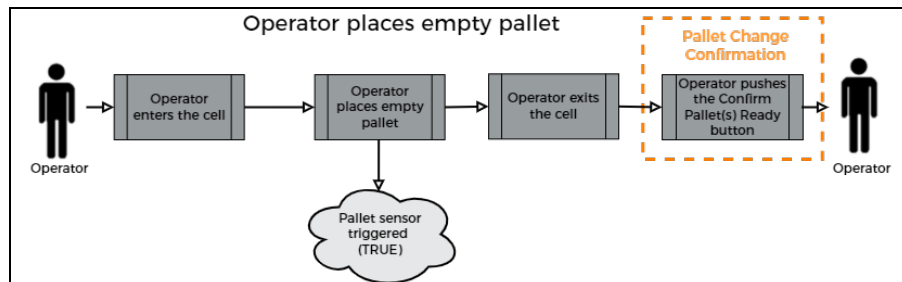

4.4. Status Light States



Status Light Activity



- **Fast blink:** 2 Hz (0.25 s ON, 0.25 s OFF)
- **Slow blink:** 0.5 Hz (1 s ON, 1 s OFF)

Color and signal type	Condition status	Cause or action needed
RED Fast blink	The Robotiq control box (PLC) is unable to communicate with the robot control box (UR)	<ul style="list-style-type: none"> • The robot has been started and needs time to boot up (Polyscope has not loaded yet) • Make sure your Ethernet/USB adapter is connected: the LED on the Ethernet adapter should be ON. • Make sure the Ethernet cable between the Robotiq control box and robot control box is properly connected to the USB adapter. • Try powering off the system (both the robot and the Robotiq control box). Wait 1 minute. Power up the system again.
RED Solid	A Protective or Emergency stop has occurred.	<ul style="list-style-type: none"> • Follow the procedure required by the system to recover from either a Protective or Emergency stop.
YELLOW Slow blink	A Safeguard Stop has occurred.	Press the safeguard reset button.
BLUE Solid	<ul style="list-style-type: none"> • Pallet is complete or missing; <p style="text-align: center;">AND</p> <ul style="list-style-type: none"> • The system is palletizing on the other side. 	Place a new pallet
BLUE Fast blink	<ul style="list-style-type: none"> • Pallet is complete, system is idle; <p style="text-align: center;">OR</p> <ul style="list-style-type: none"> • Pallet is not detected, system is idle. 	Place a new pallet
WHITE Solid	<ul style="list-style-type: none"> • The Robotiq control box (PLC) is connected to the robot control box. • Program running without Palletizer node. 	N/A
GREEN Solid	A program with a Palletizer node is running but the pallet present is not completed.	N/A



4.5. Solution Mobility (Wash Down and Production Line Shifts)

	 WARNING
	<ul style="list-style-type: none"> • Failure to properly secure and install the equipment can result in material damage and bodily injury. In addition, note that the warranty will not cover material damages resulting from an installation that did not comply with the instructions found in this manual. • The transport, lifting, and moving of the Palletizing Solution should be done by qualified and authorized personnel. <p>Failure to do so may result in machine damage, bodily injury or death.</p>

	 WARNING
	<p>Tip Over Hazard</p> <ul style="list-style-type: none"> • The forks of the pallet truck or forklift truck must be at least 1,065 mm (42 in) in length. • The weight capacity of the pallet truck or forklift truck must be at least 250 kg (550 lb). • The Solution must be transported on a level, even and solid concrete surface using a pallet truck or forklift truck. • It is the responsibility of the user to perform a risk assessment to account for the potential regular repositioning of the Solution. • The robot should be positioned as per the instructions found in the Solution Mobility (Wash Down and Production Line Shifts) section. • The cabling and tubing must be disconnected before transportation. • The Solution should be lifted as little as possible, and attention must be paid to the center of gravity to reduce the risk of tip over. • It is the responsibility of the user to determine a safe and stable course of action for the moving of the Solution using rigging and hoisting equipment. • Employees should be qualified and properly trained on how to use the lifting/hoisting/rigging equipment as well as the Solution. • The Solution should be secured and stable prior to its moving and lifting <p>Failure to do so may result in material damage, bodily injury or death.</p>

	NOTICE
<p>If external cables are connected to the Solution (i.e., external I/Os, safety devices, etc.), it is recommended to add connectors close to the base of the Solution. This will allow for an easier and quicker moving operation, and prevent the user from managing long segments of cable, and potentially damage them along the way.</p>	

The Palletizing Solution can be moved and repositioned using a pallet truck or forklift truck.

There are two fork entry openings on the aisle side of the palletizer base for use with a lifting device.



The Solution can be moved around while partially or completely assembled.

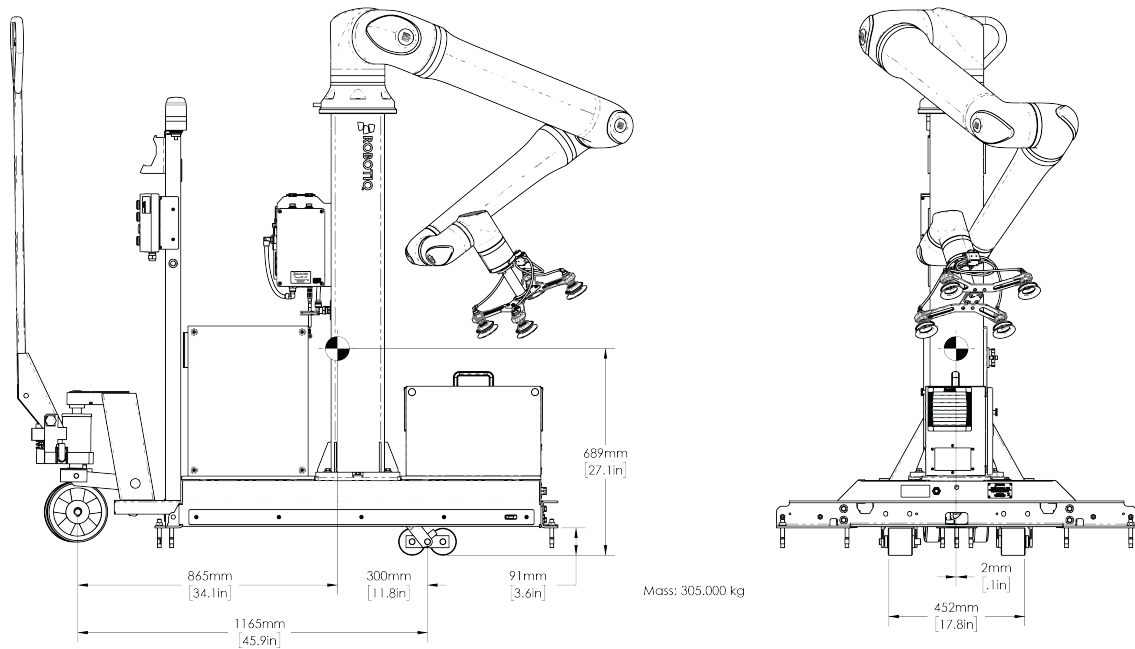

Fig. 4-1: Mass and center of gravity of PE20 Palletizing Solution with robot and pallet truck.

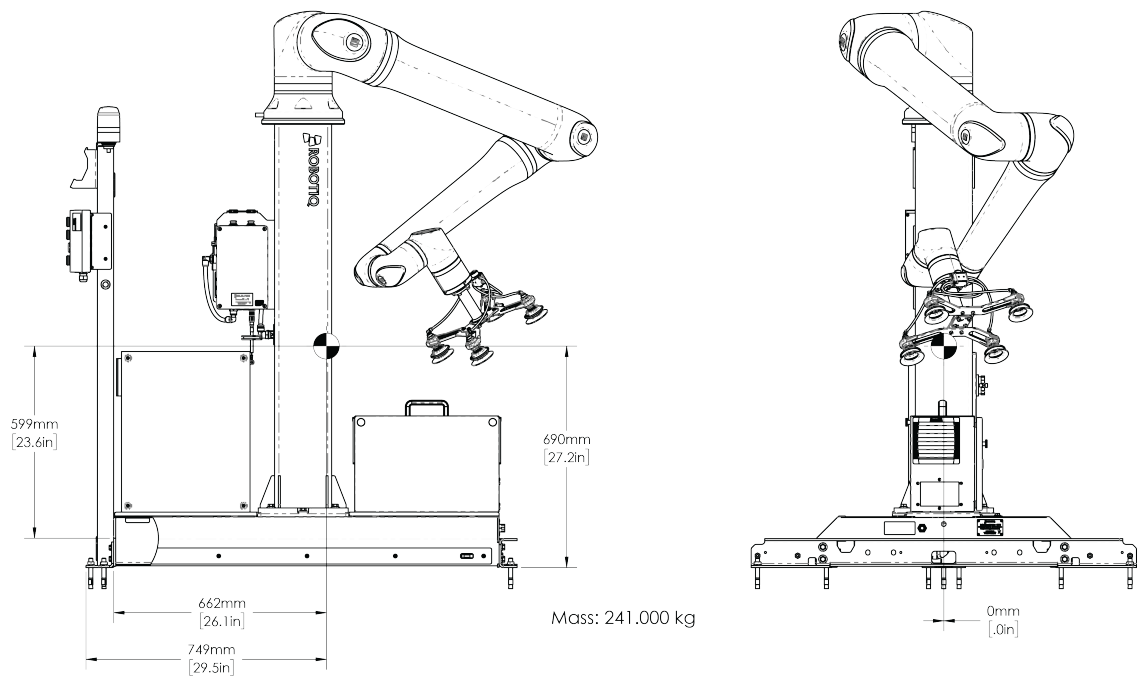
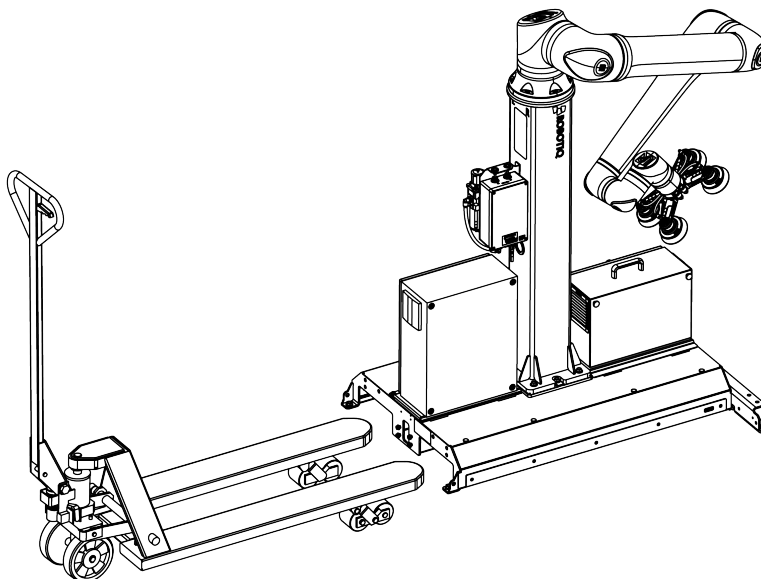

Fig. 4-2: Mass and center of gravity of PE20 Palletizing Solution with robot.





4.5.1. Approximate Repositioning of the Solution

The following method does not guarantee a precise repositioning of the Solution.

Robot movements should be performed, tested and validated after each repositioning process to ensure accuracy.

1. Set the robot in a transport position by referring to the joint positions below.

Joint	Position
Base	-63°
Shoulder	-200°
Elbow	-125°
Wrist 1	90°
Wrist 2	90°
Wrist 3	90°

2. Disconnect the power and pneumatic supplies as well as any other cabling that may interfere with the movement of the Solution.
3. Place the teach pendant on its rack at the operator station, or place it on the support rack of the robot's control box and run the teach pendant cable on the base of the Solution.



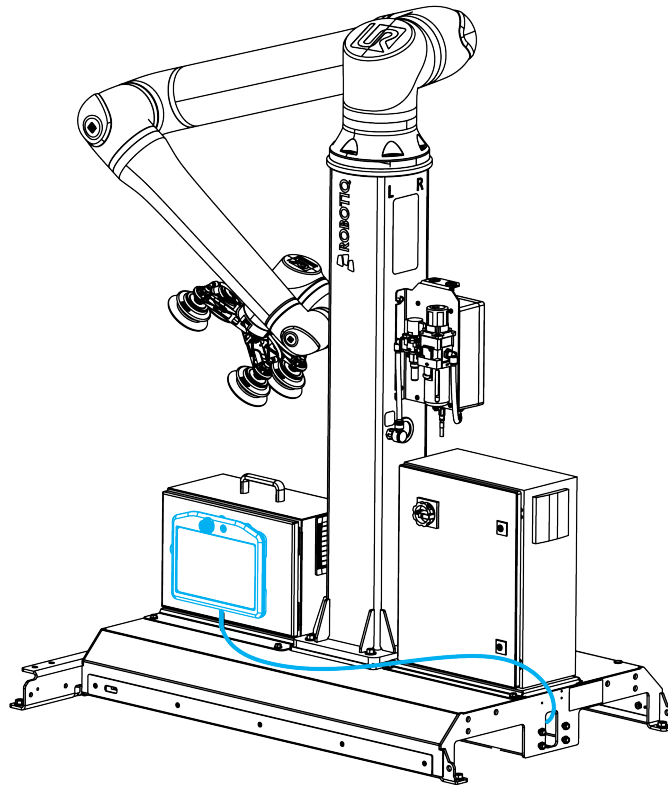

4. Unscrew the four (4) anchor nuts and keep them for future use.
5. If the Solution is attached to a conveyor, disassemble the attachment.
6. Insert the forks of the pallet truck or forklift truck in the fork entry openings until they stop. Make sure that the teach pendant cable or any other cable located at the front of the solution is not pinched during this operation.
7. Slightly raise the forks so that the Solution is freed from the anchors.
8. Slowly and carefully move the Solution, making sure the Solution remains close to the ground.
9. Perform the steps backwards to reposition the Solution; please refer to **Anchoring the Solution** section to apply the right torque.

NOTICE

To perform an accurate repositioning using this method, use the clearance holes located on the removable stopper (see figure below) to attach the Solution to a conveyor or another piece of equipment. Please refer to **Conveyor Positioning Holes** section for hole dimensions.

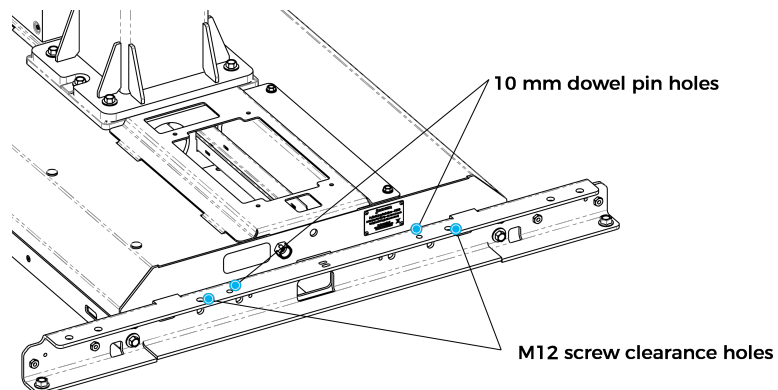

4.5.2. Accurate Repositioning (Against Anchored Down Removable Stopper)

The following method allows for a precise repositioning of the Solution, and should be used for the frequent moving of the Solution.

1. Set the robot in a transport position by referring to the joint positions below.

Joint	Position
Base	-63°
Shoulder	-200°
Elbow	-125°
Wrist 1	90°
Wrist 2	90°
Wrist 3	90°

2. Disconnect the power and pneumatic supplies as well as any other cabling that may interfere with the movement of the Solution.
3. Place the teach pendant on its rack at the operator station, or place it on the support rack of the robot's control box and run the teach pendant cable on the base of the Solution.

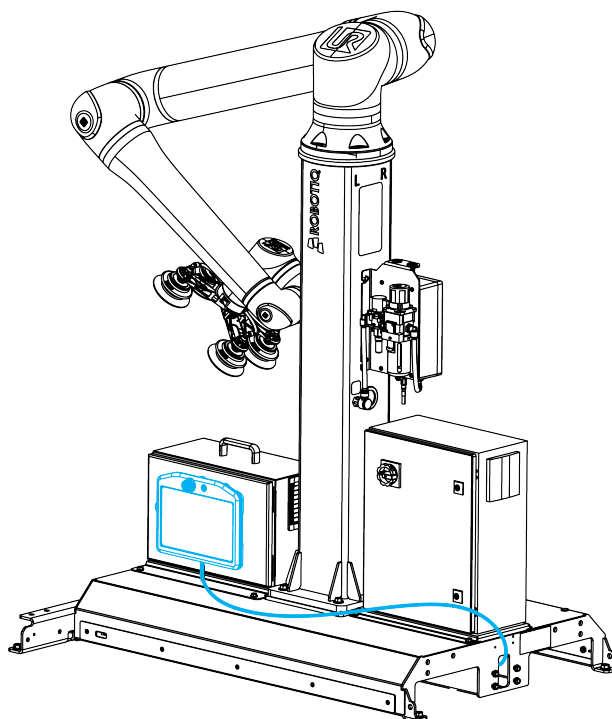

4. Unscrew the two (2) anchor nuts on the aisle side and keep them for future use.



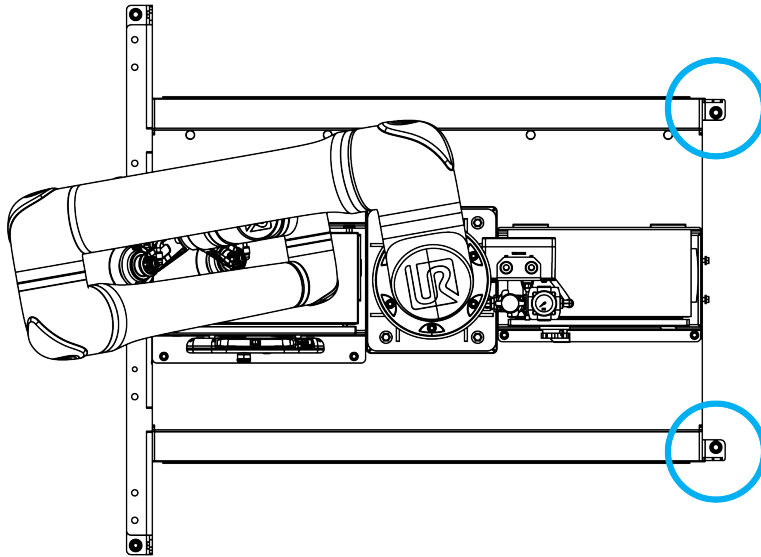

5. Insert the forks of the pallet truck or forklift truck in the fork entry openings until they stop. Make sure that the teach pendant cable or any other cable located at the front of the solution is not pinched during this operation.
6. Unscrew the four (4) bolts that hold the removable stopper to the base of the Solution.

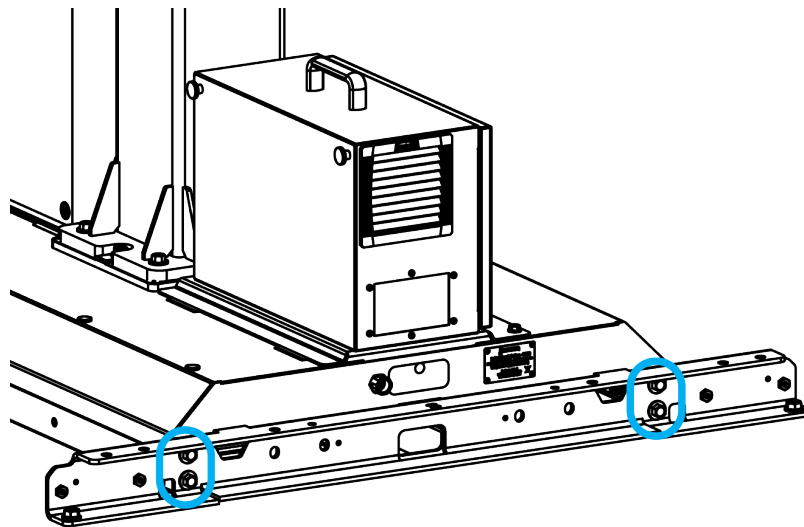

7. Insert the four bolts in the clearance holes on the top surface of the removable stopper.

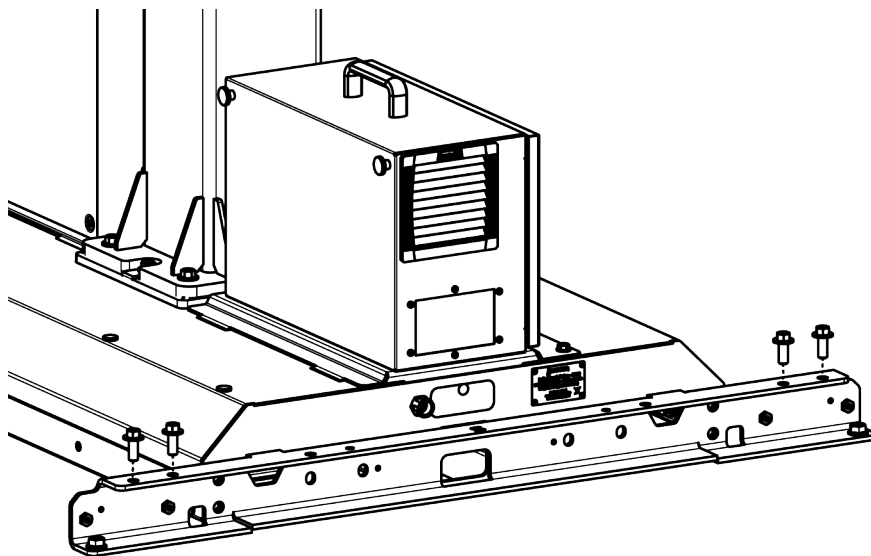

8. Slightly raise the forks so that the Solution is freed from the anchors.
9. Slowly and carefully move the Solution, making sure the Solution remains close to the ground.
10. Reposition the Solution back to its original place using the tabs of the removable stopper as guides.

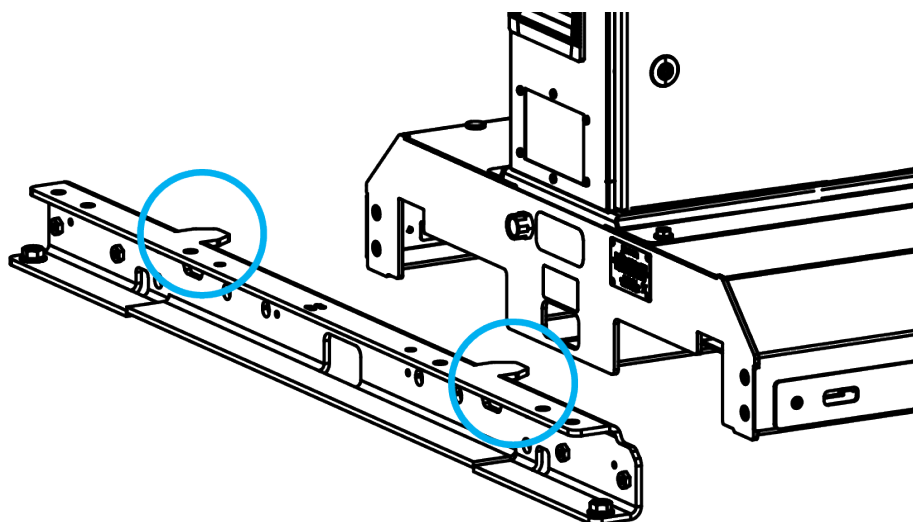

11. Perform steps 1 to 8 backwards (8 to 1) to secure the Solution. Please refer to the **Pedestal Installation** section to apply the right torque on the nuts of the removable stopper's anchors.



5. URCap Software

5.1. License Agreement

END-USER LICENSE AGREEMENT

YOU SHOULD CAREFULLY READ THE FOLLOWING AGREEMENT BEFORE USING THE Software (as this term is hereinafter defined). Using the Software indicates your acceptance of the agreement. If you do not agree with it, you are not authorized to use the Software.

IMPORTANT-READ CAREFULLY: This End-User License Agreement (the *Agreement*) is a legal agreement between you and the Licensor (as this term is hereinafter defined), the licensor of the Software. This Agreement covers the Software. The Software includes any *on-line* or electronic documentation and all modifications and upgrades related thereto. By installing, or otherwise using the Software, you agree to be bound by the terms of this Agreement. If you do not agree to the terms of this Agreement, the Licensor cannot and does not license the Software to you. In such event, you must not use or install the Software.

1. Definition.

1. *UR* means Universal Robots A/S, a corporation incorporated under the laws of Denmark, having its registered office at Energivej 25, DK-5260 Odense S, which specializes into the conception, advanced manufacturing and sale of robotic products (the *UR's Business*);
2. *Software* means any of the Licensor's softwares provided to its customers for the purposes mentioned in Sub-section 1.4 hereof including their modifications and upgrades and their related materials;
3. *Licensor* means Robotiq inc., a corporation incorporated under the laws of Quebec, having its registered office at 500-966 chemin Olivier, Lévis, Québec, Canada, G7A 2N1, which specializes into the conception, advanced manufacturing and sale of robotic products (the *Licensor's Business*);
4. *End-User* means a customer authorized pursuant to this Agreement to install or use the Software in order to make a specific product from the Licensor's Products compatible and functional with a specific product of the UR's Product;
5. *Licensor's Products* means those products developed by the Licensor in the course of the Licensor's Business;
6. *UR's Products* means those products developed by UR in the course of the UR's Business;
7. *Licensor's Authorized Representatives* means and includes the Licensor and Licensor's authorized vendors, resellers, distributors and licensors;
8. *Purchase Agreement* means an agreement between the End-User and the Licensor pursuant to which the End-User purchased one or more of the Licensor's Products.

2. **License.** Subject to the terms and conditions hereof, the Licensor grants to the End-User a personal, temporary, non-exclusive, non-assignable and non-transferable and revocable license to use the Software in accordance with the terms and conditions hereof.
3. **Software and Documentation.** The Licensor may provide, if applicable, all documentation containing the detailed specifications for operation and use of the Software, which Software shall be used in accordance with such documentation. This documentation, if applicable, will be provided, wholly or in part, within (i) this Agreement, (ii) the Licensor's Web site <http://robotiq.com/> (iii) the Licensor's Products and the Purchase Agreement therewith, or (iv) any other agreement, document, support, whatsoever decided by the Licensor.

The use of the Software requires the Licensor's Products, UR's Products, compatible systems and certain software (which may require some expenses), may require periodical updating and may be affected by such elements. Most equipment will be compatible with the Software. However, the Software may not function on certain types of equipment.



4. **Modifications and Upgrades.** The Licensor shall be under no obligation to provide any upgrade or modification to the Software. However, the End-User shall be entitled to receive free of charge all modifications and upgrades of the Software provided by the Licensor if, at such time, the End-User is not in default in respect of any of its obligation contained herein. Such modifications and upgrades of the Software shall be installed by the End-User itself by consulting the Licensor's Website <http://robotiq.com/> where a link to proceed to such installation will be made available thereof. A new version of the Software shall not be covered by this Section 4 but shall require that a new End-User Software License Agreement be entered into between the Licensor and the End-User.
5. **Fees.** The grant by Licensor to the End-User of the present license shall be free to the extent that the End-User agrees and complies to the term and conditions herein at all time.
6. **Maintenance.** During the term of this Agreement, the Licensor will maintain the Software in an operable condition and will make available any corrections and improvements as are generally incorporated in the Software by the Licensor without additional charge to the End-User. The Licensor may temporarily and without notice suspend or limit access to the Software if necessary or desirable in order to maintain, restore, modify or repair any part of the Software or for any reason related to business. During such works, the Software will not be available but the Licensor undertakes to deploy its best efforts to perform such works at appropriate times and to limit any inconvenience arising therefrom.
7. **Title to Software.** The licensed Software is composed of confidential data and trade secrets and is proprietary to and constitutes trade secret information and intellectual property of the Licensor. Title and ownership rights to the Software, including the intellectual property rights related thereto, shall remain with the Licensor. The End-User agrees to maintain the confidential nature of the Software and related materials provided for the End-User's own internal use under this Agreement. The license granted herein does not include the right to sublicense to others, and may not be assigned to others, in whole or in part, without the prior written consent of the Licensor. The End-User may not or allow others to modify or prepare directive works, copy (except for normal backups for recovery purposes), reproduce, republish, reverse engineer, upload, post, transmit, or distribute, in any manner, the Software.
8. **Restricted Use.** The Software shall be used solely and exclusively by the End-User and its employees for the purpose mentioned in Sub-section 1.4 hereof. Any other use of the Software, including resell derivative modifications or extensions, is expressly prohibited.
9. **Exclusion of Warranty on Software.** The End-User expressly acknowledges and agrees that use of the Software is at the End-User sole risk. The Software is provided "AS IS" and without warranty of any kind. THE LICENSOR AND THE LICENSOR'S AUTHORIZED REPRESENTATIVES DO NOT WARRANT THAT Software WILL BE FREE OF ERRORS AND YOU ACKNOWLEDGE THAT THE EXISTENCE OF ANY SUCH ERRORS DOES NOT CONSTITUTE A BREACH OF THIS AGREEMENT. TO THE EXTENT PERMITTED BY LAW LICENSOR AND LICENSOR'S AUTHORIZED REPRESENTATIVES EXPRESSLY DISCLAIM ALL WARRANTIES, EXPRESS OR IMPLIED, INCLUDING , BUT NOT LIMITED TO, THE IMPLIED WARRANTIES OF MERCHANTABILITY AND FITNESS FOR A PARTICULAR PURPOSE UNLESS OTHERWISE STATED HEREIN. LICENSOR AND LICENSOR'S AUTHORIZED REPRESENTATIVES DO NOT WARRANT THAT THE FUNCTIONS CONTAINED IN THE Software WILL MEET THE END-USER REQUIREMENTS OR THAT THE OPERATION OF THE Software WILL BE CORRECT. FURTHERMORE, LICENSOR AND LICENSOR'S AUTHORIZED REPRESENTATIVES DO NOT WARRANT OR MAKE ANY REPRESENTATIONS REGARDING THE USE OR THE RESULTS OF THE USE OF THE Software IN TERMS OF ITS CORRECTNESS, ACCURACY, RELIABILITY, OR OTHERWISE. NO ORAL OR WRITTEN INFORMATION OR ADVICE GIVEN BY LICENSOR AND LICENSOR'S AUTHORIZED REPRESENTATIVE SHALL CREATE A WARRANTY OR IN ANY WAY INCREASE THE SCOPE OF THIS WARRANTY. SHOULD THE Software PROVE DEFECTIVE IN YOUR TECHNOLOGY ENVIRONMENT, YOU ASSUME THE ENTIRE COST OF ALL NECESSARY SERVICING, REPAIR OR CORRECTION TO YOUR OWN TECHNOLOGY ENVIRONMENT.
10. **Limitation of liability.** TO THE MAXIMUM EXTENT PERMITTED BY LAW, LICENSOR AND LICENSOR'S AUTHORIZED REPRESENTATIVES SHALL NOT BE LIABLE FOR ANY INCIDENTAL OR CONSEQUENTIAL DAMAGES FOR BREACH OF ANY EXPRESS OR IMPLIED WARRANTY, BREACH OF CONTRACT, NEGLIGENCE, STRICT LIABILITY OR ANY OTHER LEGAL THEORY RELATED TO THE Software. SUCH DAMAGES INCLUDE, BUT ARE NOT LIMITED TO, LOSS OF PROFITS, LOSS OF REVENUE, LOSS OF DATA, LOSS OF USE OF THE PRODUCT OR ANY ASSOCIATED EQUIPMENT, DOWN TIME AND USER'S TIME, EVEN IF THE LICENSOR HAS BEEN ADVISED OF THE POSSIBILITY OF SUCH DAMAGES. IN ANY CASE, LICENSOR ENTIRE LIABILITY UNDER ANY PROVISION OF THIS AGREEMENT SHALL BE LIMITED TO THE AMOUNT ACTUALLY PAID IN RESPECT OF THE LICENSOR'S PRODUCTS PURCHASED BY THE END-USER PURSUANT TO A PURCHASE AGREEMENT.
11. **Training, Maintenance and Support** There is no entitlement to training, maintenance and support under this license unless otherwise specified in the Purchase Agreement or any other written agreement between the End-User and the Licensor. The



End-User may provide the Licensor with details regarding any bug, defect or failure in the Software promptly and with no delay from such event; the End-User shall comply with the Licensor's request for information regarding bugs, defects or failures and furnish him with information, screenshots and try to reproduce such bugs, defects or failures upon Licensor's demand.

12. Expiration and Termination. The Licensor may terminate this Agreement for default by the End-User. This Agreement will also be automatically terminated upon the election of such by the Licensor or the official launch of the Software, whichever event comes first. Upon termination of this Agreement for any reason, the End-User shall promptly uninstall the Software on any UR's Products and Licensor's Products, computer, or server on which it has been installed, deliver to the Licensor all CDs, DVDs, magnetic tapes, cards, and other tangible items and materials embodying the Software, and return to the Licensor all copies thereof or destroy such copies and warrant in writing that all copies thereof have been destroyed. In the event of termination of this Agreement, all obligations of the parties under this Agreement due for performance on the date of termination shall survive the termination, and the party terminating shall not be liable to the other party for any damages arising out of the termination.
13. Miscellaneous.
 1. This Agreement constitutes the entire understanding and agreement between the Licensor and the End-User and replaces any prior agreement relating to the same subject matter.
 2. This Agreement shall be governed and construed in accordance with the laws of the province of Quebec and the federal laws of Canada applicable therein. Any legal action or proceeding between the Licensor and the End-User for any purpose concerning this Agreement or the parties' obligations hereunder shall be brought exclusively in a court of competent jurisdiction sitting in the judicial district of Trois-Rivières, Quebec.
 3. The Licensor's failure to insist upon or enforce strict performance of any provision of this Agreement shall not be construed as a waiver of any provision or right. Neither the course of conduct between the parties nor trade practice shall act to modify any provision of this Agreement.
 4. The Licensor may assign its rights and duties under this Agreement to any party at any time without notice to the End-User. The End-User may not assign this Agreement without the prior written consent of the Licensor.
 5. If any part of this Agreement is null, illegal or non-enforceable, this Agreement shall be interpreted as if this part was never part of this Agreement.
 6. The provisions of this Agreement are for the benefit of the Licensor and its officers, directors, employees, agents, licensors and suppliers. Each of these individuals or entities shall have the right to assert and enforce those provisions directly against the End-User on its own behalf. This Agreement is also for the benefit of, and binds, the End-User and its heirs, successors, legal representatives and permitted assigns.
 7. Any rights not expressly granted herein are reserved.
 8. The parties confirm that they have agreed that this Agreement and all related documents be drafted in English only. Les parties aux présentes confirment qu'elles ont accepté que la présente convention et tous les documents y afférents soient rédigés en anglais seulement.



5.2. Copilot



CAUTION

To ensure the normal operation of the Solution, make sure the Copilot license dongle remains connected at all times.

1. Connect the license dongle to the USB hub in the UR control box.
2. Go to **Installation > URCaps > Copilot > Dashboard** to ensure your Copilot license is activated.

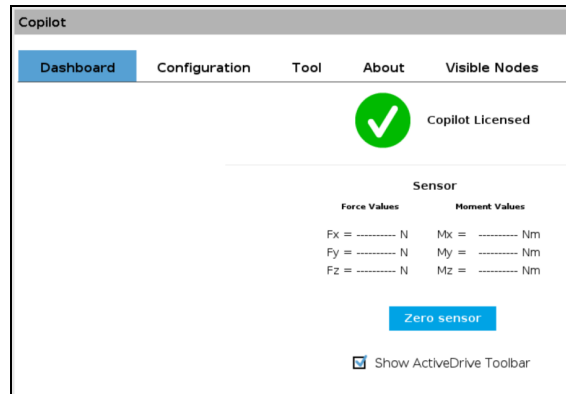

Fig. 5-1: Copilot License

3. Select the Palletizer model:

Tap **Installation > URCaps > Copilot > Configuration > PE Series** radio button. When selecting the PE20, the pedestal height is automatically set at 1400 mm.

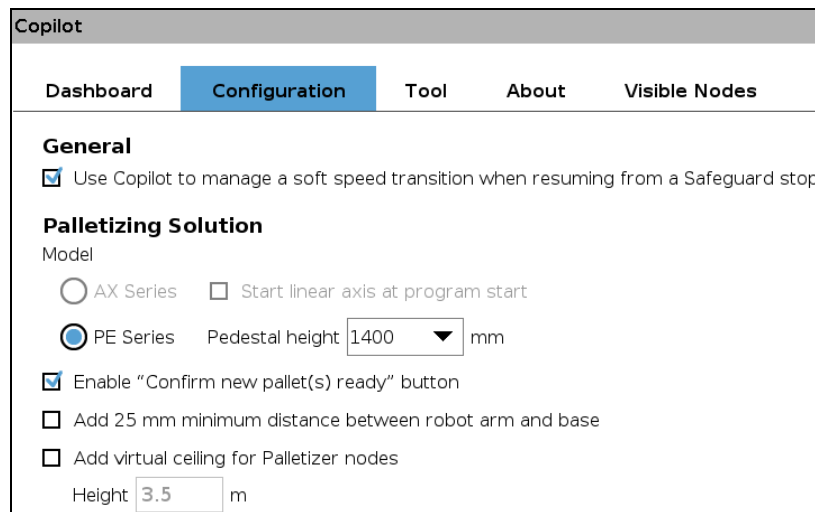

Fig. 5-2: Copilot Configuration Tab in the Installation Menu





NOTICE- Speed Slider



Robotiq recommends to keep Copilot activated at all times.

However, if another URCap or PolyScope option (for instance, ProfiNET or Ethernet/IP) needs to take control of the speed slider, the option **Use Copilot to manage a soft speed transition when resuming from a Safeguard position** can be deactivated.



4. If required, select the **Enable "Confirm new pallet(s) ready" button** option. This feature allows the user to use the **Confirm new pallet(s) ready** button found on the push button enclosure. This prevents the Palletizer from palletizing on a new pallet detected by the pallet sensors. In order to start the palletization on that new pallet, the operator has to press the **Confirm new pallet(s) ready** button.
5. If required, select the **Add 25 mm minimum distance between robot arm and base** option. When selected, this feature ensures a 25 mm clearance between the moving parts and the fundamental components of the base of the Solution (both control boxes, teach pendant holders and mounting zone for pneumatic accessories) during trajectory execution.
6. If required, select the **Add base height offset for Palletizer node** option. Note that only the base will be offset, and not the actual pallet(s). Only use this feature if recommended by Robotiq for the application at hand.

	 CAUTION
	<p>When adding moves other than those generated automatically by the Palletizer node, it is the responsibility of the user to observe the 25 mm minimum distance at all times.</p> <p>This option can influence box throughput and affect the furthest positions reachable by the robot end effector. It should only be used in situations where it is strictly necessary.</p>

	 CAUTION
	<p>Make sure to observe sufficient clearance between any overhead equipment or ceiling, and the components of the Palletizing Solution.</p> <p>If required, activate the Add virtual ceiling for Palletizer nodes option.</p> <p>Enter the height limitation.</p> <p>This will prevent the components of the Palletizing Solution from extending beyond this limit when in motion.</p>

5.3. Command Window

5.3.1. Palletizer Node

1. Tap **Program > URCaps > Palletizer** to add a Palletizer node in the robot program.
2. In the **Command** window, tap the **Start** button. The interface will display the Box, Pallet, Pattern and Settings blocks.



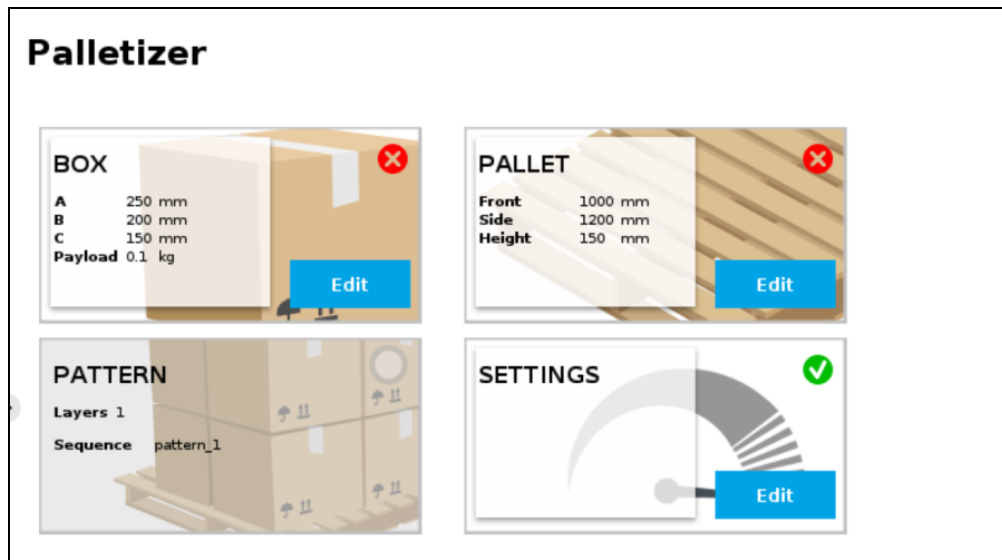

Fig. 5-3: Home View of a New Palletizer Node

3. Tap the **Edit** button in the **Settings** block.

Settings Block

Settings Menu

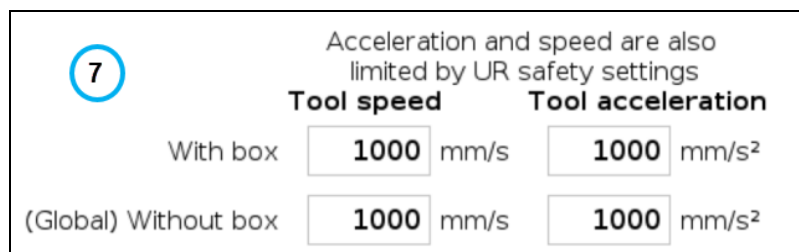
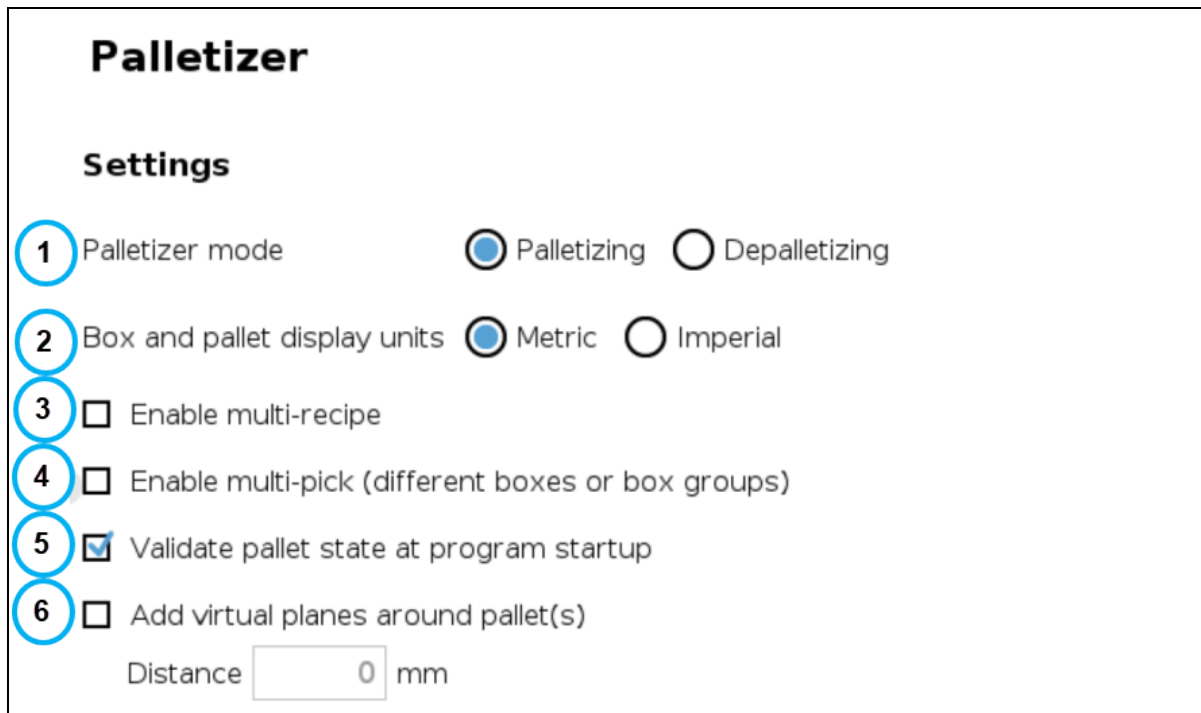

Fig. 5-4: Settings Menu of a Palletizer Node



1. Palletizer mode

Select the radio button that corresponds to the task to be performed, either **Palletizing** or **Depalletizing**. The default value is Palletizing.

2. Box and pallet display units

Select the preferred measurement system, either **Metric** or **Imperial**. The default value is Metric.

3. Enable multi-recipe

Disabled by default.

Tick the box to enable multi-recipe.

The multi-recipe feature adds the ability to create one or more palletizing recipes within the same Palletizer node, each with its own layer sequence, number of layers, patterns, box types, and settings.



NOTICE

Once enabled, the multi-recipe feature applies to the entire Palletizer node.

The interface thus displays a visual indicator signaling the user that changes made to certain sections of the Settings menu will affect the entire Palletizer node.

Palletizer

Settings

Global (for all recipes in this Palletizer node)

Palletizer mode Palletizing Depalletizing

Box and pallet display units Metric Imperial

Enable multi-recipe

Enable multi-pick (different boxes or box groups)

Validate pallet state at program startup

Add virtual planes around pallet(s)

Distance mm

Fig. 5-5: Settings Menu of a Palletizer Node - Global Settings





NOTICE

When enabled, the multi-recipe feature changes the home view of the Palletizer node and displays the list of palletizing recipes.

4. Enable multi-pick (different boxes or box groups)

Disabled by default.

The multi-pick feature allows for the configuration of different box types.

It can be used in contexts such as:

- Retrieving different box types from different picking locations;
- Retrieving multiple identical boxes simultaneously (i.e., at the same picking location) using one or several grippers.



NOTICE

- Boxes picked together are considered and handled as one unit by the system.
- Boxes to be picked together must be right next to each other at the same picking location (e.g., at the end of a conveyor).
- Boxes picked together must be dropped right next to each other at the same drop location (e.g., on a pallet layer).
- Boxes picked together must have the **same dimensions**.
- Boxes picked together must have the **same payload**.

Refer to the **Box Sensor (Multiple Box Types - Multi-Pick Feature)** section to perform the wiring procedure (hardware step) of the multi-pick feature, and to the **Palletizer Node With Multi-Pick Feature** section for information on how to program using the multi-pick feature (software steps).

5. Validate pallet state at program startup

Enabled by default.

When this option is activated, the system will bring up a pop-up window (i.e., the **Pallet viewer**) for each Palletizer node, and will prompt the user to confirm each pallet's state at the start of the program, either empty, full, absent or ignored.

Untick to deactivate if required. When this option is not selected, the system will not bring up a pop-up window to confirm each pallet's state at the start of the robot program.

- If the Palletizer is set in palletizing mode, the pallet will be considered empty.
- If the Palletizer is set in depalletizing mode, the pallet will be considered full.
- If the pallet sensors do not detect the presence of a pallet, the pallet will be considered absent.





CAUTION

If, for whatever reason, the Pallet viewer indicates that a pallet is absent although it is materially present, it is the responsibility of the user to confirm the actual state of the pallet, either full, empty or ignored.



CAUTION

When the user is not given the option to validate the pallet state at the start of the program:

- If the program stops, the current state (i.e., number of boxes processed) of each pallet will be kept in memory.
- Saving the robot program also saves the current state (i.e., number of boxes processed) of each pallet. Loading the program will also load the saved pallet state.
- The Palletizer node will thus resume with the saved pallet state.

6. Add virtual planes around pallet(s)

Disabled by default.

When enabled, this option unlocks the **Distance** field to enter a numerical value. This value will add to the measurement of each pallet side to create a virtual plane around it. This prevents the robot holding boxes, and the actual boxes, from reaching beyond the limits of the virtual plane.

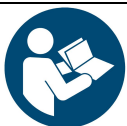

NOTICE

Robotiq recommends keeping a minimum distance of 50 mm (2 in) around all pallet sides.

7. Tool speed and Tool acceleration

Set the speed and acceleration of the end-of-arm tooling for:

- When it carries a load (**With box**)
- When it moves without carrying a load (**Without box**)



CAUTION

When the multi-recipe feature is enabled, the With box values are specific to the recipe being edited, and the **Without box values apply to the entire Palletizer node** (i.e., all recipes of the node).

This way, the end-of-arm tooling will travel at different speeds and accelerations depending on the type of box it carries, but will always travel at the same speed and acceleration when not carrying a load.



Home View

Single Recipe

By default (**single recipe**), the home view of the Palletizer node displays the Box, Pallet, Pattern and Settings blocks of the only recipe available.

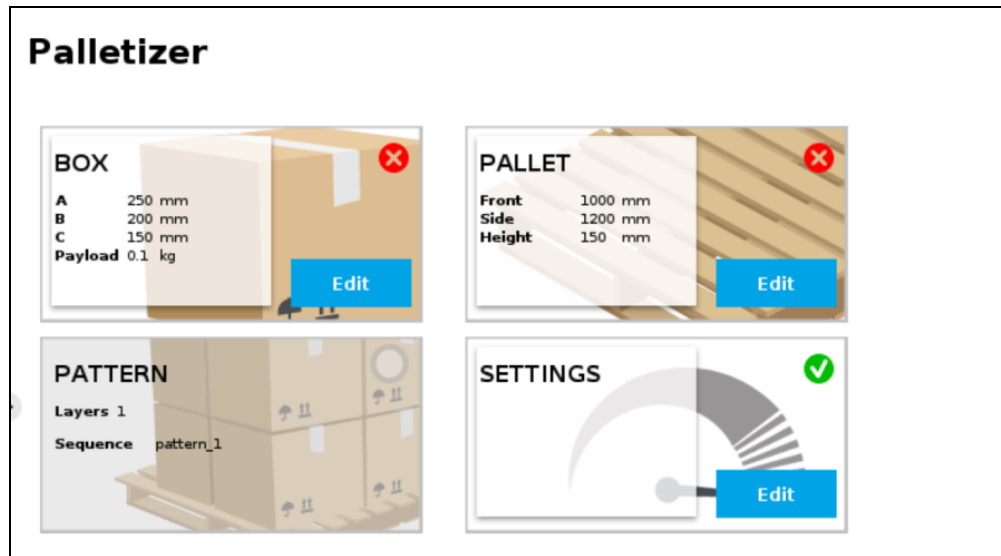

Fig. 5-6: Home View of a Single Recipe Palletizer Node (Dashboard)

Multi-Recipe

When the **multi-recipe** feature is enabled, the home view of the Palletizer node displays the list of recipes created.

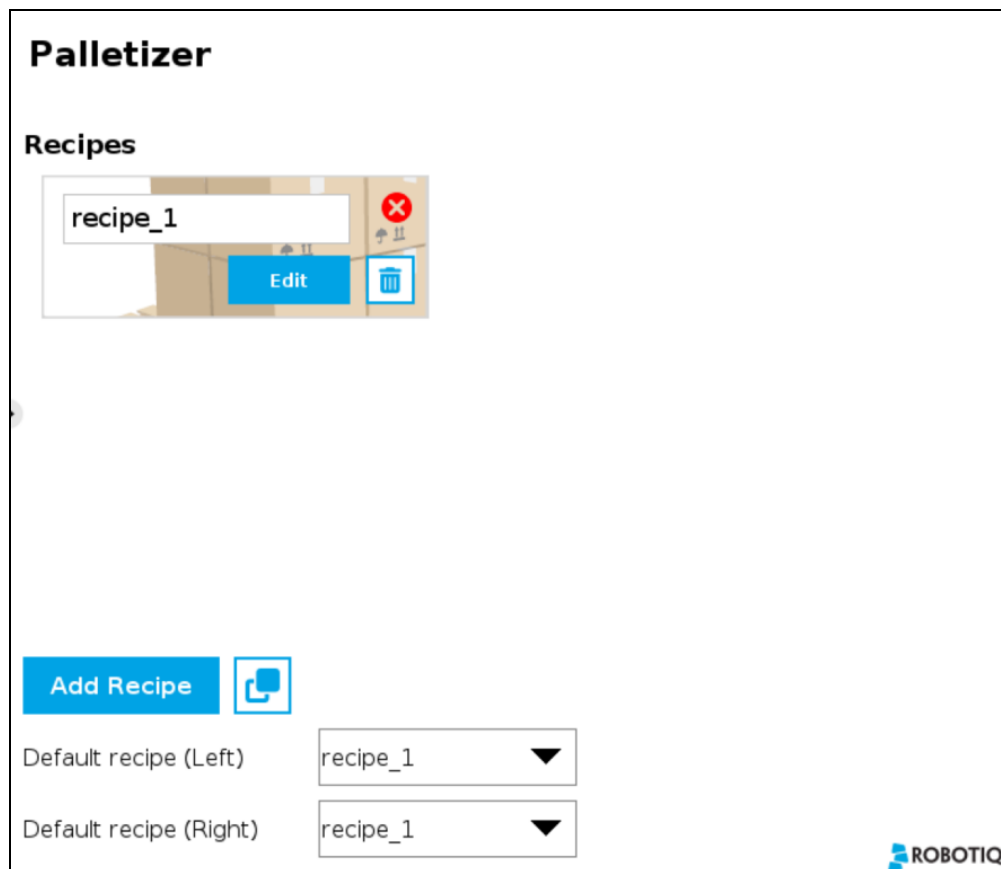



Fig. 5-7: Home View of a Multi-Recipe Palletizer Node



- Tap the **Add Recipe** button to create a new pallet recipe, yet to be configured.
- The **Default recipe dropdown menus** allow the user to select which recipes will be used at the start of the robot program.
- When starting the program, choose which recipe will be used for each pallet in the **Confirm current pallet state** popup window.

NOTICE	
	<p>The recipe selected from the dropdown menu in the upper right corner will change the recipe for both pallets.</p> <p>The recipe selected from the dropdown menu in the lower right corner will change the recipe for the other pallet only.</p>

Confirm current pallet state - LEFT - Palletizing recipe_1 ▼

recipe_1
 recipe_2

+
Add box

-
Remove box

Reset

Next step :
Before pallet

Confirm other pallet state - RIGHT

 Empty
 Full
 Absent
 Ignored

recipe_1 ▼

Ok
Cancel

Confirm current pallet state - LEFT - Palletizing recipe_2 ▼

+
Add box

-
Remove box

Reset

Next step :
Before pallet

Confirm other pallet state - RIGHT

 Empty
 Full
 Absent
 Ignored

recipe_2 ▼

Ok
Cancel

Confirm current pallet state - LEFT - Palletizing recipe_2 ▼

+
Add box

-
Remove box

Reset

Next step :
Before pallet

Confirm other pallet state - RIGHT

 Empty
 Full
 Absent
 Ignored

recipe_1 ▼

recipe_1
 recipe_2

Ok
Cancel

Confirm current pallet state - LEFT - Palletizing recipe_2 ▼

+
Add box

-
Remove box

Reset

Next step :
Before pallet

Confirm other pallet state - RIGHT

 Empty
 Full
 Absent
 Ignored

recipe_1 ▼

Ok
Cancel

- If applicable, tap the **Duplicate** icon  to open the duplication menu.





Palletizer

Duplicate Recipe

Duplicate this recipe

Save as

Fig. 5-8: Duplicate Recipe Menu

- If required, duplicate a recipe and tap the **OK** button, or tap **Cancel** to go back to the list of recipes.
- Tap the **Edit** button under the name of a recipe to bring up the Box, Pallet, Pattern and Settings blocks specific to the recipe to edit.

Box Block

Single Pick (Default Mode)

By default (single pick), the home view of the Palletizer node displays the Box, Pallet, Pattern and Settings blocks of the only recipe available.

Tap the **Edit** button in the Box block to bring up the **Box menu**.

Multi-Pick (Different Boxes or Box Groups)

By default, the multi-pick feature is disabled in the **Settings** menu.

When the multi-pick feature is enabled in the **Settings** menu, selecting the Box block brings up the Box Types menu (i.e., the list of box types created).



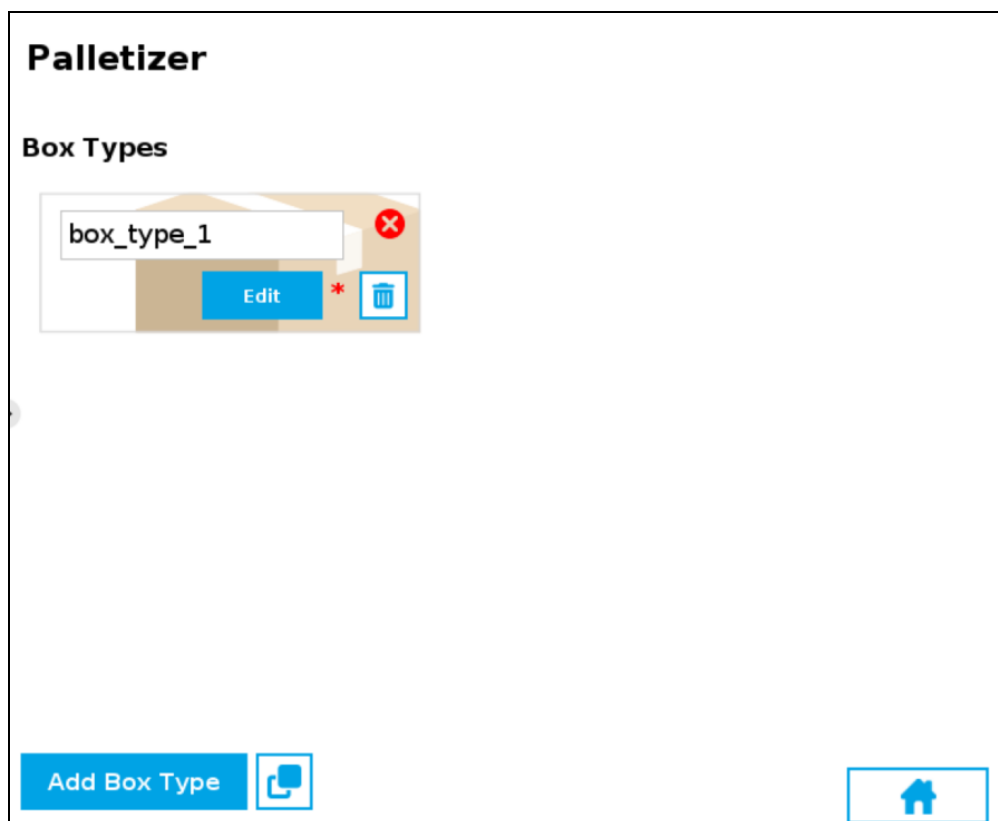

Fig. 5-9: Box Type Menu (Multi-Pick Feature)

- If applicable, tap the **Add Box Type** button to create a new box type, yet to be configured.



- If applicable, tap the **Duplicate** icon to open the duplication menu.

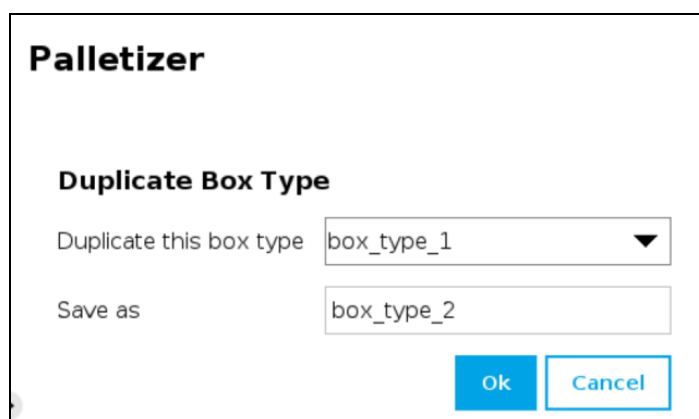
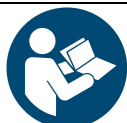

Fig. 5-10: Duplicate Box Type Menu

- Duplicate a box type and tap the **OK** button, or tap **Cancel** to go back to the Box Type menu.



NOTICE

Rename the box types in a manner that will prevent confusion (e.g., single_box, double_box, triple_box).



**CAUTION**

Make sure the box type name you enter is devoid of spaces; failing to do so will prevent the program tree from calling the box type.

- Tap the **Edit** button under the name of a box type to bring up the **Box menu**.



Box Menu

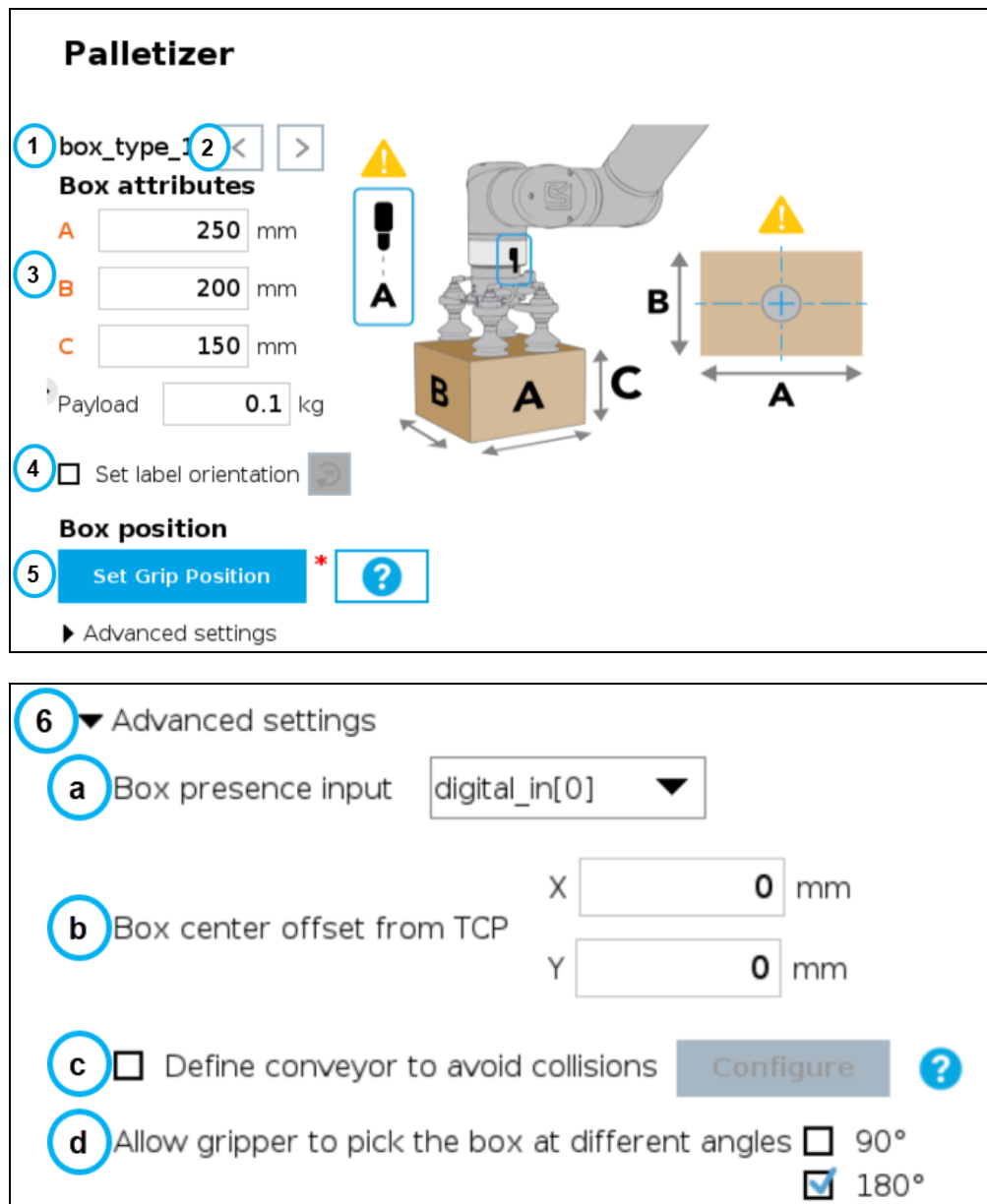

Fig. 5-11: Box Menu of a Palletizer Node

1. Box type name (Multi-Pick)

If the multi-pick feature has been enabled in the Settings menu, the Box menu will display the name of the selected box type above the Box attributes.

2. Box type toggle (Multi-Pick)

If the multi-pick feature has been enabled in the Settings menu, and if more than one box type has been created, the user will have the option to toggle between box types using the left and right arrows.

3. Box attributes

- Refer to the diagram and enter the length, width and height of the box in the corresponding fields.
- Enter the payload of the box in the corresponding field.



NOTICE

Best Practice - Multi-Pick Feature

Should the user need to pick **several identical boxes** using one or several grippers, Robotiq recommends the following:

- Create a first box type (i.e., standard box type) that corresponds to a single box unit.
- Duplicate the first box type.
- Edit the new box type:
 - Adjust the length or width so that it matches a multiple of that attribute (i.e., X2 for double the length OR width of the standard box, X3 for triple the length OR width of the standard box, and so on);
 - Adjust the payload so that it matches a multiple of that attribute (i.e., X2 for double the payload of the standard box, X3 for triple the payload of the standard box, and so on).



4. Set label orientation

If applicable, tick the **Set label orientation** box.

Doing so will display a label placeholder directly on one side of the box.

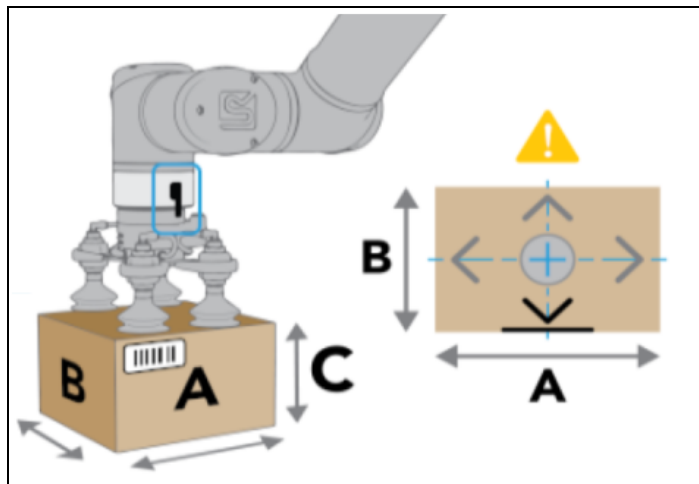

Fig. 5-12: Label Positioning on the "A" Side of the Box.

Tap the **Rotate 90°** button  to change the box side on which the label can be found in the actual production process.



Fig. 5-13: Different Label Positions



5. Box position

- **Set Grip Position / Set Drop Position**

Tap the **Set Grip Position** button (palletizing mode) or **Set Drop Position** button (depalletizing mode) to open the UR Move menu

Move the TCP to the position at which the gripper will pick up or drop the boxes (e.g., from/on a conveyor).

The TCP should be positioned **at the center of the top of the box** that needs to be picked or dropped.

	 CAUTION
	Position the robot wrist connector so that it is aligned with side A.

- Once the grip/drop position is defined, the Box menu will display the option to move to that position with the robot.

6. Advanced settings - Multi-Pick Feature

	NOTICE
	<p>Multi-Pick Feature</p> <p>The advanced settings are also available in the Settings menu, only if the multi-pick feature has already been enabled in the Settings menu.</p> <ul style="list-style-type: none"> • Single recipe > Settings Block > Edit • Multi-recipe > Select Recipe > Edit > Settings Block > Edit

a. Box presence input dropdown menu

Select the digital input to which the box presence sensor has been connected beforehand.

b. Box center offset from TCP (multi-pick feature only)



NOTICE

Best Practice - Multi-Pick Feature

Should the user want the gripper to offset the box center based on whether it picks a single box or a multiple of the single box:

- Measure the X and Y distances from the TCP to the target center on top of the box(es).
- Example 1: The TCP has been set at the center on top of two boxes combined; the robot can be instructed to offset the box center so that it corresponds to the target center on top of a single box.
- Example 2: The TCP has been set at the center on top of a single box; the robot can be instructed to offset the box center so that it corresponds to the target center on top of two boxes combined.
- Enter the X and Y values in the corresponding fields.

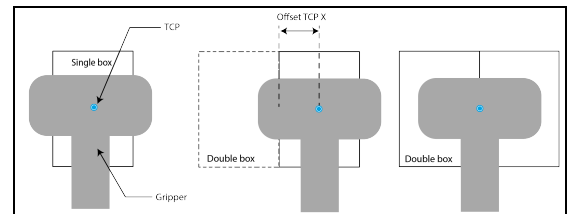
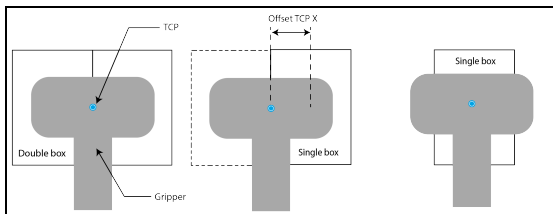

Fig. 5-14: Examples of Box Center Offset from TCP

c. Allow gripper to pick the box at different angles

In order to optimize the trajectory and travel of the robot arm during the palletizing or depalletizing process, the user can allow or prevent the gripper to pick up the boxes from different angles.

Tick or untick either box to allow or prevent the gripper from picking the boxes as if the robot wrist had performed a 90- or 180-degree rotation on the Z-axis.

When the multi-pick feature is disabled in the Settings menu, the System **defaults** to allowing the gripper to pick the boxes as if the robot wrist had performed a 90- or 180-degree rotation on the Z-axis.

When the multi-pick feature is enabled in the Settings menu, the system **defaults** to allowing the gripper to pick the boxes as if the robot wrist had performed a 180-degree rotation on the Z-axis.



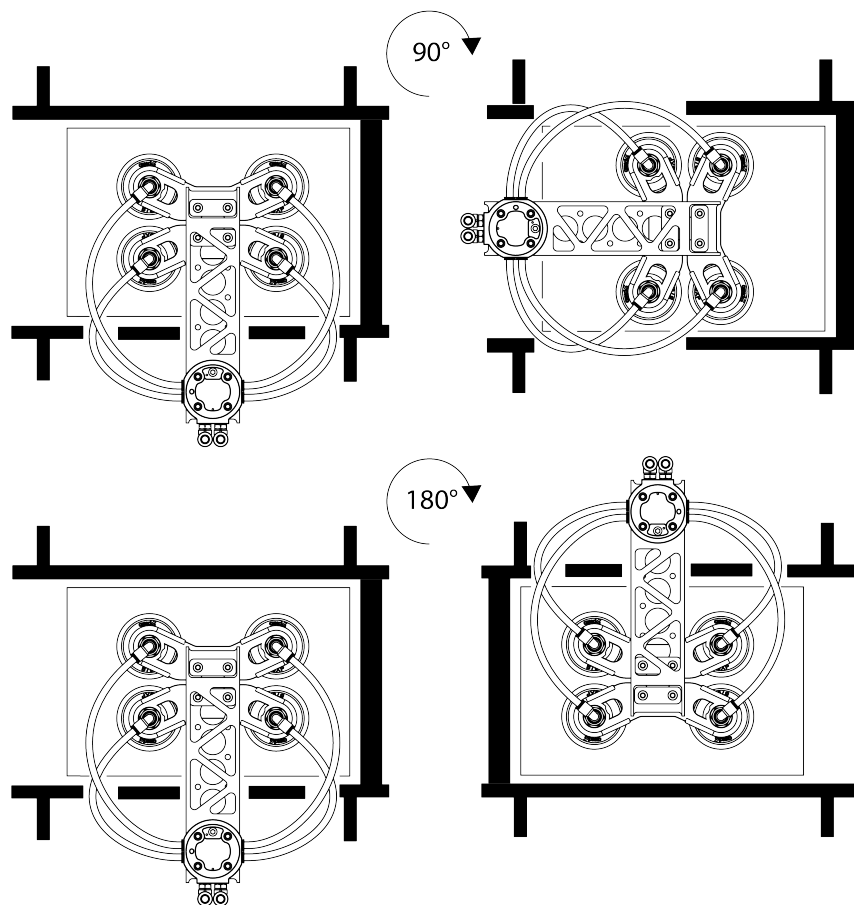

Fig. 5-15: Depiction of Gripper Rotations Based on the Option to Pick Up Boxes From Different Angles

d. Define conveyor to avoid collisions

Unticked by default.

Tick the box to unlock the **Configure** button.

Tapping the **Configure** button will bring up the **Conveyor** menu.

Conveyor Menu

Tick the radio button that corresponds to the palletizing cell (Perpendicular, Parallel, Custom).

Refer to the diagram on the interface and enter the corresponding values.



Palletizer

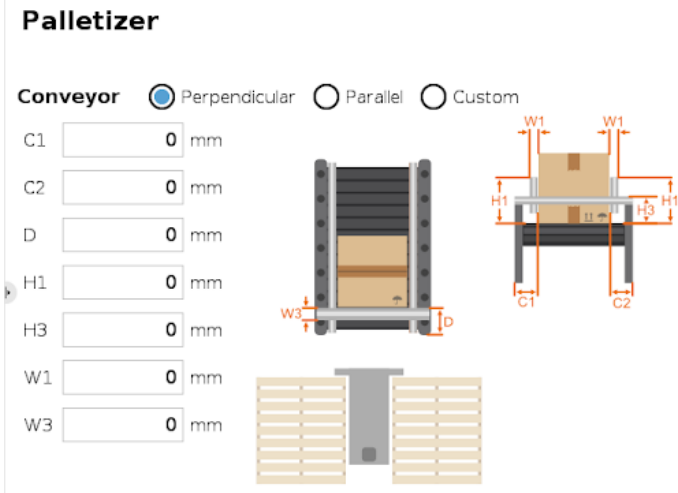

Fig. 5-16: Perpendicular Conveyor Configuration

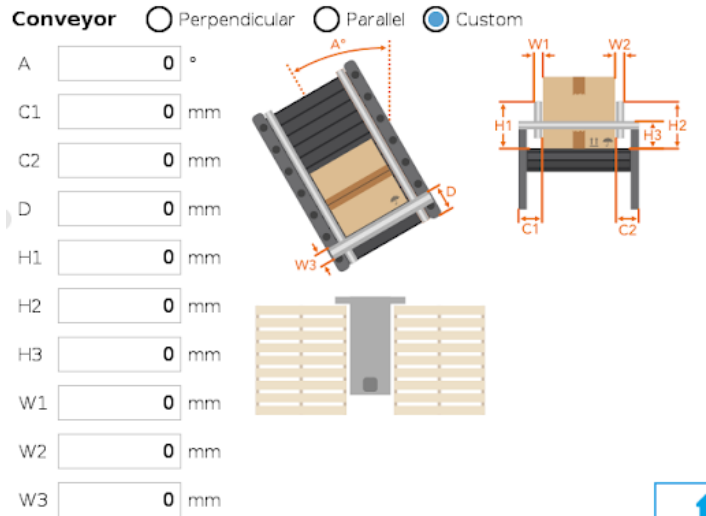

Fig. 5-17: Custom Conveyor Configuration

Palletizer

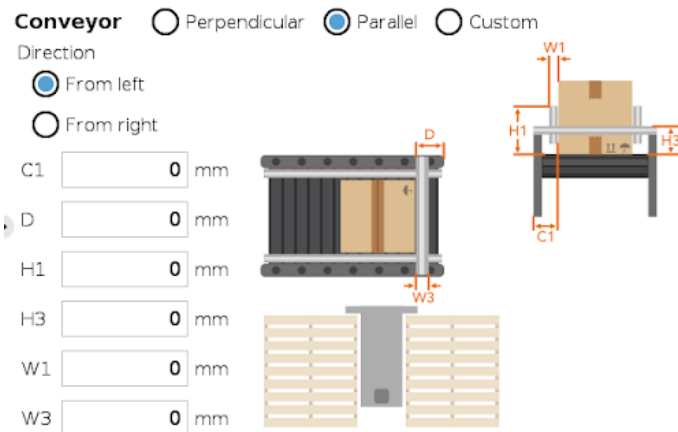

Fig. 5-18: Left-to-Right Parallel Conveyor Configuration

Palletizer

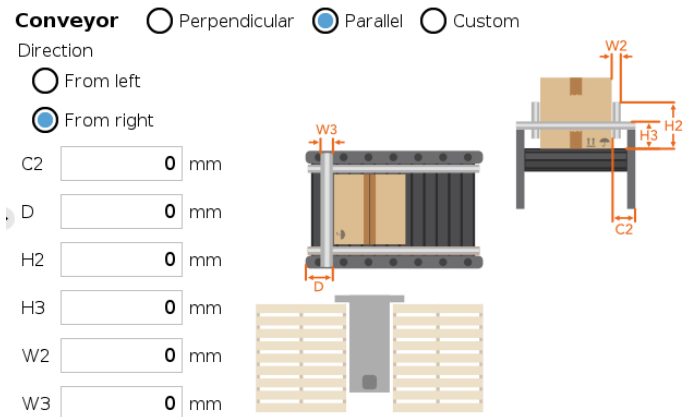

Fig. 5-19: Right-to-Left Parallel Conveyor Configuration

Pallet Block

Single Recipe

By default (**single recipe**), the home view of the Palletizer node displays the Box, Pallet, Pattern and Settings blocks of the only recipe available.

Tap the **Edit** button of the Pallet block to open the **Pallet menu**.

Multi-Recipe

When the **multi-recipe** feature is enabled, the home view of the Palletizer node displays the list of recipes created. Tap the **Edit** button under the name of a recipe to bring up the Box, Pallet, Pattern and Settings blocks specific to the recipe to edit.

Tap the **Edit** button of the Pallet block to open the **Pallet menu**.



Pallet Menu

Palletizer

Pallet dimensions

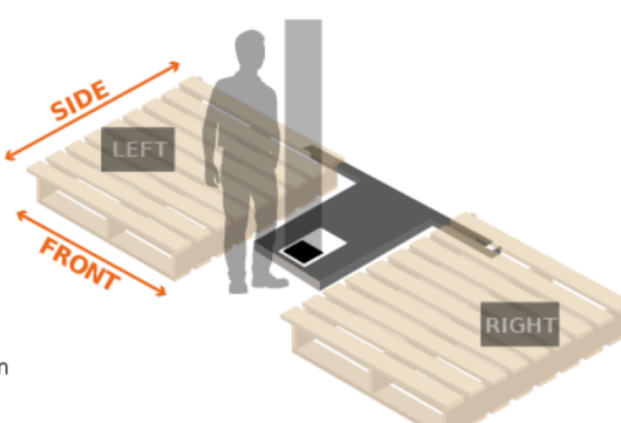

Front mm

1 Side mm

Height mm

Pallet selection *

2 LEFT

RIGHT

3 (Global, applies to all recipes in this Palletizer node) ?

Fig. 5-20: Pallet Menu

1. Pallet dimensions

Refer to the diagram and enter the front, side and height dimensions of the pallet.

2. Pallet selection

Both boxes are unticked by default.

It is the responsibility of the user to select the pallet(s) to process based on the application and layout of the palletizing cell.

Refer to the diagram and select which pallet (left and/or right) you want to palletize or depalletize. Tick both boxes to process both the left and right pallets.



NOTICE

Should the user unselect a pallet side (either left or right), that pallet will be ignored by the system (i.e., considered as if there was no pallet present, even if a pallet is detected by the pallet sensors).

3. Global callout (multi-recipe only)

If the multi-recipe feature has been enabled in the Settings menu, this callout will be shown.

It informs the user of the fact that the pallet(s) selected will be processed in all recipes of the Palletizer node.



Pattern Block



CAUTION

In order to edit pallet layer patterns, at least one pallet side has to be selected in the Pallet menu.

Single Recipe

By default (**single recipe**), the home view of the Palletizer node displays the Box, Pallet, Pattern and Settings blocks of the only recipe available.

Tap the **Edit** button of the Pattern block to open the **Pattern menu**.

Multi-Recipe

If the **multi-recipe** feature has been enabled in the Settings menu, the home view of the Palletizer node displays the list of recipes created.

Tap the **Edit** button under the name of a recipe to bring up the Box, Pallet, Pattern and Settings blocks specific to the recipe to edit.

Tap the **Edit** button of the Pattern block to open the **Pattern menu**.

Pattern Menu

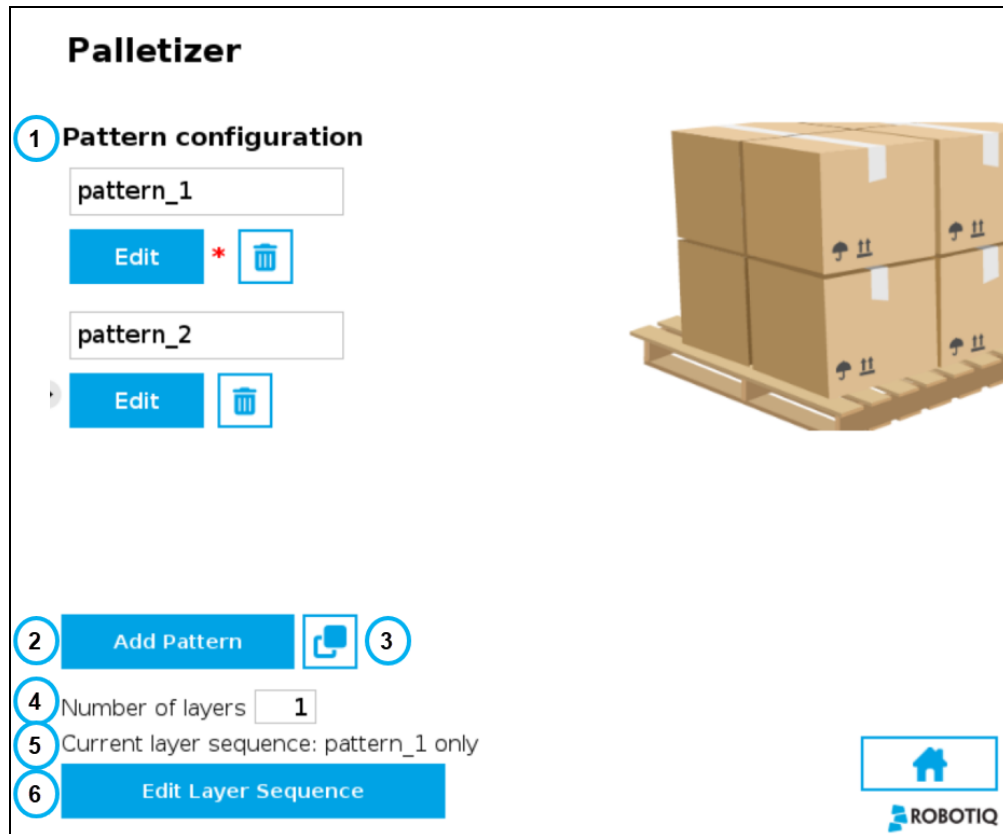

Fig. 5-21: Pattern Menu

1. Pattern configuration

This shows a list of available layer patterns.



By default, two (2) empty layer patterns are available (i.e., pattern_1 and pattern_2), yet to be configured.

Tap the **Edit** button under the name of a layer pattern to bring up the **Pattern editing menu**.

2. Add Pattern

Tap the **Add Pattern** button to add a layer pattern to the list.

3. Duplicate Pattern

If applicable, tap the **Duplicate** icon  to open the duplication menu.

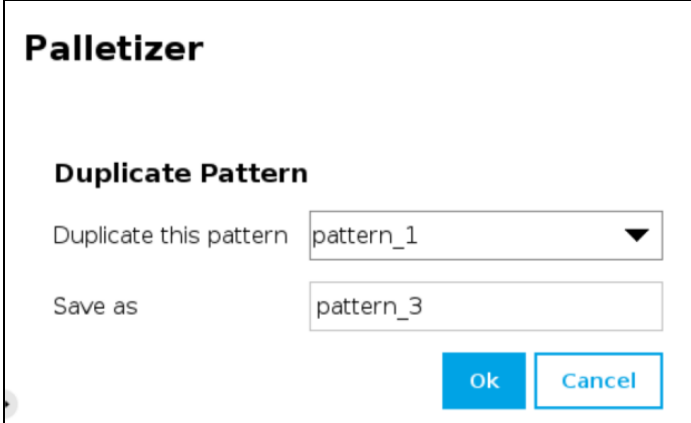

Fig. 5-22: Duplicate Pattern Menu

Duplicate a pattern and tap the **OK** button, or tap **Cancel** to go back to the Pattern menu.

4. Number of layers

Fill in this field with an integer to set the number of layers that will make up the pallet.

5. Current layer sequence

This preview indicates the layer sequence of the pallet pattern:

- A single layer pattern will display the actual name of the pattern.
- A multi-layer pattern will display "Mixed."

6. Edit Layer Sequence

Tap the **Edit Layer Sequence** button to bring up the Layer Sequence menu.



NOTICE

Patterns are specific to recipes, meaning that two distinct recipes can each be composed of patterns that are named identically.



Pattern Editing Menu

This interface includes a representation of a pallet.

The user can use the controls on the screen to fill the virtual pallet layer in the most efficient manner possible.

	NOTICE
	<p>What can be called the origin (0,0) in the pallet diagram is actually the top left corner of the pallet.</p> <p>And so, since the user can modify the coordinates of the active box, going left to right increases the X value, and going top to bottom increases the Y value.</p>

	NOTICE
	<ul style="list-style-type: none"> • A light blue box is a box that has been placed. It can be selected by tapping on it. • The dark blue box is the active box. It can be moved around using the arrows on the screen. • A red box is an "overlapping box." • Multi-pick feature: Boxes that are part of the active box type are shown in light blue (including the active box, in dark blue); boxes that are not part of the active box type are shown in grey.

Palletizer

1 **Pattern** pattern_1

2 < >

3 box_type_1 ▼

4 +
Add box

5 -
Remove box

6 ↑
← 90° →
↓

7 **Select all** 8 **Generate**

Move Strategy

9 Snapping

10 Movement step mm

SIDE

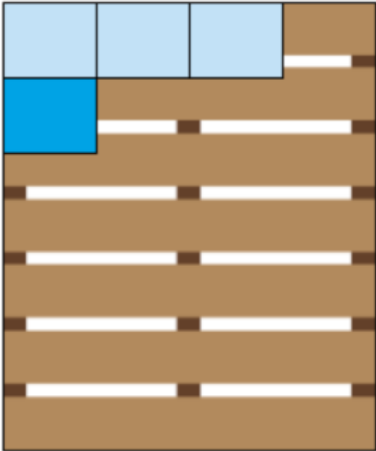

FRONT

11 X mm

Y mm

Fig. 5-23: Pattern Menu

1. Pattern name



This section displays the name of the layer pattern being edited.

2. Pattern toggle

Tap the left or right arrow to change the layer pattern being edited.

3. Box type dropdown menu (multi-pick feature)

If the **multi-pick feature** has been enabled in the **Settings** menu, and if more than one box type has been created in the **Box Type** menu, the Pattern editing menu will allow the user to select the box type to palletize, and to toggle between box types while building the layer pattern.

4. Add box

Tap the plus (+) button to add a box.

The first box will automatically be placed at the origin (0,0) of the layer (i.e., top left corner on the pallet).

The newly added box will feature a dark blue color, meaning it is the active box.



NOTICE

The user can select any box placed on the virtual pallet by tapping on it.
The selected box thus becomes the active box.

Any box added afterwards will feature a red color, meaning it overlaps a box.

Using the arrows on the screen, the user can move it around so that it does not overlap other boxes, and ultimately place it where it belongs on the pallet.



NOTICE

If the Set label orientation option has been selected in the Box menu, the boxes placed on the virtual pallet will each display an arrow pointing at the side of the box on which the label is affixed.



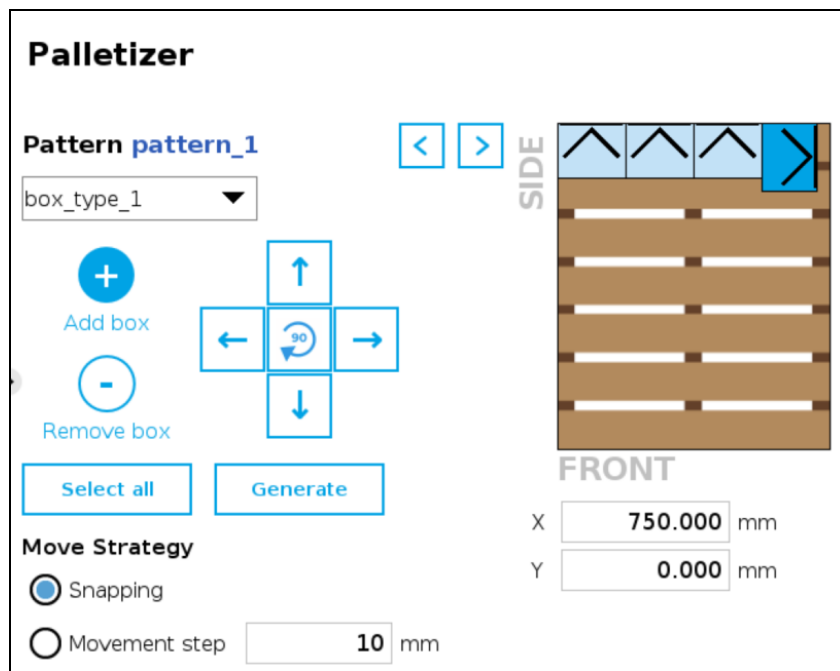



Fig. 5-24: Pattern Menu With Boxes Showing Label Orientation

5. Remove box

Tap the minus (-) button to remove the active box.

6. On-Screen movement pad

Tap the directional button that corresponds to the direction in which the box needs to move (up, down, left, right).

Use the middle button  to turn the active box 90 degrees clockwise.

7. Select all

Tap the **Select all** button to highlight all the boxes placed on the virtual pallet.

The user can then move the box group altogether using the on-screen movement pad or clear the layer by tapping the minus (-) button.

8. Generate

Tap the **Generate** button to let the system fill the entire pallet layer.



NOTICE

Multi-Pick Feature

If the **multi-pick feature** has been enabled in the **Settings** menu, tapping the **Generate** button will fill the pallet using the box type selected in the dropdown menu at the top of the interface.

9. Move Strategy - Snapping

The snapping movement mode consists in using the directional buttons to move the active box in a manner that will make it settle against the closest side of an adjacent box or against the corresponding side of the virtual pallet.



10. Move Strategy - Movement Step

The movement step mode consists in using the directional buttons to move the active box by increments of the value set in the field.

11. Box coordinates

The numbers in the fields correspond to the coordinates of the top-left corner of the active box.

The user can enter numbers to position the active box on the pallet, and ultimately place it where it belongs.

Layer Sequence Menu

The Layer Sequence menu is best described as being the interface used to set the order of layer patterns that will be stacked one on top of the other.

On the left-hand side of the screen, the lowest number is the closest to the pallet while the highest number is the farthest from the pallet.



NOTICE

In the example below, there are five (5) layers and two (2) patterns, but bear in mind that there can be a greater number of both depending on the palletizing application at hand.

The user can toggle between the different layer patterns created using the corresponding radio buttons.

Palletizer

Layer Sequence

Select the pattern used for each layer:

5	<input checked="" type="radio"/> pattern_1	<input type="radio"/> pattern_2
4	<input checked="" type="radio"/> pattern_1	<input type="radio"/> pattern_2
3	<input checked="" type="radio"/> pattern_1	<input type="radio"/> pattern_2
2	<input checked="" type="radio"/> pattern_1	<input type="radio"/> pattern_2
1	<input checked="" type="radio"/> pattern_1	<input type="radio"/> pattern_2



Fig. 5-25: Layer Sequence Menu



5.3.2. Use of force sensing for heavy payloads

To enhance the efficiency of palletizing operations while minimizing P-stops during box placement, this feature utilizes force sensing for a soft box placement. By default, this functionality is deactivated to maintain optimal palletizing speed. This feature should be activated only in scenarios where issues are encountered with payload transitions, as it may reduce the palletizing throughput.

When activated, this advanced feature enables the robot to execute a precise placement strategy. Initially, the robot will move horizontally towards the designated box position. This horizontal approach continues until the specified location is reached or until the robot detects contact with adjacent boxes. Subsequently, the robot lowers the box vertically until it either reaches the target position or establishes contact with the pallet.

This approach is designed to address and compensate for inaccuracies in both the grip of the box and its placement, ensuring a more reliable and efficient palletizing process.

Palletizer

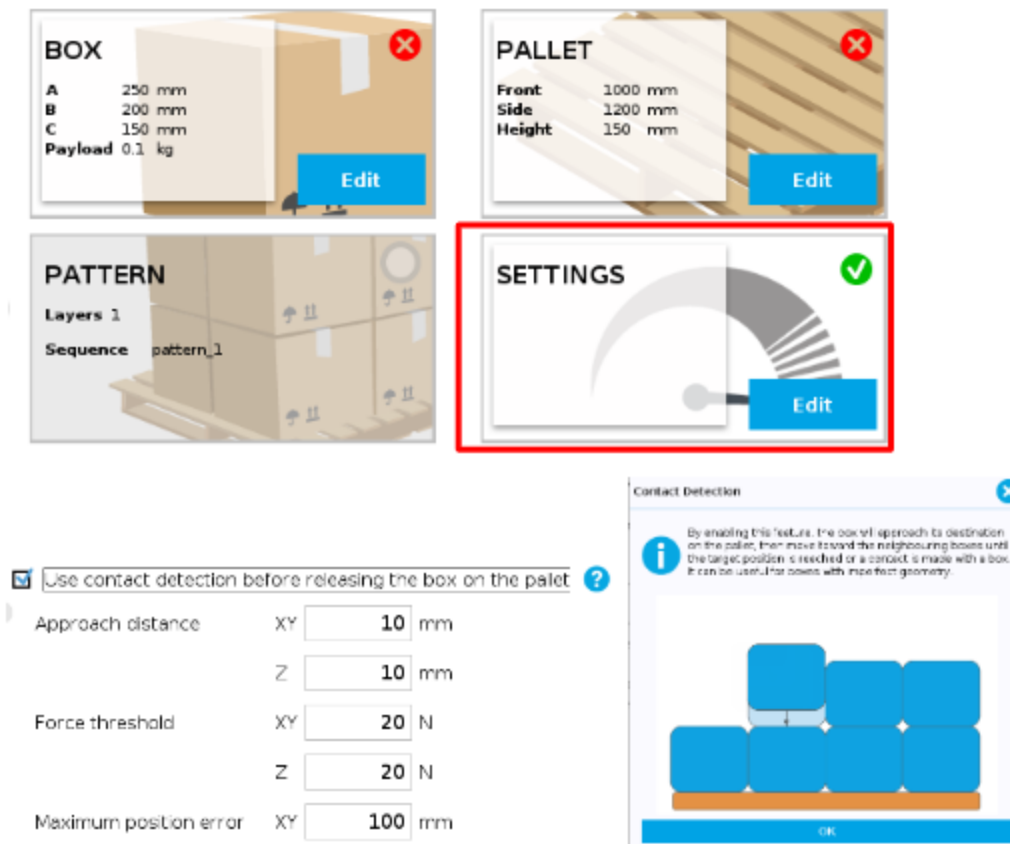

Fig. 5-26: Force sensing parameters

Parameters:

- Approach distance
 - These parameters define the distances from the target box position at which force sensing activation should start. Setting a greater approach distance enhances robustness at the expense of process speed. The XY parameter applies independently to each horizontal direction, whereas the Z parameter applies to the vertical direction.
- Force threshold
 - These thresholds determine the point at which the system recognizes a contact has been detected. Adjusting these thresholds allows for fine-tuning of the sensitivity to ensure optimal operations.



- Maximum position error
 - Specifies the maximum allowable deviation between the box's final position and its target. Should the discrepancy exceed this value, the system will generate an error message to alert the operator of the positioning issue.

5.4. Program Tree

5.4.1. Standard Palletizer Node

Robotiq's Palletizer node provides a quick, versatile, adaptable and efficient way to program palletizing and depalletizing movements and actions.

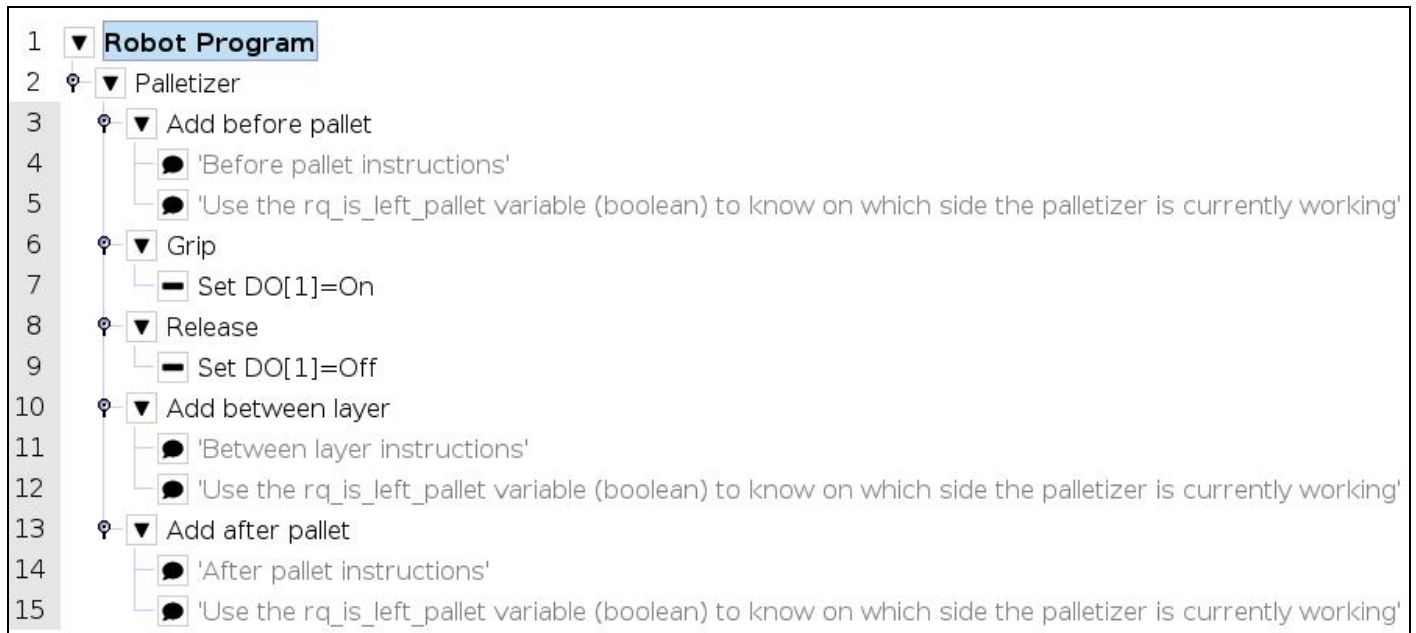

Fig. 5-27: Standard Palletizer Node in a Program Tree

In its most basic form, the Palletizer node allows the user to insert “before pallet” instructions, grip and release actions, “between layer” instructions, and “after pallet” instructions.

The actual instructions that make the robot arm and end effector go to and fro are managed by the URCap based on the settings of the single or multiple recipes chosen by the user. Please refer to the **Command Window** section for more information on the settings of the Palletizer node.

5.4.2. Palletizer Node With Multi-Pick Feature

The multi-pick feature is designed to allow for the processing of box groups and different box types, for instance, a double box type that corresponds to a single box doubled in size and payload.

The difference between the picking of a single box and the picking of multiple boxes lies in the detection of different box types via the box sensors. Please refer to the **Box Sensor (Multiple Box Types - Multi-Pick Feature)** section to install and connect multiple box sensors in order to properly use the multi-pick feature.

Grouped boxes should travel and end at the pick position, where the box sensors should be positioned (e.g., at the end of a conveyor).

Whereas the single box type will be detected by the single box sensor only, the double box type must be detected by two separate box sensors simultaneously.



The simultaneous signaling of each individual sensor will then combine into one signal that will be interpreted by the robot as an instruction to pick the grouped boxes (i.e., the double box type).

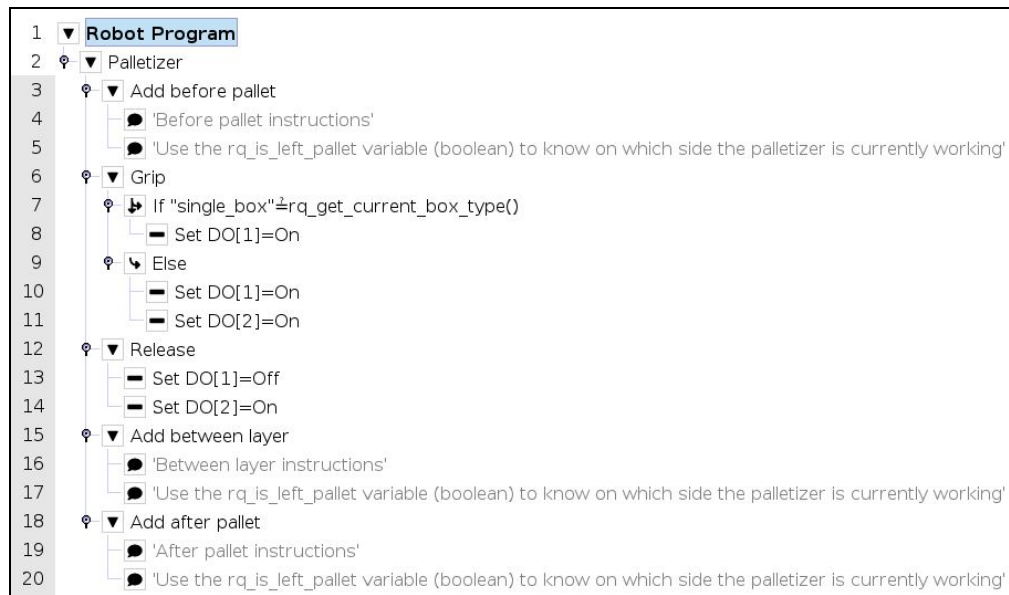

Fig. 5-28: Palletizer Node With Multi-Pick Feature

Thread Node

The following is an example of how to integrate the multi-pick feature in the robot program using script functions.



NOTICE

Tip: This approach can be used to accommodate special situations such as the need to add a wait time between the sensor signal and the ready-to-palletize signal to ensure that the boxes are at the exact pick position.

1. In the program tree, tap **Robot Program** at the very top.
2. Go to **Program > Advanced** and select **Thread**.
3. Tick the **Loops Forever** box at the bottom of the Thread screen (if not already ticked).



NOTICE

Thread nodes display at the end of the program tree; they work in parallel of the main program.



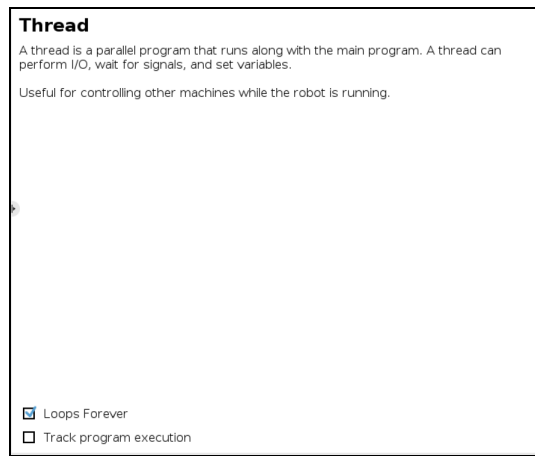

Fig. 5-29: Thread node

4. Insert a child **Set** node in the Thread parent node (**Program > Basic**).
5. Select the **Set** node, then tick the fourth radio button from the top
6. In the dropdown menu, select the **digital output** that has been connected to a **digital input** (please refer to the **Box Sensor (Multiple Box Types - Multi-Pick Feature)** section if this step has not been completed yet).

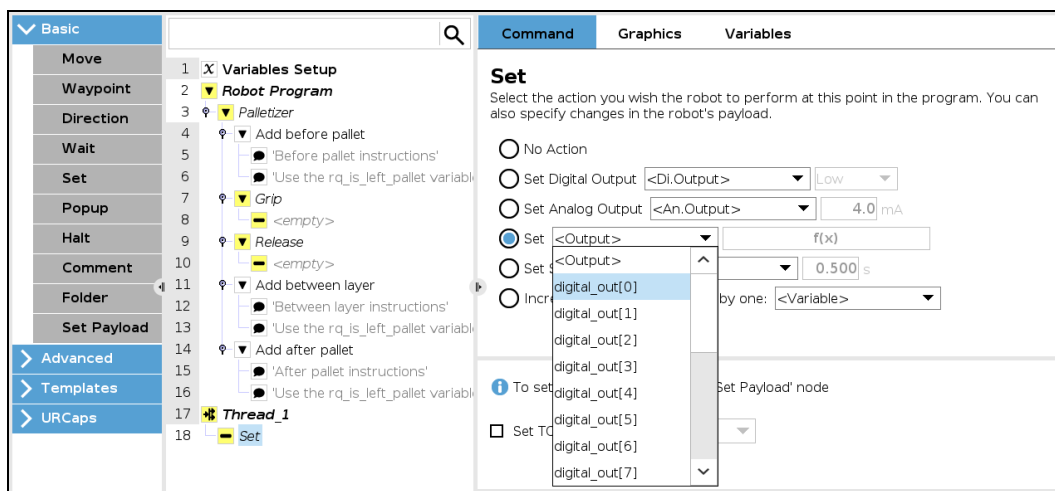

Fig. 5-30: Set Node in the Thread Node

7. Tap the **f(x)** button adjacent to the dropdown menu.
8. In the panel that just opened, expand the **Input** dropdown menu.
9. Select the digital input that corresponds to box sensor #1 (digital_in[0], in this example). Go through the **Box Sensor (Multiple Box Types - Multi-Pick Feature)** section to determine the digital input to select at this point.
10. Without inserting any space character, enter the word **and** or tap the **and** button on the panel.
11. Expand the **Input** dropdown menu.
12. Select the digital input that corresponds to box sensor #2 (digital_in[1], in this example). Go through the **Box Sensor (Multiple Box Types - Multi-Pick Feature)** section to determine the digital input to select at this point.



The result in the program tree should resemble this:



13. Go to **Program > Advanced** and insert a **Script** node.
14. In the **Script** node, tap the **f(x)** box.
15. In the dialog box, enter **sync()** and tap **Submit**.

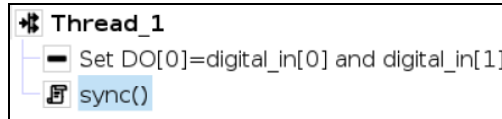

Fig. 5-31: Complete Thread Node in Program Tree

Gripper Activation

The following steps explain how to activate the right gripper for each box type.



NOTICE

Grippers are linked to digital outputs.

In the example below, there are two grippers: one linked to **digital_out[1]** and the other to **digital_out[2]**.

The link between box type and gripper-to-activate can vary depending on the configuration.

1. In the program tree, nest an **If** node within the **Grip** node (**Program > Advanced**).
2. Select the **If** node, tap the **f(x)** box in the Command window (leave the **Check expression continuously** box unticked).

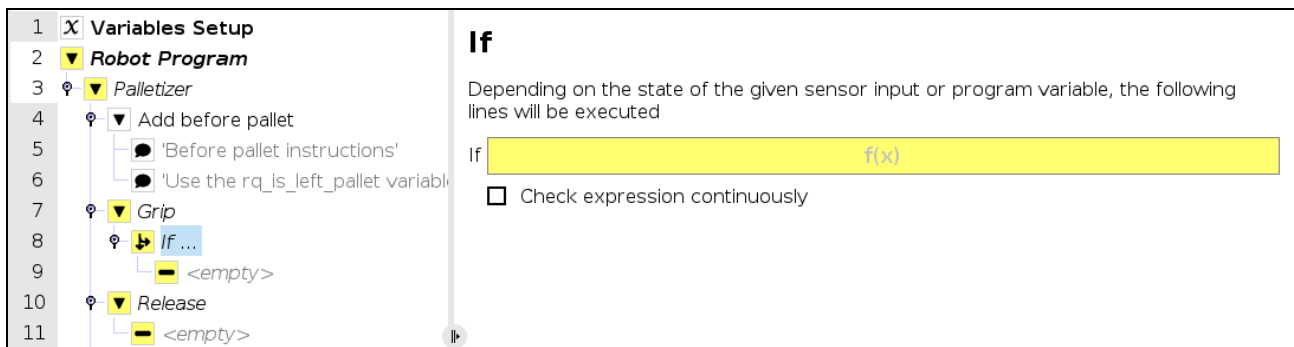

Fig. 5-32: If node in the Grip node

3. In the panel that opens:
 - a. Enter the name of the first box type between quotation marks.
 - b. Enter the **questioned equal to** symbol (\doteq) (use the keyboard in the panel to enter the appropriate symbol).
 - c. Open the **Function** dropdown menu



d. Select `rq_get_current_box_type()`.

e. Tap **Submit**.

The result in the Command window should resemble this:

If

Depending on the state of the given sensor input or program variable, the following lines will be executed

If

Check expression continuously



CAUTION

- The name of the first box type must **absolutely be between quotation marks**.
- The **questioned equal to** symbol (\doteq) **must** be entered using the keyboard in the panel.

4. In the program tree, select the **<empty>** node in the **If** node.
5. Go to **Program > Basic** and insert a **Set** node.
6. Select the **Set** node and tick the **Set Digital Output** radio button in the Command window.
7. Expand the dropdown menu.
8. Select the digital output to which the gripper in the **If** node is assigned.
9. Expand the adjacent dropdown menu.
10. Select **High**.



The result in the program tree and Command window should resemble this:

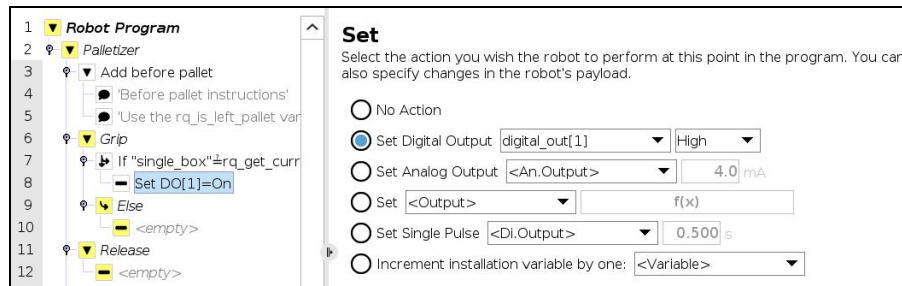

Fig. 5-33: Set Node in the If node

11. Select the parent **If** node and tap the **Add Else** button at the bottom of the screen.
12. In the program tree, tap the **<empty>** node in the **Else** node.
13. Go to **Program > Basic** and insert two **Set** nodes.
14. In the first **Set** node, tick the **Set Digital Output** radio button.
15. Expand the dropdown menu.
16. Select a digital output to which one of the grippers is assigned.
17. Expand the adjacent dropdown menu.
18. Select **High**.
19. Repeat steps 15 to 18 with the other **Set** node, but select the digital output to which the other gripper is assigned.

In doing so, both grippers will activate when the robot will be instructed to pick up grouped boxes.

The result in the program tree should resemble this:

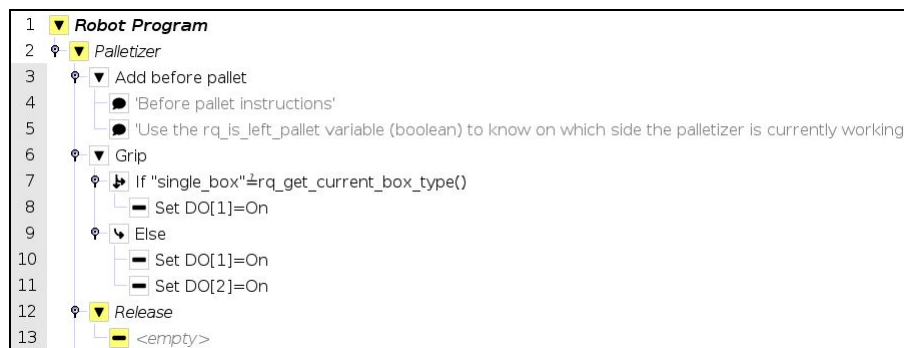

Fig. 5-34: Set Nodes in the Else node

20. In the program tree, select the **<empty>** node in the **Release** node.
21. Go to **Program > Basic** and insert two **Set** nodes.
22. In the first **Set** node, tick the **Set Digital Output** radio button
23. Expand the dropdown menu.
24. Select a digital output to which one of the grippers is assigned.



25. Expand the adjacent dropdown menu.
26. Select **Low**.
27. Repeat steps 23 to 26 with the other **Set** node, but select the digital output to which the other gripper is assigned.

In doing so, the system will release the vacuum action in both grippers, even if only one gripper was activated.

The result in the program tree should resemble this:

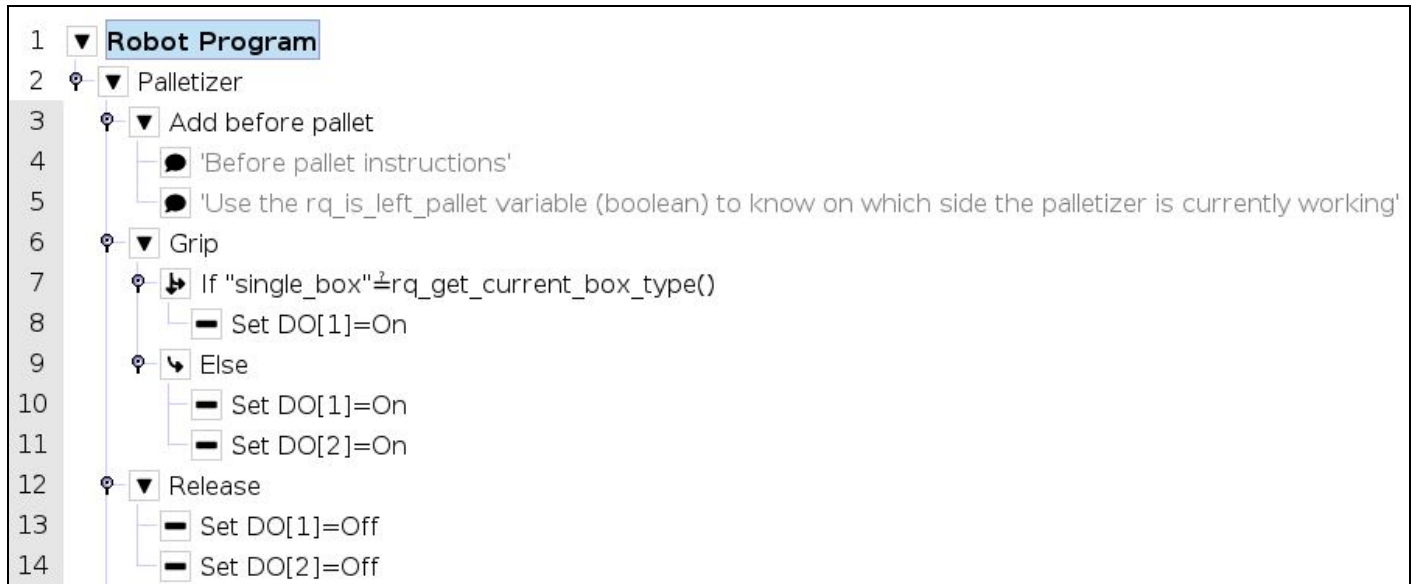

Fig. 5-35: Set Nodes in the Release node



5.4.3. Program Start - Pallet Viewer

If the option to **Validate pallet state at program startup** has been selected in the **Settings Menu** section of the Palletizer node, a Pallet viewer pop-up will display upon the start of the robot program for the user to confirm the state of the pallet.

If the multi-recipe feature has been enabled in the Settings menu of the Palletizer node, the Pallet viewer will automatically use and display the default recipes selected in the **Home View** section of the multi-recipe Palletizer node.

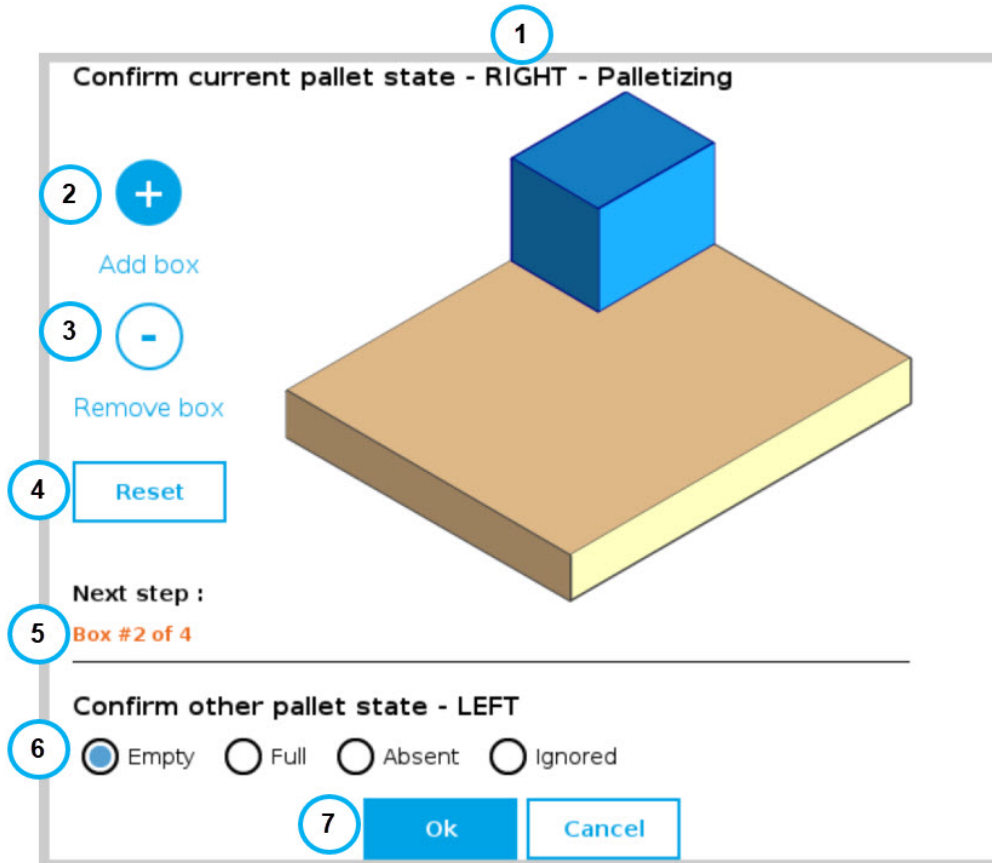

1. This callout shows the pallet on which the robot is currently working.
2. The **Add box** button is represented by a plus (+) symbol; tap the button to add a box to the pallet.



NOTICE

Should the Pallet viewer not display the current state of the pallet, the user can tap this button to add boxes so that it represents the exact state of the pallet prior to the start of the program.

3. The **Remove box** button is represented by a minus (-) symbol; tap the button to remove a box from the pallet.



NOTICE

Should the Pallet viewer not display the current state of the pallet, the user can tap this button to remove boxes so that it represents the exact state of the pallet prior to the start of the program.

4. The **Reset** button can be tapped to clear the pallet of any and all boxes; the Pallet viewer will then reflect the empty state of the physical pallet, provided that the physical pallet is actually empty.
5. This indicates the step that will occur next in the palletizing workflow.
6. The **Confirm other pallet state** section prompts the user to select the state of the other pallet (LEFT if the current pallet is the RIGHT one, or RIGHT if the current pallet is the LEFT one).



- **Empty**
 - In palletizing mode, the **Empty** state instructs the robot to process the pallet as if it were ready to be palletized from the very beginning.
 - In depalletizing mode, the **Empty** state indicates that the pallet should be replaced by a full pallet.
 - **Full**
 - In palletizing mode, the **Full** state indicates that the pallet should be replaced by an empty pallet.
 - In depalletizing mode, the **Full** state instructs the robot to process the pallet as if it were ready to be depalletized from the top down.
 - **Absent**
 - The **Absent** state is selected if no pallet is being detected by the pallet sensors on the corresponding side of the Palletizer at the start of the robot program, or if the pallet had been removed prior to the last time the robot program was stopped.
 - This radio button can be selected even though the pallet sensors have effectively detected the presence of a pallet. And so, even if deemed absent, the pallet will be processed by the Palletizer if it has been detected by the pallet sensors.
 - It is the responsibility of the user to select the current, actual state of the pallet at the start of the program.
 - **Ignored**
 - The **Ignored** state can be selected to instruct the robot not to process the pallet.
 - Even if the user chose to palletize both the left and right pallets in the **Pallet Menu** section, ticking this radio button will prevent the Palletizer from processing the corresponding pallet.
7. The OK button will start the robot program based on the pallet states validated by the user. The Cancel button will close the Pallet viewer pop-up, and the robot program will not start.



5.5. Palletizing Script Functions

Palletizing functions are made available in the **Script** dropdown menu.

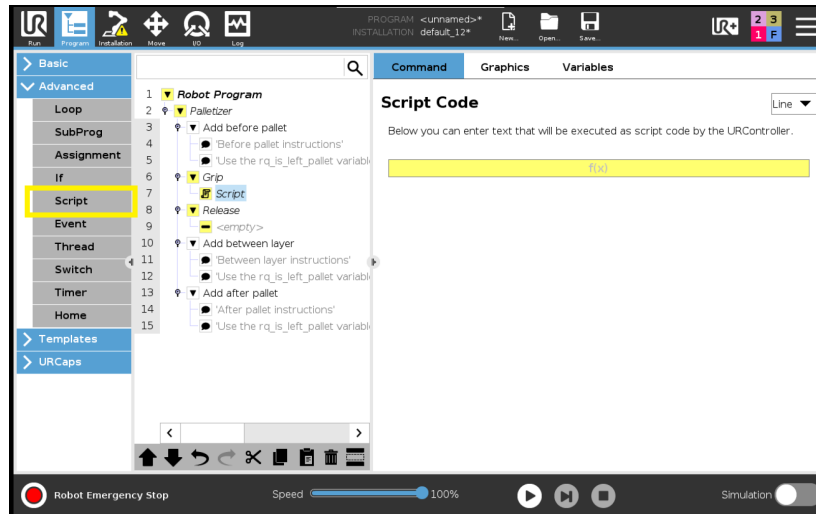

Fig. 5-36: Script node

Tap the Script Code textbox (**f(x)**), then on the **Function** dropdown menu.

Select the script function from the list.

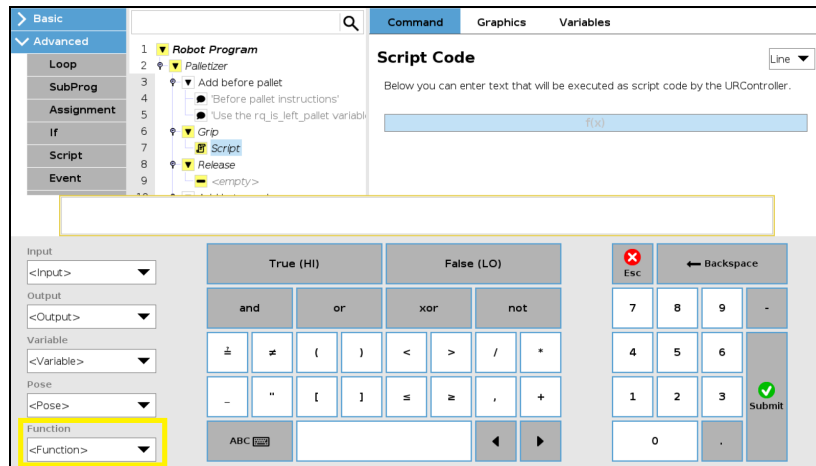

Fig. 5-37: Function dropdown menu in Script node

5.5.1. Number of Processed Boxes

Description

This function returns the number of processed boxes. It must be used inside the palletizer node in order to work properly.

Declaration

```
rq_get_nb_processed_boxes()
```

Returned value

This function returns an integer which expresses the number of processed boxes.



5.5.2. Set Pallet Completed

Description

This function allows to partially fill the pallets. The palletizer will process the current box and go directly to the **Add after pallet** folder. The **Add between layer** folder will not be executed.

Use this function inside a **Grip** or **Release** folder.

Declaration

```
rq_set_pallet_completed()
```

Returned value

There is no return value with this function.

5.5.3. Get Pallet State

Description

This function returns the state of a pallet. It can be used anywhere in the program.

Declaration

```
rq_get_pallet_state(is_pallet_left)
```

Parameters

- Enter **True** to get the state of the **left** pallet.
- Enter **False** to get the state of the **right** pallet.

Returned value

This function returns an integer from 0 to 3 :

- 0 = Waiting, Idle: Solution is waiting for a new pallet or a user confirmation that the pallet is ready.
- 1 = Ready: Pallet is ready to begin the palletizing or depalletizing process.
- 2 = In progress: Palletizing/depalletizing is in progress on the pallet.
- 3 = Completed: Pallet is full (palletizing) or empty (depalletizing).



5.5.4. Set Palletizer State

Description

This function configures the state of a Palletizer node. It must be used outside the palletizer node in order to work properly.

Declaration

```
rq_set_palletizer_state(palletizer_index, processed_boxes, next_step, other_pallet_state="ABSENT", current_pallet="CURRENT", left_recipe="", right_recipe="")
```

Parameters

- **palletizer_index**: Palletizer nodes for which the state will be numerically ordered, beginning from 0 (the first node number will be 0, the second node number will be 1 and so on).
- **processed_boxes** : Number of boxes palletized or depalletized on the current pallet.
- **next_step**: Next step on the current pallet.
 - "BOX": The robot will place a box on next step.
 - "BEFORE_PALLET": The robot will execute the **Add before pallet** on next step.
 - "BETWEEN_LAYERS": The robot will execute the **Add between layer** on next step.
 - "AFTER_PALLET": The robot will execute the **Add after pallet** on next step.
 - "NEXT_PALLET": On next step, the robot will start processing the other pallet.
- **other_pallet_state**: State of the other pallet (not currently processed).
 - "EMPTY": There is no box on the pallet.
 - "FULL": The pallet is full of boxes.
 - "ABSENT": The pallet is not in place.
 - "IGNORED": The Palletizer node will disregard the other pallet, even if it is detected.
- **current pallet**: The pallet on which the robot is currently working on.
 - "LEFT": The current pallet is the left one.
 - "RIGHT": The current pallet is the right one.
 - "CURRENT": The current pallet is the same as before calling this function.
- **left_recipe**: Corresponds to the recipe to process on the left side of the Palletizer. The user can leave this argument blank to continue processing the left pallet with the same recipe. The user can also enter the exact name of a specific recipe to replace the current recipe.
- **right_recipe**: Corresponds to the recipe to process on the right side of the Palletizer. The user can leave this argument blank to continue processing the right pallet with the same recipe. The user can also enter the exact name of a specific recipe to replace the current recipe.

Returned value

There is no return value with this function.



5.5.5. Get Current Box Type

Description

This function returns the box type being processed when multiple box types are enabled. It must be used inside the palletizer node in order to work properly.

Declaration

```
rq_get_current_box_type()
```

Returned value

This function returns a string which is the name of the box type currently being processed. The string is case-sensitive

5.5.6. Get Current Pallet Recipe

Description

This function returns the pallet recipe being processed when the multi-recipe feature is enabled. It has to be used inside the Palletizer node in order to work properly.

To use this script function in a condition (e.g., `if(rq_get_current_box_type()="recipe_1")`), the name of the recipe has to be entered exactly as it has been initially named in the list of recipes available.

Declaration

```
rq_get_current_pal_recipe()
```

Returned value

This function returns a string which is the name of the recipe being processed. The string is case-sensitive.

5.5.7. Use Payload with Box

Description

This function can be used in the Palletizer Grip or Release folder for the robot to act as if the actual payload and center of gravity values were the values set via the **Box Menu** or the Set Box Payload function. Generally used to manage high payloads.

Declaration

```
rq_use_payload_with_box(ratio)
```

Parameters

ratio: Percentage of the box payload. Must be between 0 and 1 (0 to 100%)

Returned value

There is no return value with this function.



5.5.8. Use Payload No Box

Description

This function can be used in the Palletizer Grip or Release folder for the robot to act as if the actual payload and center of gravity values were the same as if there was no box present. Generally used to manage high payloads.

Declaration

```
rq_use_payload_no_box()
```

Returned value

No value is returned

5.5.9. Set Box Payload

Description

This function can be used to set or change the payload values of the box. It is to be noted that this function does not change the active payload of the robot. It applies to all boxes of the current box type. Generally used to manage high payloads.

Declaration

```
rq_set_box_payload(box_payload)
```

Parameters

box_payload: The mass of the box in kg.

Returned value

There is no return value with this function.



6. Specifications



NOTICE

This manual uses the metric system. Unless specified, **all dimensions are in millimeters.**

6.1. Technical Dimensions

6.1.1. Base with Pedestal, Robotiq Control Box and Operator Station

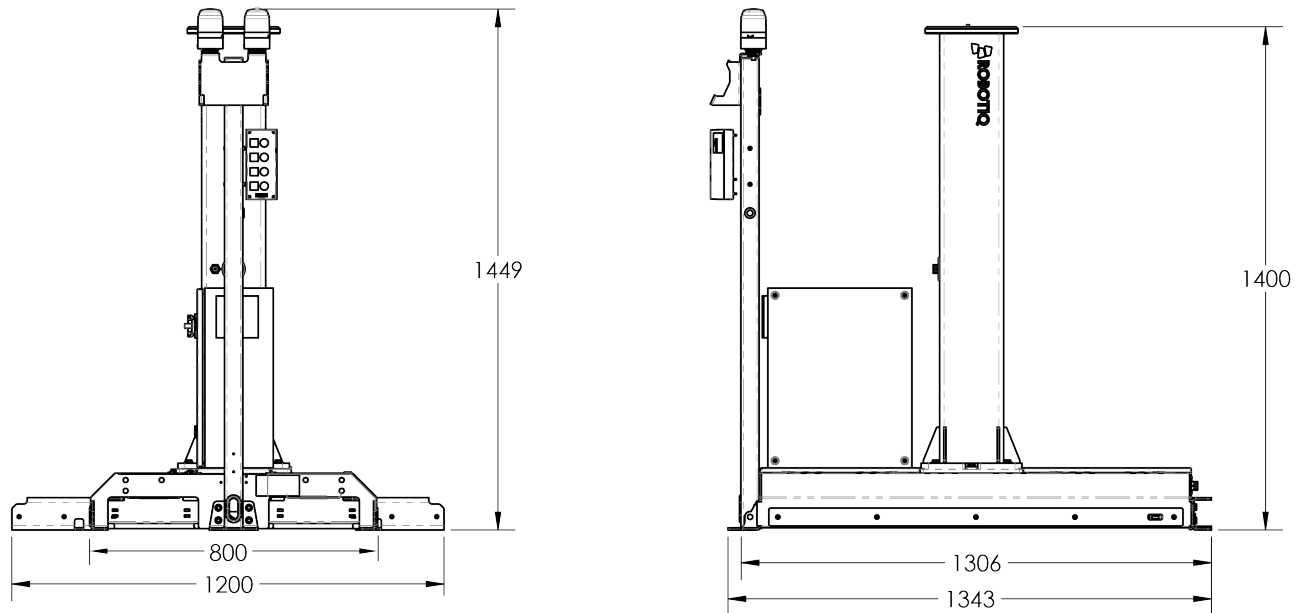

Fig. 6-1: Base with Pedestal, Robotiq Control Box and Operator Station - Technical Dimensions

6.1.2. PowerPick20 Vacuum Gripper (Optional)

For the technical dimensions of the PowerPick20 Vacuum Gripper, please refer to the Technical Dimensions section of the PowerPick20 user manual, available at support.robotiq.com.



6.2. Mechanical Specifications

6.2.1. Palletizing Solution (Without Robot and End-of-Arm Tooling)

Parameter	Specification	
	Metric	Imperial
Net product weight (without robot and gripper)	157 kg	345 lb
Base weight	82 kg	180 lb
Pedestal weight	54 kg	119 lb
Pedestal height	1400 mm	55.1 in
Payload (without gripper) ¹	Up to 20 kg	Up to 44 lb
Minimum box dimensions ²	See explanations below	
Minimum pallet width and depth	300 mm	12 in
Maximum pallet dimensions width and depth ³	See explanations below	
Minimum pallet height (empty)	90 mm	3.5 in
Maximum pallet height (filled)	2150 mm	84 in
Shipping crate dimensions	1496, 924, 905 mm (L, W, H)	59, 36.5, 35.6 in (L, W, H)
Gross shipping weight	230 kg	506 lb
Maximum acceleration in operating conditions	2 g	
Maximum supply pressure ⁴	10 bar	145 psi
Maximum throughput	Up to 13 cycles/min ⁵	
Maximum number of box patterns	No constraint	
Energy source	Electricity	

Table 6-1: Mechanical Specifications of the Robotiq Palletizing Solution

¹Maximum box weight depends on the robot model and gripper used.

²Minimum box dimensions depend on pallet dimensions. Use the [Robotiq Configurator](#) to validate the combination

³Maximum pallet dimensions depend on your box dimensions and pallet configuration. Use the [Robotiq Configurator](#) to validate the combination

⁴Please refer to the pneumatic diagram.

⁵Maximum box throughput depends on box weight, box dimensions, box surface, pallet dimensions, and pallet layout.



6.2.2. PowerPick20 Vacuum Gripper (Optional)

For the mechanical specifications of the PowerPick20 Vacuum Gripper, please refer to the **Mechanical Specifications** section of the PowerPick20 user manual, available at support.robotiq.com.

6.3. Electrical Specifications

6.3.1. PowerPick20 Vacuum Gripper (Optional)

For the electrical specifications of the PowerPick20 Vacuum Gripper, please refer to the **Electrical Specifications** section of the PowerPick20 user manual, available at support.robotiq.com.

6.3.2. Universal Robots Controller

Refer to the **Installation** section for more details about connections to the UR control box.

6.3.3. Robotiq Control Box

Parameter	Specification
Operating supply voltage	100 VAC to 240 VAC 60/50 Hz
Current consumption (excluding robot)	2.2 A (100 VAC) 1.9 A (120 VAC) 1.1 A (230 VAC) 1.1 A (240 VAC)
Current consumption (with UR20 robot and 20 kg payload) ¹	8.3 A (100 VAC) 6.9 A (120 VAC) 3.6 A (230 VAC) 3.4 A (240 VAC)

Table 6-2: Electrical specifications of the Robotiq control box.

¹Measured values. May depend on modifications made by Universal Robots.



WARNING

The Robotiq control box is CE marked and cCSAus certified. Any modification will void the certification.

The following diagram illustrates the basic connections of the Robotiq control box. For more information, download the electrical package on the Robotiq support website. Do not modify the wiring of the unless it can be recertified in accordance with local rules, regulations and standards.



NOTICE

The direct input (DI) terminals to which the Pause and Restart wires need to be connected are at the user's choice.



System Overview

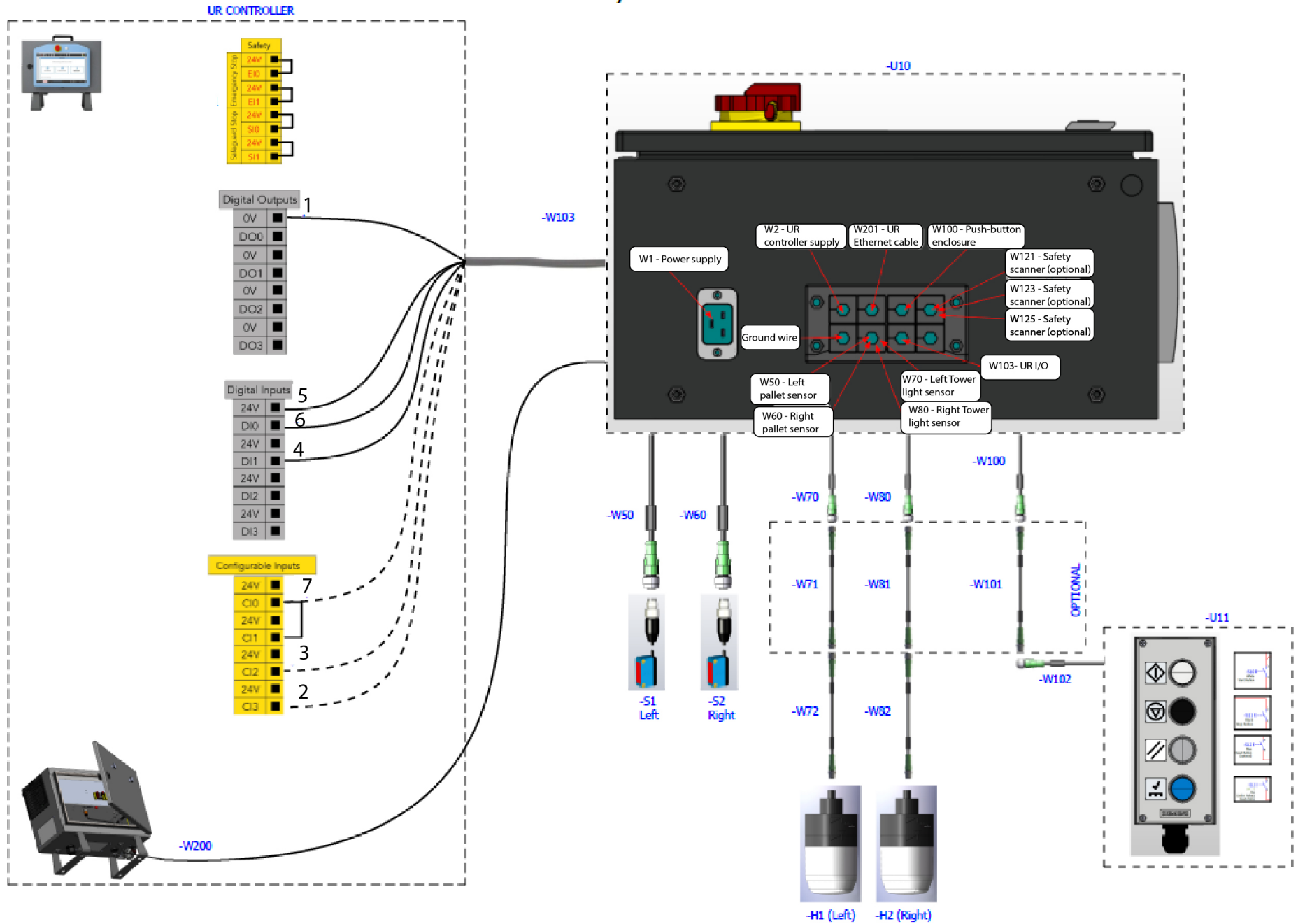

7. Periodic Inspection and Maintenance



CAUTION

Maintenance operations are for the average normal use of the Robotiq Palletizing Solution. Maintenance intervals should be adjusted according to the environmental conditions.

Following maintenance intervals will ensure:

- The correct functioning of the equipment
- The validity of the warranty
- The prescribed lifetime of the equipment.
- The safe operation of the equipment



WARNING

Take all safety measures during maintenance operations on the Robotiq Palletizing Solution. Please refer to the **Safety** section for additional information.



CAUTION

- Always turn off the Palletizing Solution and depressurize the air supply tube before performing any maintenance operation. For more details about the depressurization, please refer to the **Depressurizing the Supply Line** section.
- The Palletizing Solution is not waterproof or water resistant without additional protection. Clean the equipment with a dry towel.
- Maintenance operators must be grounded to prevent electrostatic discharge that could damage electronic equipment.

7.1. Power Off and Lock Off Procedure



WARNING

The power off and lock out procedure must be followed before performing any maintenance or inspection operation on the equipment.

Pneumatic power should be shut off and locked out upstream of the solution, or completely disconnected.



The system must be depressurized before performing maintenance operations on the solution. The way the system is depressurized will depend on the gripper used.

When using the PowerPick20 Vacuum Gripper, simply activate the vacuum or blow off output, and wait for the pressure to drop completely.



PowerPick20 also includes a shut off valve that can alternatively depressurize the system downstream and be locked in the exhaust position. In the latter case, the upstream section remains pressurized.



To turn off the electrical power downstream of the Robotiq control box, switch the main isolator off and lock it in the off position. It is also possible to unplug the main power cable from the power outlet.

	 CAUTION
	<p>Follow these 4 electrical engineering safety rules when working on electrical equipment:</p> <ul style="list-style-type: none">• Disconnect completely• Secure against reconnection• Make sure there is no voltage• Provide protection against adjacent live components

7.2. Inspection

	 WARNING
	<p>Failure to perform the following inspection at the specified interval can result in material damage, death or serious injury.</p> <p>Failure to repair defective items before putting the equipment back into operation may result in material damage, death or serious injury.</p> <p>Prior to performing the inspection of the equipment, the power off and lock out procedure must be followed. Please refer to the Power Off and Lock Off Procedure section for more information.</p>

The following inspection procedure should be performed at regular 350-hour intervals of equipment usage.

If issues are identified during the inspection procedure, the damaged or otherwise worn elements must be replaced or repaired before putting the equipment back into operation.

7.2.1. PE20 Palletizing Solution

The torque required for all fasteners mentioned in this section is specified in **Fastener Specifications** section.

Anchor Points

- Inspect the four (4) anchor points at each corner of the Solution.
- Make sure the fasteners are present and tightened to the appropriate torque.



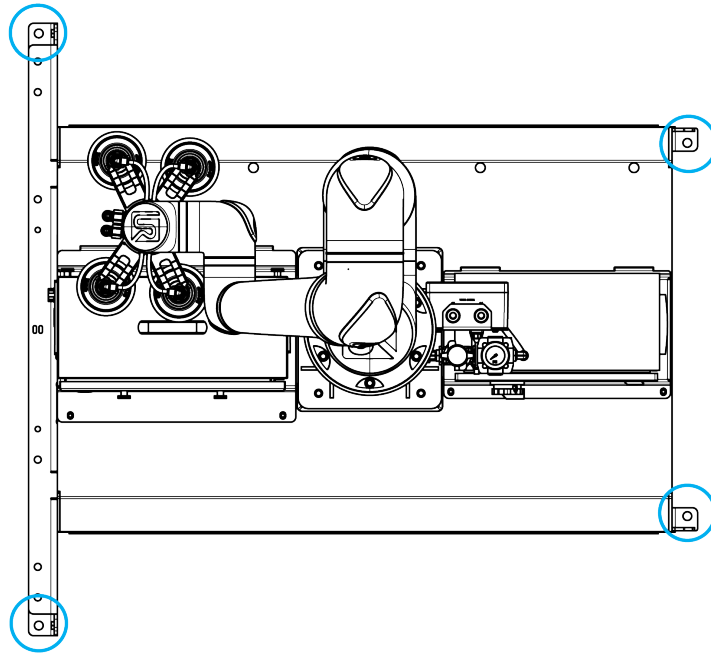

- Inspect the concrete around the four (4) anchor points at each corner of the Solution.
- Make sure the concrete is in good condition with no cracks, chips or other hazards.

Palletizer Structure

- Inspect the metallic structure of the base of the palletizer.
- Make sure the base does not display cracks, bends, surface damage or other signs of failure on sheet metal and welding spots or beads.
- Verify that the four (4) screws used to mount the removable stopper to the base are present and tightened to the appropriate torque.

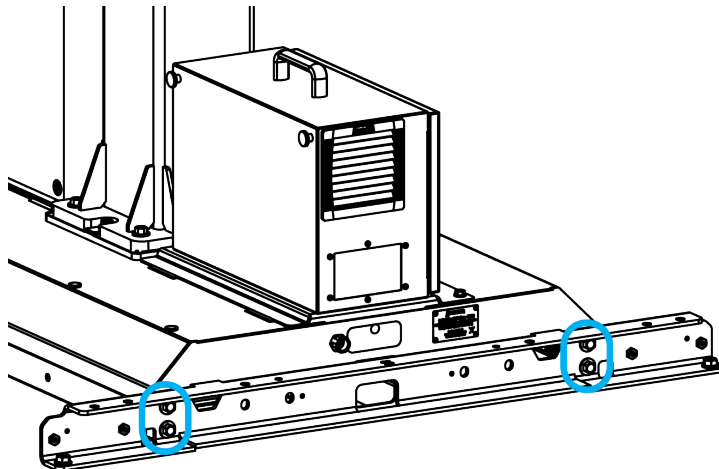

Electrical

- Periodically verify that the “Confirm pallet(s) ready” button still needs to be pressed for the robot to start palletizing on an empty pallet.



Pedestal

Inspect the pedestal.

- Verify that the four (4) screws holding the pedestal to the base of the Solution are present and tightened to the appropriate torque.

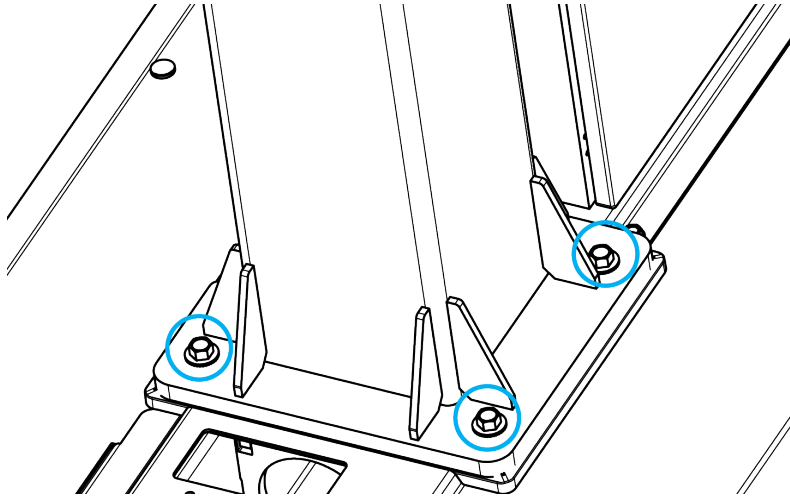

Robot

- Inspect the flanged joint between the robot's base and the pedestal.
- Verify that the six (6) bolts at the base of the robot are present and tightened to the appropriate torque.

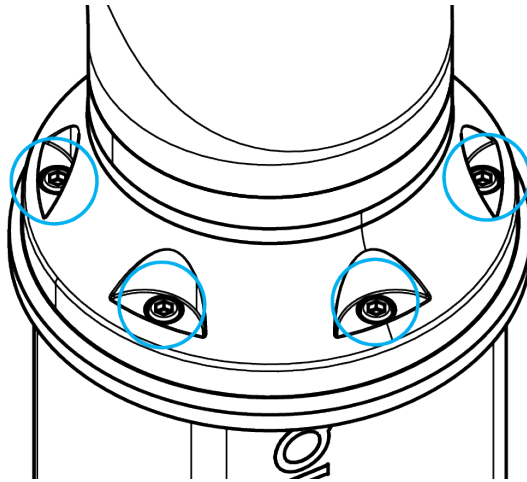

Cabling and Tubing

Inspect all cabling and tubing.

- Examine the pneumatic tubing for signs of wear, tear, cracking, crushing or bending.
- Verify that the pneumatic tubing is firmly attached to the cable clips and curler, and, in turn, to the robot arm.
- Examine the cable ties, cable clips and curler for signs of wear, tear or cracking.
- Examine the cables and wires for signs of wear, damage or pinching.
- Examine the sheath of cables and wires for signs of tear or cracking.



7.2.2. PowerPick20 Vacuum Gripper (Optional)

For more information about the inspection guidelines for the Vacuum Gripper, please refer to the **Maintenance** section of the PowerPick20 user manual available at support.robotiq.com.

7.3. Fastener Specifications

Inspect all screws and bolts periodically to make sure they are tightened to the appropriate torque, as represented in the table below.

Diameter / TPI	Location	Torque	
		[Nm]	[lb-ft]
M12	Removable stopper - Base	84 ¹	62 ¹
M12	Pedestal - Base	84 ¹	62 ¹
M10	Robot-pedestal link	Refer to UR20 User Manual ²	Refer to UR20 User Manual ²
M8	Operator station - Base	25	37
1/2"-13	Wedge anchors	70	52
M8	Control box and Vacuum Generation Unit holder plates	5	3.7

Table 7-1: Torque Values - Palletizing Solution

¹ Medium strength threadlocker must be applied.

² Use serrated Belleville washers.

7.3.1. PowerPick20 Vacuum Gripper (Optional)

For more information about the fastener specifications of the Vacuum Gripper, please refer to the **Maintenance** section of the PowerPick20 user manual available at support.robotiq.com.



CAUTION

Unless specified, any repairs performed on the Vacuum Gripper or Vacuum Generator should be done by Robotiq, otherwise the warranty will be void.



7.4. Cleaning

7.4.1. Palletizing Solution

The solution should be cleaned at regular intervals depending on the environment in which it is located.

Clean the mechanical components with a soft cloth, as required.

Use non-abrasive cleaning agents and media.

Periodically clean the Robotiq control box air filters and replace them when necessary.

Gently clean the photoelectric pallet sensor window using a soft cloth as needed.

7.4.2. PowerPick20 Vacuum Gripper (Optional)

For more information about the cleaning guidelines of the Vacuum Gripper, please refer to the **Maintenance** section of the PowerPick20 user manual available at support.robotiq.com.

7.5. Storage

Choose cool, dry and well-shaded environments.



8. Spare Parts, Kits and Accessories



NOTICE

The following list is deemed up to date based on the moment at which this document was built. It is subject to change. Please check online for updates.

Item	Description	Ordering Number
Tower Light for Palletizing Solution	1 x Tower Light for the Robotiq Palletizing Solution	TOWER-LIGHT
Box Sensor Kit - Palletizing Solution	<ul style="list-style-type: none"> 1 x Box Sensor 1 x Cable 1 x Mounting Bracket 	PAL-BOX-SENS-KIT
Replacement Pallet Sensor for PE20	<ul style="list-style-type: none"> 1 x photoelectric sensor 1 x mounting bracket 1 x screw kit 	PAL-SENS-PHOTOELEC
Cable Management Kit for UR20	<ul style="list-style-type: none"> 3 x cables clips + 0.5 m hook and loop (VELCRO®) 1 x cables clip + 1 m hook and loop (VELCRO®) 1 x tubing curler (for use on double pneumatic tubing only) 10 x 190 mm cable ties 	SOL-ROBOT-CBL-MNGT-UR20
Air Filter for PE Series Control Box	Replacement air filters for Robotiq control box (pack of 5)	PAL-CTRL-BOX-FILTER-PE
Overhang Kit for PE20	<ul style="list-style-type: none"> 4 x overhang spacers 4 x screw kits <p>Allows for overhangs of up to 35 mm (1-3/8 in) on the inner pallet sides, and between the pallet and removable stop. Can be used to add overhangs in the X and Y axes, or in both directions.</p>	PAL-OVERHANG-KIT-35MM



Item	Description	Ordering Number
Removable Stop Channel Kit for PE20	<ul style="list-style-type: none"> • 1 x stop channel • 2 x anchors • 4 x bolts for fastening to the base 	PAL-REMOVABLE-STOP-PE20
Standalone Safeguard Reset Button (blue)	Allows the use of the safeguard reset button, pre-wired to the PE20 push button enclosure.	PAL-SFGRD-RESET-PUSH-BUTTON

8.1. PowerPick20 (Optional Gripper) Spare Parts & Accessories

Item	Description	Ordering Number
PowerPick20 Vacuum Generation Unit	<ul style="list-style-type: none"> • 1 x PowerPick20 Vacuum Generation Unit • 1 x M12 12-pin I/O cable 	VAC-POWERPICK20-CTRL-UNIT
PowerPick20 Gripper Unit	<ul style="list-style-type: none"> • 1 x Manifold assembly • 1 x Small bracket assembly • 4 x Air nodes with 110 mm suction cups • 1 x Large bracket assembly • 4 x 8 mm air tubes (275 mm) • 1 x 12 mm double air tube (3.63 m) • 1 x Tools and hardware kit for installation on UR20 	VAC-POWERPICK20-GRP-UNIT
PowerPick20 Cable Kit	<ul style="list-style-type: none"> • 1 x PowerPick20 assembly tube • 4 x 8 mm air tubes (275 mm) • 10 x 190 mm cable ties 	SOL-PAL-POWERPICK20-CBL-KIT
Air Pressure Regulator + Filter Kit for PowerPick20	<ul style="list-style-type: none"> • 1 x Pressure regulator • 1 x Filter kit • 1 x Mounting bracket 	PAL-PNEU-FILTR-REG



Item	Description	Ordering Number
Kit of 4 Suction Cups - Piab 110 mm G3/8	<ul style="list-style-type: none"> • 4 x Piab 110 mm (1.5 bellows) • 4 x 3/8 BSPP threaded adapters 	VAC-CUP-PIAB-110MM-G38-KIT-4
Replacement Air Filter for PowerPick20	Replacement air filter used for the pneumatic accessories kit (PAL-PNEU_FILTR-REG) provided with the Palletizing Solution with the optional PowerPick20 Gripper	PAL-PNEUMATIC-FILTER
Kit of 4 Suction Cups - Piab 75 mm G3/8	<ul style="list-style-type: none"> • 4 x Piab 75 mm (1.5 bellows) • 4 x 3/8 BSPP threaded adapters 	VAC-CUP-PIAB-75MM-G38-KIT-4
PowerPick20 200 mm X-Axis Offset	<ul style="list-style-type: none"> • 1 x 200 mm hollow offset link • 4 x M8 socket head flange screws • 2 x 8 mm air tubes (275 mm) • 2 x 8 mm air tubes (475 mm) 	VAC-POWERPICK20-XOFFSET-KIT
PowerPick20 Z-Axis Offset	<ul style="list-style-type: none"> • 1 x 100 mm wrist extension • 4 x M8 socket head flange screws 	VAC-POWERPICK20-ZOFFSET-KIT



9. Troubleshooting

9.1. Palletizing Solution (excluding the PowerPick20 Vacuum Gripper)

Symptom / Issue	Cause	Solution
Robot comes to a protective stop after palletizing a few layers	<p>A collision occurred between the gripped box and a box on the pallet.</p> <p>A minor palletizing error carried over from previous layers.</p>	Increase box height value to compensate for box size discrepancies. A good practice to determine box height is to measure the height of a full pallet (boxes only), and divide it by the number of layers on the pallet.
Robot drops boxes from great heights	Minor palletizing error carried over from previous layers.	Decrease the box height value.
	Incorrect TCP.	Confirm TCP is located above the box, at the picking position.
	Pallet height value is too low.	Increase pallet height value.
Robot collides with palletized box	<p>A collision occurred between the gripped box and a box on the pallet.</p> <p>A minor palletizing error carried over from previous layers.</p>	Increase the box height value to compensate for box size discrepancies. A good practice to determine box height is to measure the height of a full pallet (boxes only), and divide it by the number of layers on the pallet.
	One or several faces of the box are rounded.	Increase box width and/or box length value.
	Pallet viewer does display actual pallet state.	Inspect Pallet viewer at program start and confirm the virtual layout matches the actual layout.
	Pallet height value is too high.	Decrease the pallet height value.



Protective stop triggered by robot placing a box on first layer	Box height value is too high.	Verify the box height value.
	Pallet height value is too high.	Verify the pallet height value.
	Incorrect TCP.	Confirm that the TCP has been set correctly.
Inconsistent box positioning	Unstable picking position.	On the conveyor, make sure the stop consistently positions the boxes correctly.
	Incorrect picking position.	Make sure that the vacuum gripper is squared and centered with the box at the picking position.
"Collision detected" error message during trajectory	Pallet viewer layout does not correspond to actual physical layout. The robot detected a collision with an object that is not physically present.	<ul style="list-style-type: none"> Restart the program and select the corresponding box step. Verify the TCP position and orientation values.
"Discontinuous path / joint solution impossible detected, please change your starting point" error message	Singularity occurred on planned trajectory.	<ul style="list-style-type: none"> Go to the PolyScope Move tab, and verify if the joints are at the center of their range (0°) when the robot is at the picking position. The algorithm will adjust wrist 3 automatically at program start. If the box position is too close to the robot base, discontinuous path issues can occur. Verify that the picking zone is respected. If this situation only occurs with pallets on one side of the Solution, try centering the layer pattern on the pallet. Verify TCP position and orientation values. The robot may have reached a singularity or be close to reaching a singularity. Move the robot to the Home position and restart the program. Should none of the above steps solve the issue, please contact support@robotiq.com.



<p>The box layer shows a rotational offset relative to the surface of the pallet. Collisions can occur with the pallet sensor on one side, but not on the other.</p>	<p>not centered on the base.</p>	<p>Execute the centering procedure found in the Installation section.</p>
<p>A collision occurred</p>	<p>Incorrect TCP.</p>	<p>Confirm that the TCP has been configured correctly</p>
	<p>TCP does not account for the bracket used.</p>	<p>Configure the TCP correctly.</p>
	<p>Gripper size extends beyond box.</p>	<p>The size of the surface covered by the gripper or suction device should always be equal or smaller than the size of the face of the box that is being gripped. Please refer to the Other Grippers section for more details.</p>
<p>Robot waits indefinitely over picking position</p>	<p>Box presence sensor is misused or not connected.</p>	<ul style="list-style-type: none"> • Verify that the correct box presence input has been selected. • Verify that the sensor used is active high if a sensor other than the sensor provided is being used.
<p>Robot comes to a protective stop during palletizing</p>	<p>Joint limit exceeded.</p>	<ul style="list-style-type: none"> • Verify that the joint speed and position limits have been configured correctly. Please refer to the Robot Configurations section for more information. • Decrease the value of the acceleration parameter in the Palletizer node.
<p>Error message: "RTDE interface cannot initialize. Make sure that Ethernet/IP adapter and Profinet are disabled, and that no other URCap uses the RTDE interface."</p>	<p>Registers cannot be used in conjunction with Ethernet/IP or PROFINET when the following function checkbox is ticked: Installation > URCaps > Copilot > Configuration > General: "Use Copilot to manage a soft speed transition when resuming from a Safeguard stop"</p>	<ul style="list-style-type: none"> • Update to the latest version of the Copilot software. • Untick the "Use Copilot to manage a soft speed transition when resuming from a Safeguard stop" checkbox.



9.2. PowerPick20 Vacuum Gripper (Optional)

If the desired vacuum level cannot be reached or if a loss of vacuum occurs:

- Verify the feed pressure level; adjust accordingly
- Inspect the condition of the suction cups; replace if necessary
- Make sure that the air path, including the manifold, is clean and unobstructed
- Inspect the air filter; clean if necessary





CAUTION

For more information on troubleshooting the PowerPick20 Vacuum Gripper, please refer to the **Troubleshooting** section of the PowerPick20 user manual, available at support.robotiq.com. If necessary, send an inquiry to the support team at : support@robotiq.com.



10. Warranty

Robotiq covers the Robotiq Palletizing Solution and all its components against defects in material and workmanship for a period of one year from the date of reception when utilized as intended. Robotiq also warrants that this equipment will meet applicable specifications under normal use.

	 WARNING
	<p>The warranty applies under the following conditions:</p> <ul style="list-style-type: none">• Usage is made in accordance with the operating and storage conditions specified in the Environmental and Operating Conditions section.• The product and all its components have been properly installed as specified in the Installation section and following subsections.• Maintenance is performed in accordance with the conditions specified in the Maintenance section.• Usage complies with the recommended payload, force, acceleration and speed values specified in the Mechanical Specifications section. <p>The warranty will come to an end when one of the following conditions is reached, whichever comes first:</p> <ul style="list-style-type: none">• 1 year• 2 000 000 cycles (boxes or objects manipulated, PowerPick20 only)

During the warranty period, Robotiq will repair or replace any defective component of the Palletizing Solution, as well as verify and adjust the component free of charge if the equipment should need to be repaired or if the original adjustment is erroneous. If the component is sent back for verification during the warranty period and found to meet all published specifications and to work as intended, Robotiq will charge standard verification fees.

The component is considered defective when at least one of the following conditions occurs:

- The component feedback necessary for the proper functioning of the robot program is not accessible.
- The component cannot be controlled from the robot teach pendant.





CAUTION



Should one of the following events occur, the warranty will become null and void.

- The unit has been tampered with, repaired or worked on by unauthorized individuals.
- Screws, other than as explained in this manual, have been removed.
- The unit has been opened or disassembled other than as explained in this manual.
- The unit's serial number has been altered, erased, or removed.
- The unit has been misused, neglected, or damaged by accident.
- The component experienced wear and tear due to direct contact with a workpiece or an obstacle.

This warranty is in lieu of all other warranties expressed, implied, or statutory, including, but not limited to, the implied warranties of merchantability and fitness for a particular purpose. In no event shall Robotiq be liable for special, incidental, or consequential damages.

Robotiq shall not be liable for damages resulting from the use of the Palletizing Solution, nor shall Robotiq be responsible for any failure in the performance of other items to which the Palletizing Solution is connected or the operation of any system of which the Palletizing Solution may be a part.

Exclusions

This warranty excludes failure resulting from: improper use or installation, normal wear and tear, accident, abuse, neglect, fire, water, lightning or other acts of nature, causes external to the Palletizing Solution or other factors beyond Robotiq's control. It also excludes all consumable parts, such as suction cups, and their normal wear.

Robotiq reserves the right to make changes in the design or construction of any of its products at any time without incurring any obligation to make any changes whatsoever on units already purchased.



11. Harmonized Standards

11.1. EC Declaration of Incorporation

11.1.1. Robotiq Palletizing Solution



EC Declaration of Incorporation (Original)

In accordance with the EC Machinery Directive 2006/42/EC, Annex II, 1., Section B.

We, the manufacturer:

Robotiq Inc.
966 Chemin Olivier, Suite 500
Lévis, Québec, Canada, G7A 2N1

hereby declares, under sole responsibility, that the product:

Robotiq Palletizing Solution – PE Series (PE10 & PE20)

All serial number
(and accessories)

complies with the following essential requirements of the European Directive 2006/42/EC on machinery:

1.1.2, 1.1.3, 1.1.5, 1.2.1, 1.2.3, 1.2.6, 1.3.1, 1.3.2, 1.3.4, 1.5.1, 1.5.5, 1.5.6, 1.6.1, 1.7.2.

The product is considered as partly completed machinery and has been evaluated in accordance with the following harmonised standards:

- EN ISO 12100:2010
- ISO 4414:2010.

The product must not be put into service until the final machinery into which it is to be incorporated has been declared in conformity with the provisions of the Directive 2006/42/EC, including amendments.

The manufacturer declares that the product complies with the following European Directives and harmonised standards:

- **2014/35/EU (Low Voltage Directive)**
 - EN 60204-1:2018
- **2011/65/EU + 2015/863 (RoHS Directive)**
 - EN 50581:2012
- **2012/19/EU (WEEE Directive)**
 - EN 50419:2005.

The manufacturer also declares the use of these other technical standards, as far as applicable:

ISO 9409-1:2004.

Name and address of the person authorised to compile the relevant technical documentation:

Leif Möller,
9 Blvd. des Droits de l'Homme,
69120 Vaulx-en-Velin, France

The relevant technical documentation is compiled in accordance with part B of Annex VII of Directive 2006/42/EC and will be presented electronically by the manufacturer to competent national authorities, if required with a substantiated reason.

Signed in Lévis on 2023-09-07.

Louis-Alexis Allen Demers, ing., Eng., Ph. D.
Technical Director



11.1.2. PowerPick20 Vacuum Gripper (Optional)



EC Declaration of Incorporation (Original)

In accordance with the EC Machinery Directive 2006/42/EC, Annex II, 1., Section B.

We, the manufacturer:

Robotiq Inc.
966 Chemin Olivier, Suite 500
Lévis, Québec, Canada, G7A 2N1

hereby declares, under sole responsibility, that the product:

PowerPick Vacuum Gripper (PowerPick10 & PowerPick20)
All serial number
(and accessories)

complies with the following essential requirements of the European Directive 2006/42/EC on machinery:

1.1.2, 1.1.3, 1.1.5, 1.3.2, 1.3.4, 1.5.1, 1.5.2, 1.5.3, 1.5.4, 1.5.8, 1.5.10, 1.5.11, 1.7.2.

The product is considered as partly completed machinery and has been evaluated in accordance with the following harmonised standards:

- EN ISO 12100:2010
- ISO 4414:2010

The product must not be put into service until the final machinery into which it is to be incorporated has been declared in conformity with the provisions of the Directive 2006/42/EC, including amendments.

The manufacturer declares that the product complies with the following European Directives and harmonised standards:

- **2014/30/EU (EMC Directive)**
 - EN 61000-6-2:2016
 - EN 61000-6-4:2007 + A1:2011
- **2011/65/EU + 2015/863 (RoHS Directive)**
 - EN 50581:2012
- **2012/19/EU (WEEE Directive)**
 - EN 50419:2005.

The manufacturer also declares the use of these other technical standards, as far as applicable:

ISO 9409-1:2004.

Name and address of the person authorised to compile the relevant technical documentation:

Leif Möller,
9 Blvd. des Droits de l'Homme,
69120 Vaulx-en-Velin, France

The relevant technical documentation is compiled in accordance with part B of Annex VII of Directive 2006/42/EC and will be presented electronically by the manufacturer to competent national authorities, if required with a substantiated reason.

Signed in Lévis on 2023-09-07.

Louis-Alexis Allen Demers, ing., Eng., Ph. D.
Technical Director



11.2. Identification plate

The following identification plate is riveted to the bottom of the Solution's base, conveyor side.

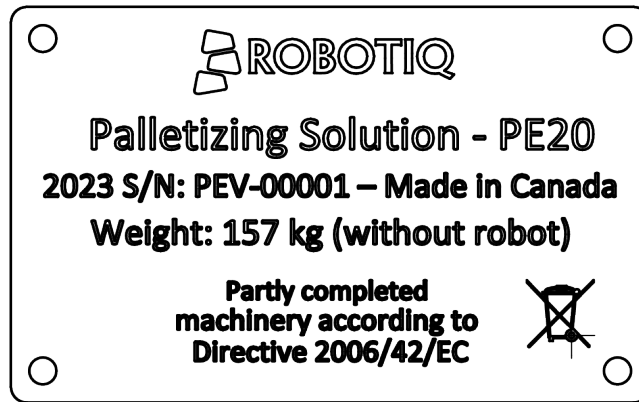

12. Appendix

12.1. Palletizing Cell Layout

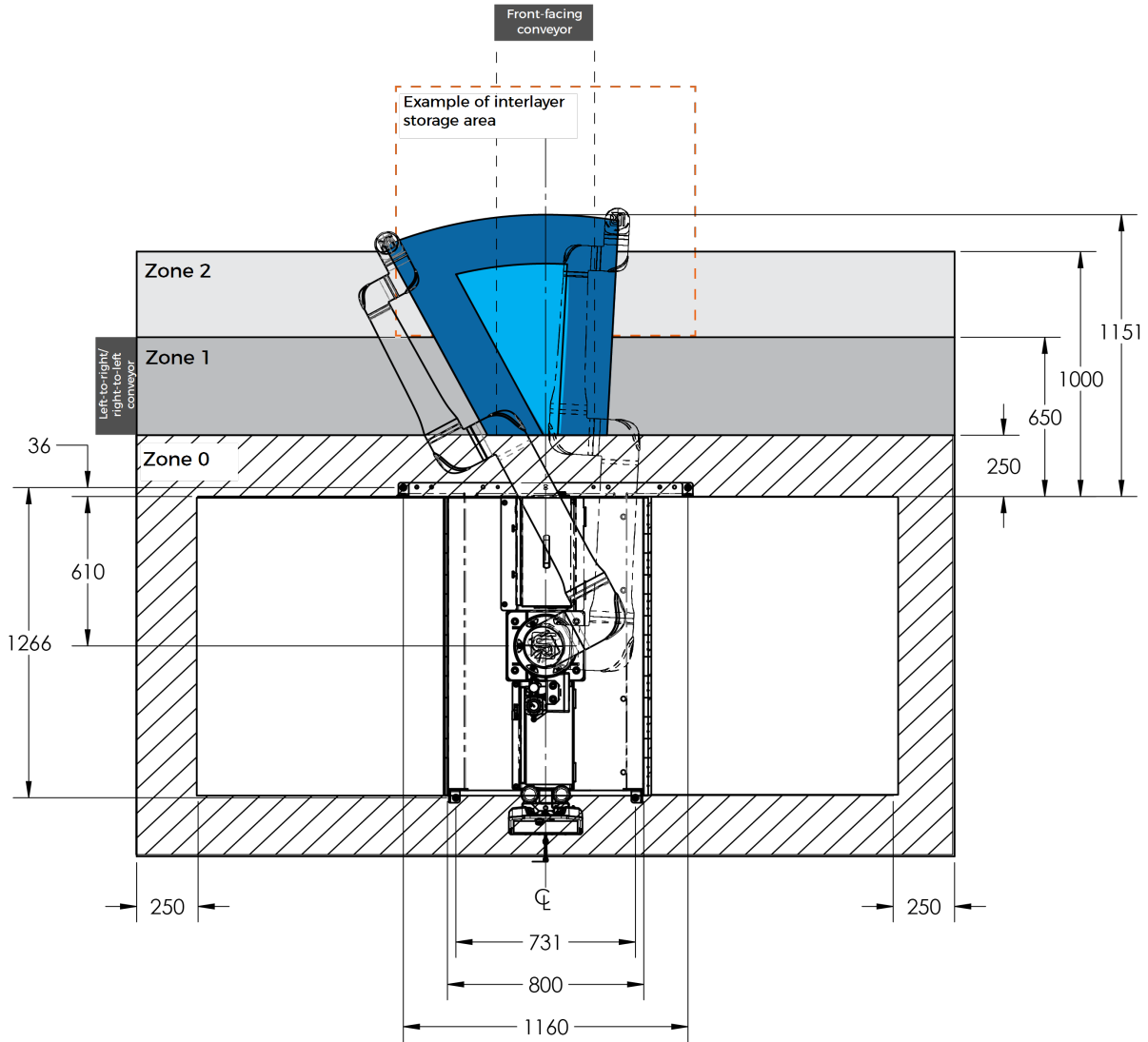



- Picking zone (any Gripper orientation) with 0 mm offset plate
- Picking zone (any Gripper orientation) with 200 mm hollow offset tube

The figure above is a top view of the recommended palletizing cell layout and distances, with the handling of 600 mm x 400 mm x 400 mm (L x W x H) boxes.



ID	PURPOSE
ZONE 0	<p>Approach Zone</p> <p>Zone reserved for approach motion during the box placement process.</p> <p>Keep this zone free of obstacles. Conveyors, safety features and other physical devices should not enter this zone.</p>
ZONE 1	<p>Presentation and Transport Zone</p> <p>Zone used for box presentation (usually via conveyor) and transport to Zone 0 and to the pallet.</p> <p>Physical devices/obstacles can only be present in this zone if they are found at a position lower than the top of the conveyor, and part of the conveyor dimensions defined in the Palletizer node settings</p> <p>Such devices/obstacles may force the robot to take longer trajectories and lower the palletizing speed.</p>
ZONE 2	<p>Extension Zone</p> <p>Same characteristics as Zone 1, but if box length is less than 400 mm, obstacles can be present.</p>

	 CAUTION
	<p>Failure to follow this recommended layout may result in the inability to operate the Solution.</p> <p>The dimensions found in the figure are conservative.</p> <p>If for any reason it is impossible for the user to implement this layout, please contact Robotiq's application experts for assistance and support.</p> <p>Please note that depending on the outcome of the risk assessment, the user may have to define safeguard zones around the system. These zones should be accounted for in the layout.</p>



12.2. Conveyor Positioning Holes



NOTICE

The mounting component of the conveyor should be placed directly under the upper lip of the removable stopper to facilitate the removal of the Solution from the anchors.

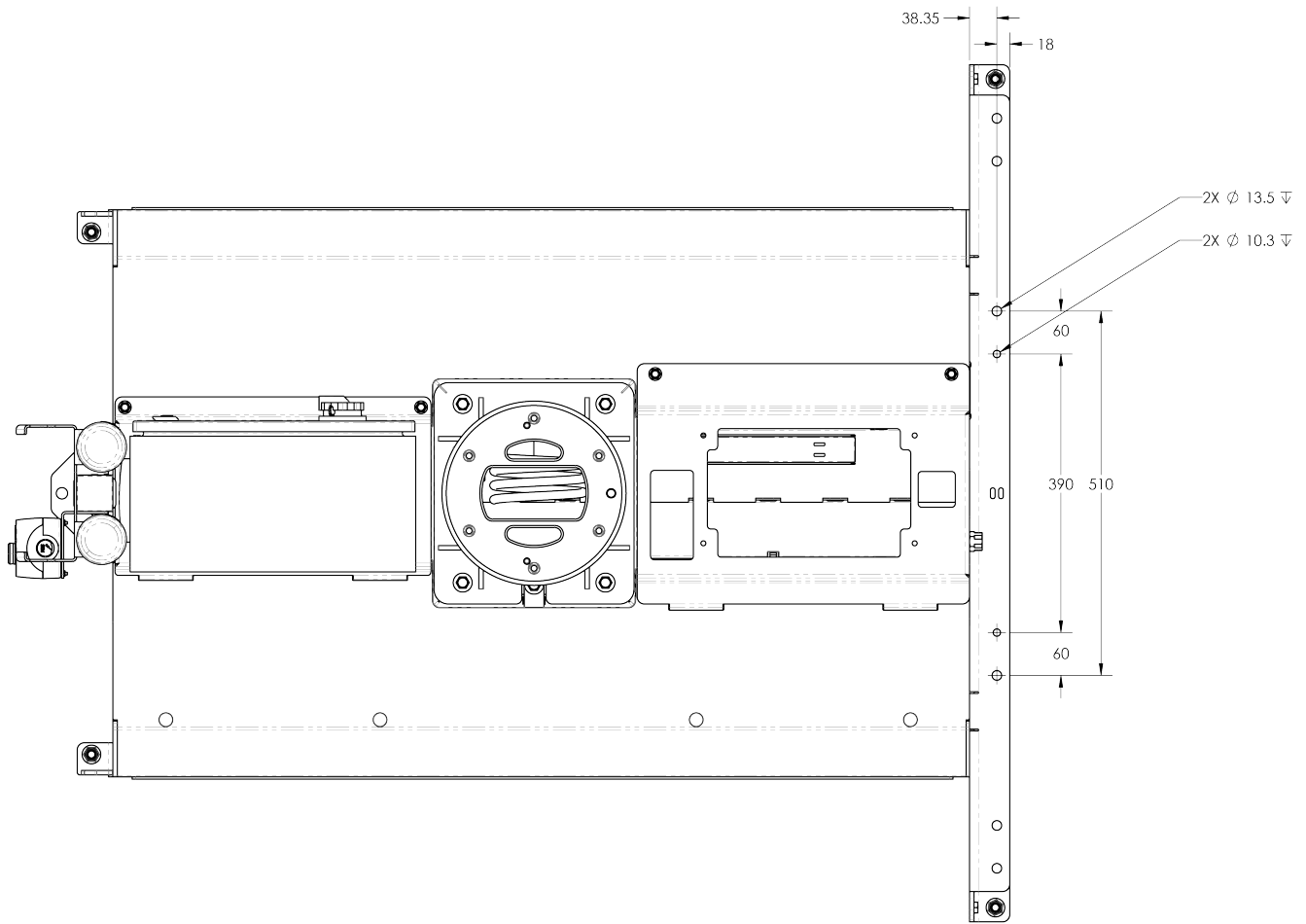

12.3. Overhang Spacers

NOTES:

- 1. THE RESULTING OVERHANG (ON ONE SIDE OF THE PALLET) WILL BE 3 MM LOWER THAN THE VALUE OF X.
- 2. THE DRAWING SHOWS THE TWO OVERHANG SPACERS FOR THE RIGHT (R) PALLET.
- 3. THE TWO SPACERS FOR THE LEFT (L) PALLET MUST BE MIRRORED ALONG A VERTICAL AXIS.

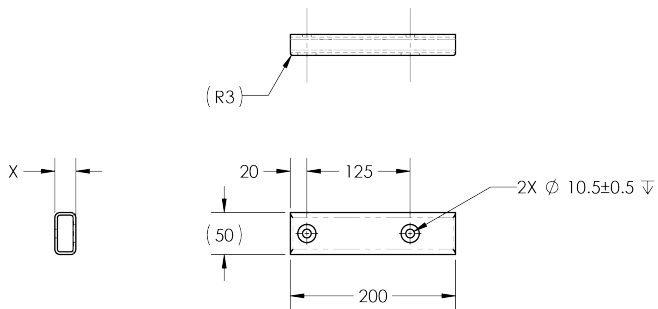
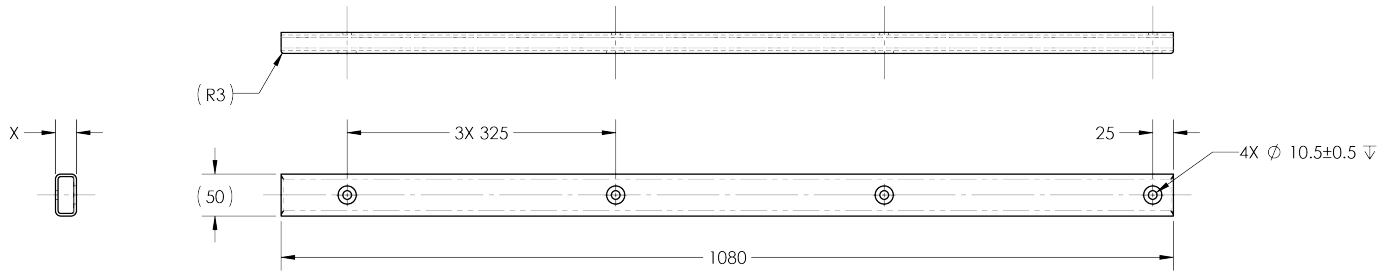

12.4. Pneumatic Diagram

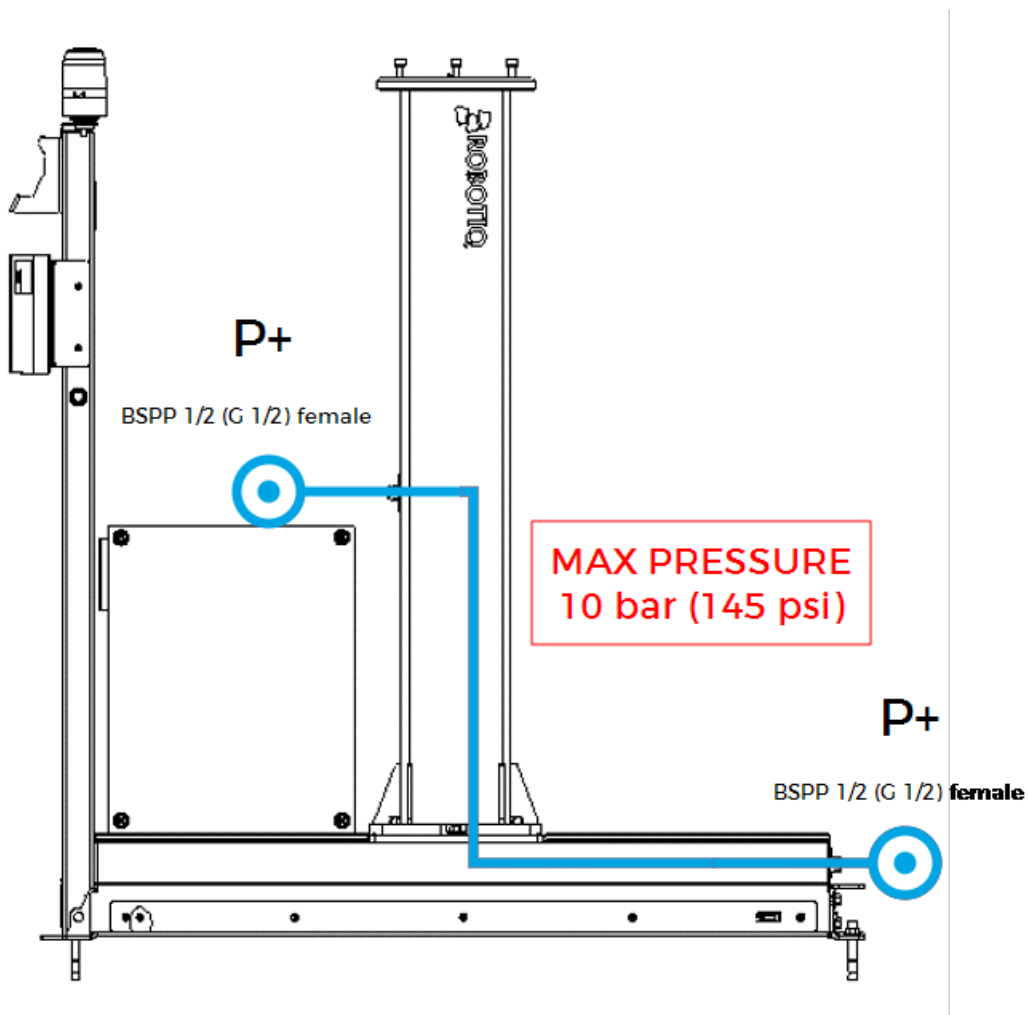

13. Contact

Robotiq

www.robotiq.com

Contact Us

Phone

1-888-ROBOTIQ (762-6847)
(01) 418-380-2788 Outside US and Canada

Technical support and engineering

option 3

Sales

option 2

Head office

Robotiq:
966, chemin Olivier
Suite 500
St-Nicolas, Québec
G7A 2N1
Canada

