



THE JUST-IN-TIME

CONVEYOR TECHNOLOGY



Success is often measured by efficiency and speed. For Robotunits customers this means always keeping one step ahead regarding the time required for delivery, design and assembly.

An important contributor to this is the fact that the Belt Conveyor System is seamlessly integrated into the Modular Automation System.

Advantages like these, as well as great product variety, maximum technical excellence and enormous potential to save time and money in design and assembly, are what makes Robotunits so unique. Special designs are available upon request.



Impressive delivery times

- production time for your individual Belt Conveyor: 1 week
- Just-In-Time delivery



Custom-made sizes

- select any standard frame width between 40 mm and 1200 mm
- select any conveyor length up to 12 m, longer units available upon request
- pre-assembled and height adjustable legs as an option
- fast adjustments to meet your individual requirements



Flexibility in drive options and positions

- choose drive option and position of motor
- maintenance-free timing belt drive
- space saving direct drive



Speed

- standard speed ranges from 2.6 m/min to 58 m/min
- higher speeds available upon request
- Speed Controller optional



Idler options

- roller diameters of 40 mm, 50 mm or 80 mm
- nose bar (16 mm diameter) for transfer of small parts



Wide variety of belts

- accumulation belt
- low & high friction belts
- high durability belts for abrasive and corrosive use



Fully integrated conveyor system

- compatible with all our extrusion sizes
- frame built with standard extrusion system
- accessible T-slot on 3 sides of the conveyor frame
- this makes it quick and easy to attach accessories or structural elements (i.e. stops) to the machine frame



Save time, cut cost

- shortest lead time
- quick configuration of your custom conveyor
- every Belt Conveyor comes fully assembled and tested
- outstanding price/performance ratio



Safety

- self-adjusting safety guard between the Belt Conveyor roll and the slider bed
- timing belt guard with window for visual inspection
- complete documentation meeting the latest Machinery Directive

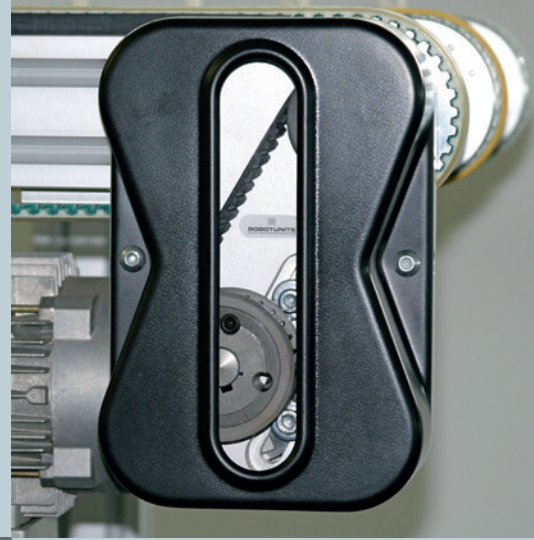

Just-In-Time Conveyor Technology

Belt Conveyor

Page 10

<p>Belt Conveyors 40 C4N</p>  <p>P. 12</p>	<p>Belt Conveyors 50 C5N</p>  <p>P. 14</p>	<p>Belt Conveyors 80 C8N</p>  <p>P. 16</p>	<p>Stand for C4N/C5N C4F</p>  <p>P. 18</p>	<p>Stand for C8N/C8M C8F</p>  <p>P. 19</p>
---	---	---	--	---





Modular Belt Conveyors

Page 20

<p>Straight Modular Belt Conveyors C8M</p>  <p>P. 22</p>	<p>Curved Modular Belt Conveyors C8M</p>  <p>P. 24</p>	<p>Stand for C8N/C8M C8F</p>  <p>P. 19</p>
---	---	---







Timing Belt Conveyors

Page 26

<p>Timing Belt Conveyors 40 C4T</p>  <p>P. 28</p>	<p>Timing Belt Conveyors 80 C8T</p>  <p>P. 30</p>	<p>Stand for C4T C4G</p>  <p>P. 32</p>	<p>Stand for C8T C8G</p>  <p>P. 33</p>
--	--	---	--

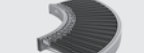
Powered Roller Conveyor

Page 34

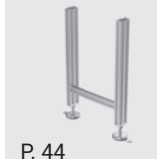
<p>Powered Roller Conveyor Straight R5S</p>  <p>P. 38</p>	<p>Powered Roller Conveyor Merge R5M</p>  <p>P. 39</p>	<p>Powered Roller Conveyor Curved R5C</p>  <p>P. 40</p>	<p>Transfer Unit 90° R5T</p>  <p>P. 41</p>	<p>Turntable R5R</p>  <p>P. 42</p>	<p>Lift Station R5L</p>  <p>P. 43</p>	<p>Stand for R5_</p>  <p>P. 44</p>
--	---	--	---	--	--	---

Side Guide System

Page 46

<p>Side Guide Base COP4561</p>  <p>P. 48</p>	<p>Side Guide Clamp With Rod CO_90_</p>  <p>P. 49</p>	<p>Side Guide Clip COP4570</p>  <p>P. 50</p>	<p>Side Guide End Piece COP4590</p>  <p>P. 50</p>	<p>Side Guide Plastic COL4590</p>  <p>P. 51</p>
---	--	---	---	--

Conveyor Technology Accessory Overview

Page 142

C4N Belt Conveyor Drive Options

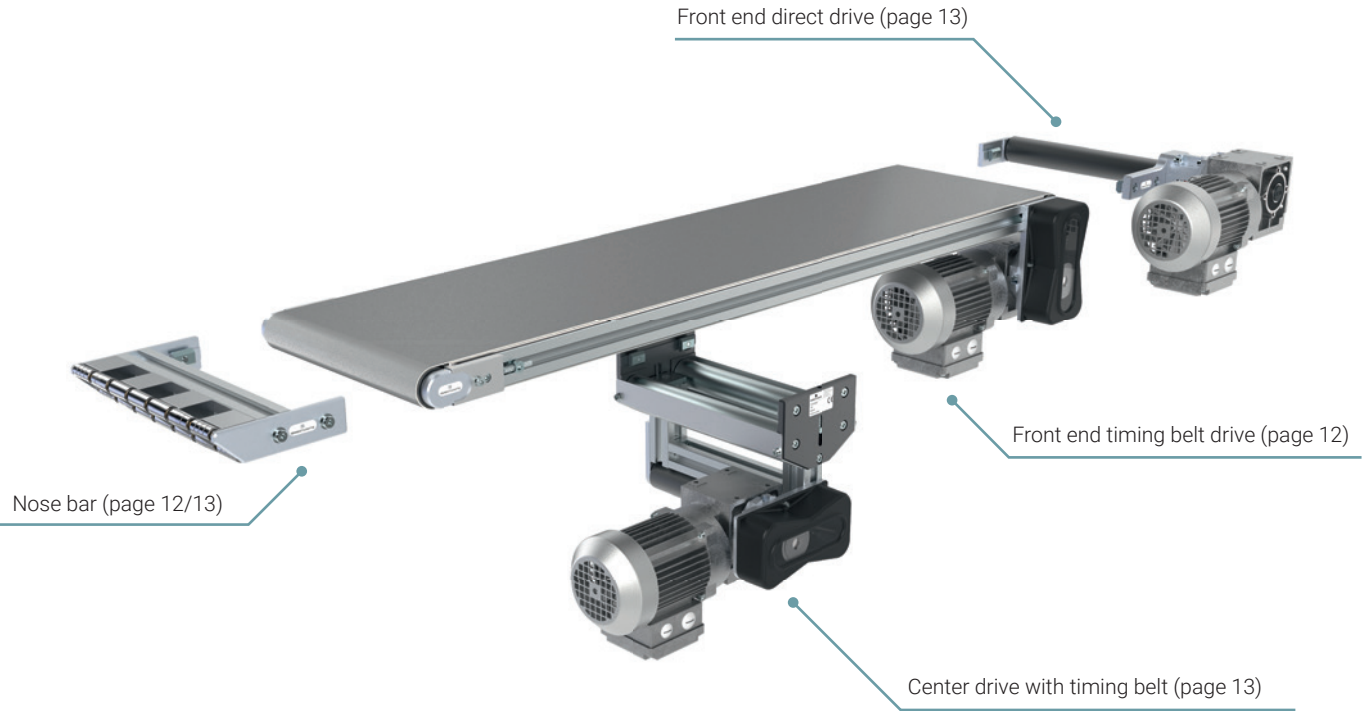

C5N Belt Conveyor Drive Options

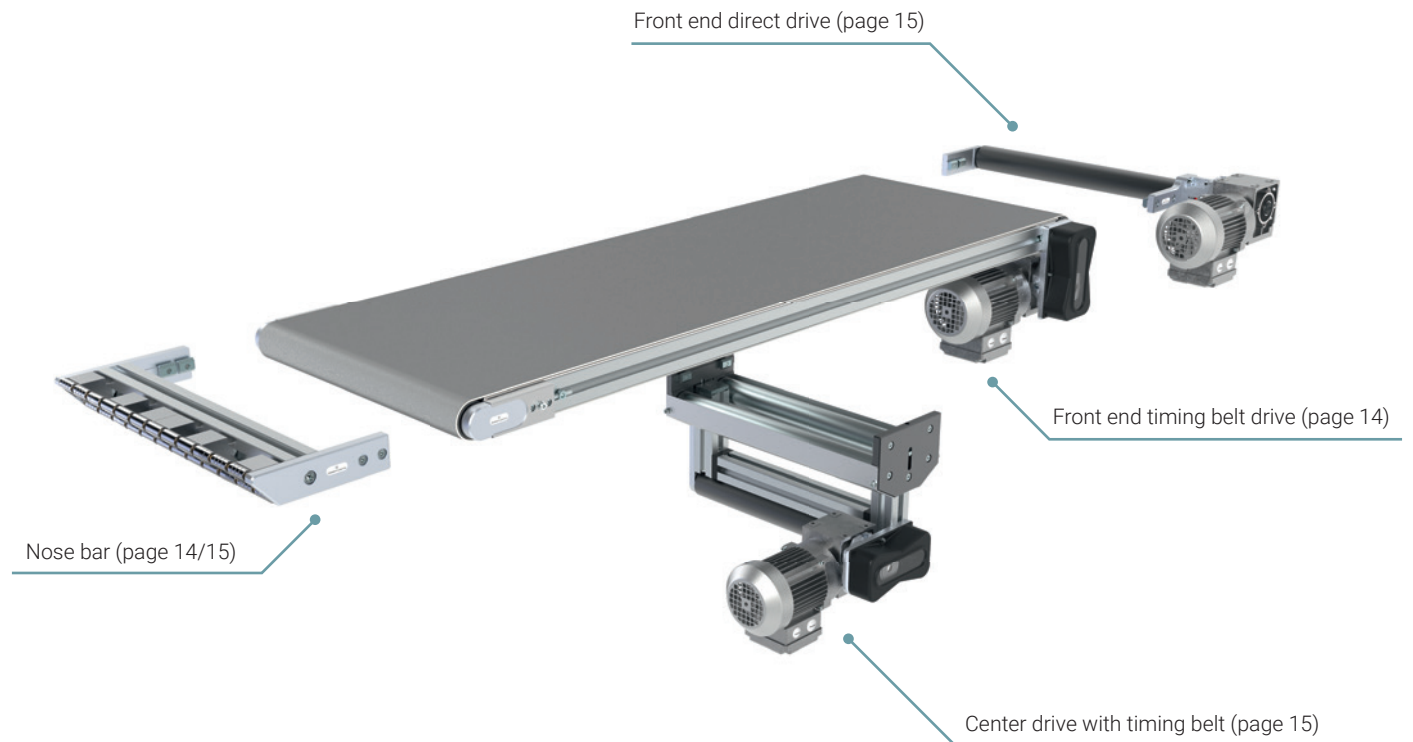

C8N Belt Conveyor Drive Options

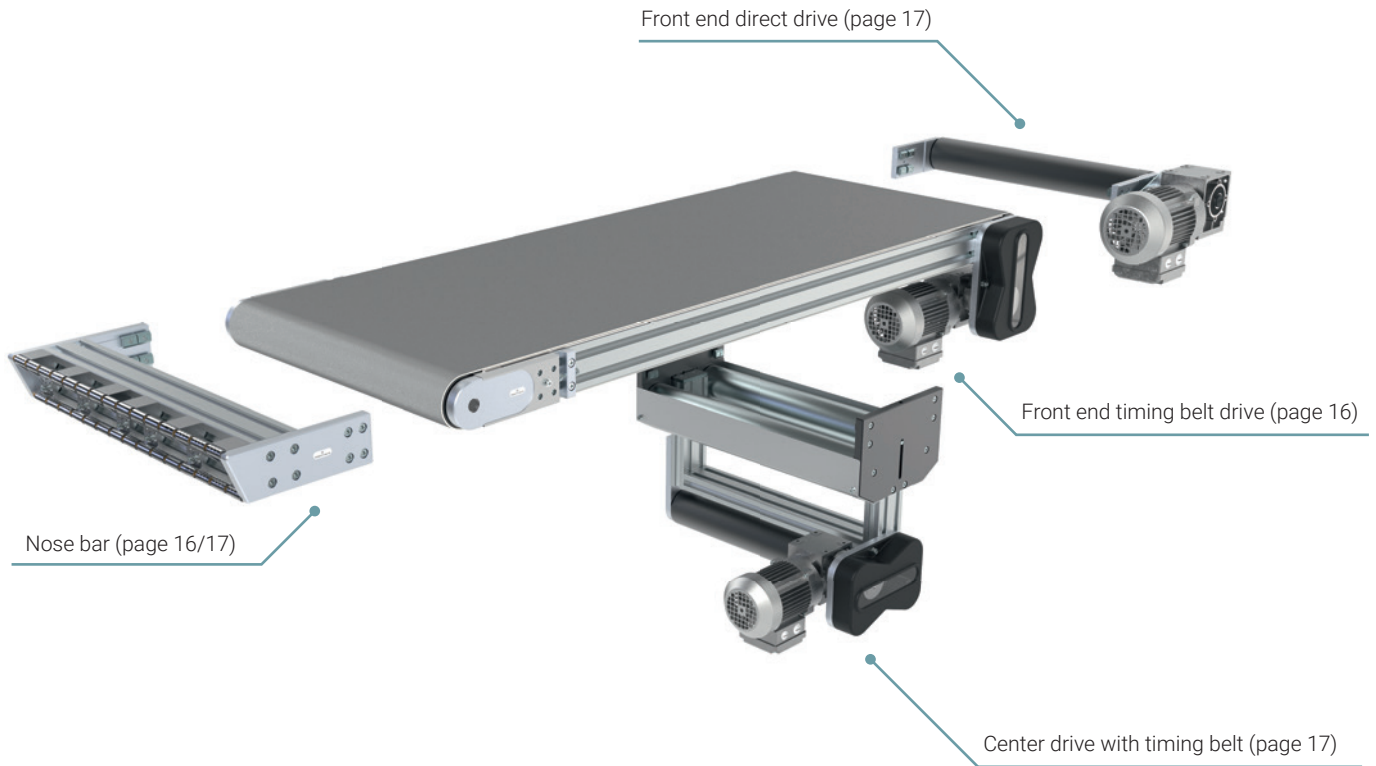



Application

Used for a wide variety of conveying applications

Technical Data

Belt speeds from 3 m/min up to 55 m/min

Drive power depending on belt speed and load ranging from 0.12 kW to 0.37 kW (208-230/460V; 50/60Hz; IP54)
Max. total load of material 240 kg

Belt Type

low friction, high friction, accumulation, food grade, cut & oil resistant, cleated for incline transport, integrated belt side guides, etc.

C4N without side guides

Belt width = frame width - 10 mm

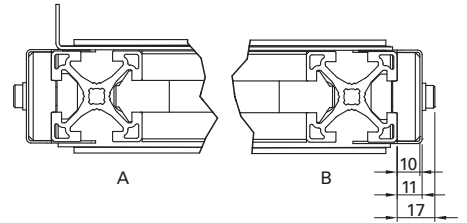
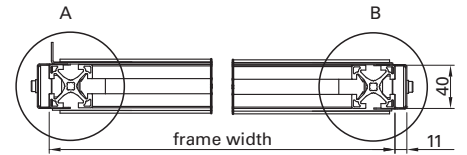

Side Guides for Belt Conveyors see page 46

C4N with side guides

Frame width ≤ 120 mm

Belt width = frame width - 15 mm

Frame width > 120 mm

Belt width = frame width - 20 mm

Drive Option¹

Front End Timing Belt Drive

- A** Front end timing belt drive, left
- B** Front end timing belt drive, right
- C** Front end timing belt drive, left, tail end nose bar
- D** Front end timing belt drive, right, tail end nose bar

Front End Direct Drive

- E** Front end direct drive left
- F** Front end direct drive, right
- G** Front end direct drive, left, with tail end nose bar
- H** Front end direct drive, right, with tail end nose bar

Center Drive With Timing Belt

- K** Center drive with timing belt
- L** Center drive with timing belt and front end nose bar
- N** Center drive with timing belt and tail end nose bar
- Q** Center drive with timing belt and nose bar on both ends

Front End Timing Belt Drive

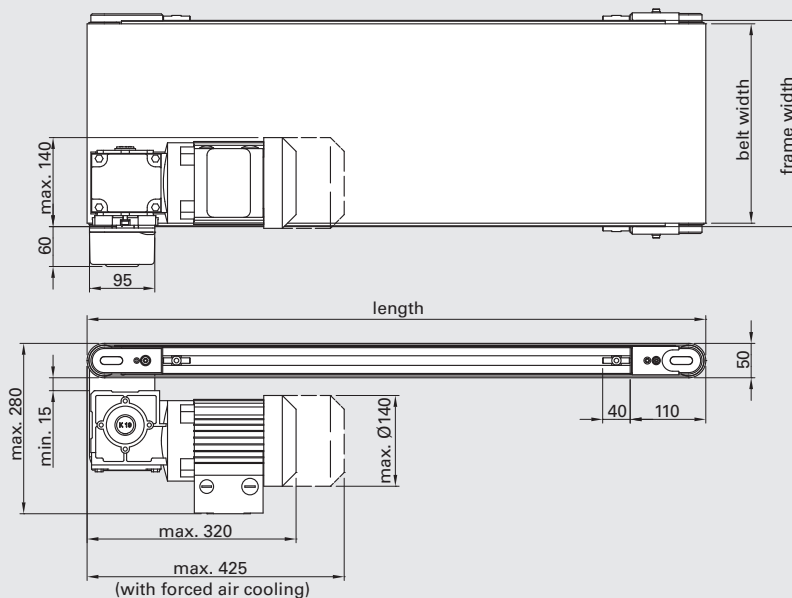

Optional: nose bar

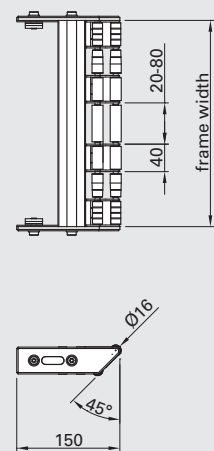

1) Standard direction is pulling. The running direction of all drives can be changed by reversing the polarity of the motor.

Drawing dimensions in mm

Front End Direct Drive

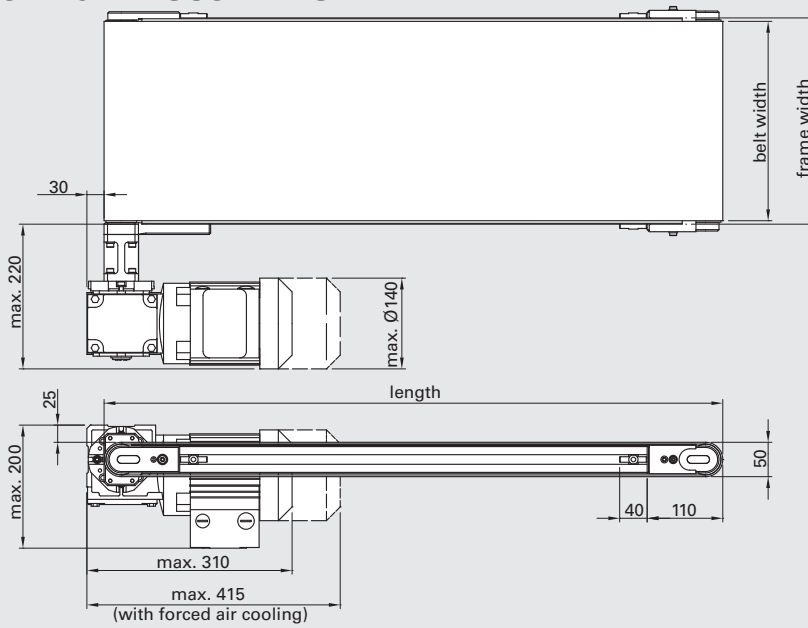

Optional: nose bar

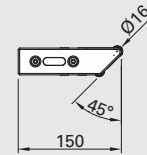
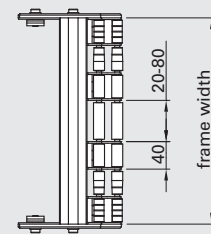

Center Drive With Timing Belt

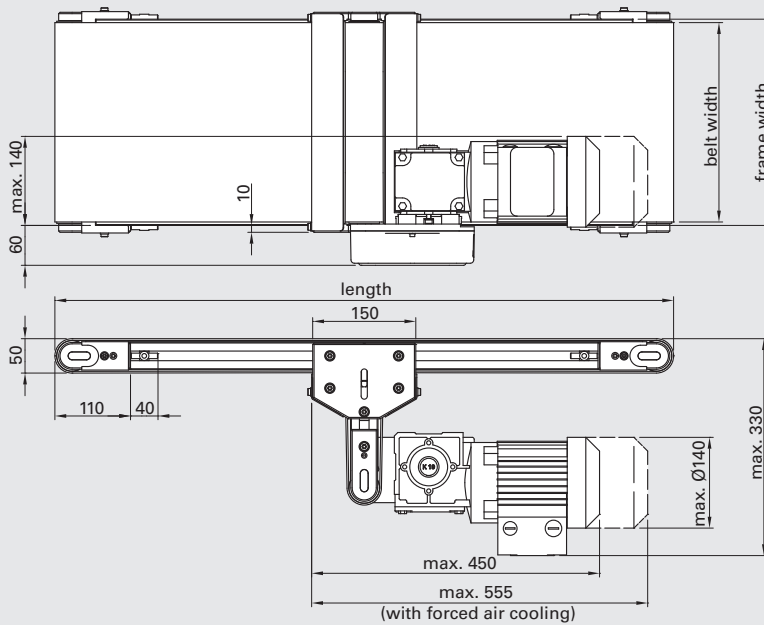

Optional: nose bar

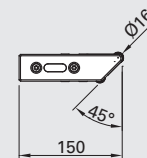
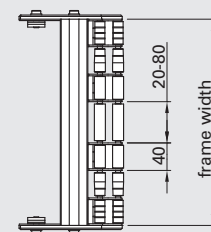

Standard Widths And Lengths²

Description	Frame Width	Max. length
Belt Conveyor 40	40 mm	12000 mm
Belt Conveyor 40	80 mm	12000 mm
Belt Conveyor 40	120 mm	12000 mm
Belt Conveyor 40	160 mm	12000 mm

Description	Frame Width	Max. length
Belt Conveyor 40	200 mm	12000 mm
Belt Conveyor 40	240 mm	12000 mm
Belt Conveyor 40	300 mm	12000 mm
Belt Conveyor 40	400 mm	12000 mm

Please note the minimum length to width ratio of 1.5:1.

Request For Quote / Order

Please use our Belt Conveyor configuration tool or our request form at www.robotunits.com

2) Special widths and special lengths are available upon request.
Drawing dimensions in mm

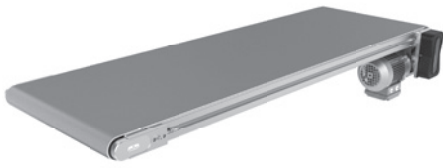

Application

Used for a wide variety of conveying applications

Technical Data

Belt speeds from 3 m/min up to 67 m/min

Drive power depending on belt speed and load ranging from 0.12 kW to 0.37 kW

(208-230/460V; 50/60Hz; IP54)

Max. total load of material 340 kg

Belt Type

low friction, high friction, accumulation, food grade, cut & oil resistant, cleated for incline transport, integrated belt side guides, etc.

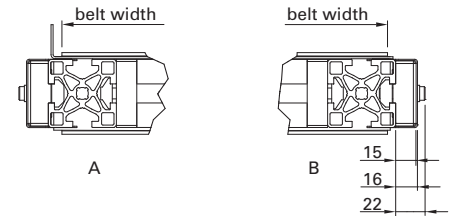
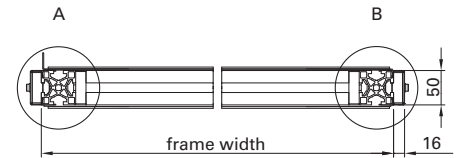

Side Guides for Belt Conveyors see page 46

$Belt\ width = frame\ width - 20\ mm$

Drive Option¹

Front End Timing Belt Drive

- A Front end timing belt drive, left
- B Front end timing belt drive, right
- C Front end timing belt drive, left, tail end nose bar
- D Front end timing belt drive, right, tail end nose bar

Front End Direct Drive

- E Front end direct drive left
- F Front end direct drive, right
- G Front end direct drive, left, with tail end nose bar
- H Front end direct drive, right, with tail end nose bar

Center Drive With Timing Belt

- K Center drive with timing belt
- L Center drive with timing belt and front end nose bar
- N Center drive with timing belt and tail end nose bar
- Q Center drive with timing belt and nose bar on both ends

Front End Timing Belt Drive

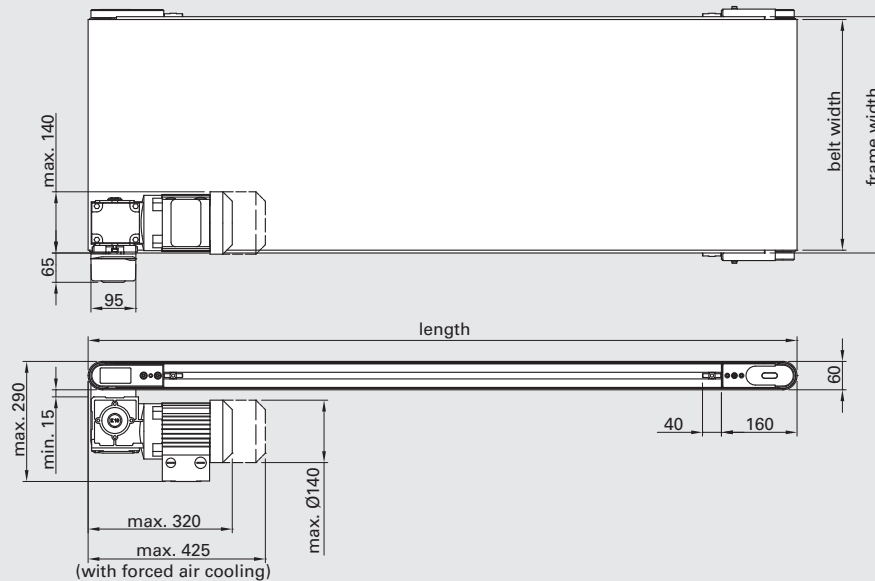

Optional: nose bar

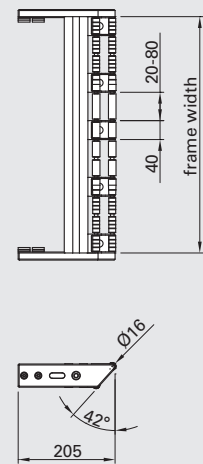

1) Standard direction is pulling. The running direction of all drives can be changed by reversing the polarity of the motor.
Drawing dimensions in mm

Front End Direct Drive

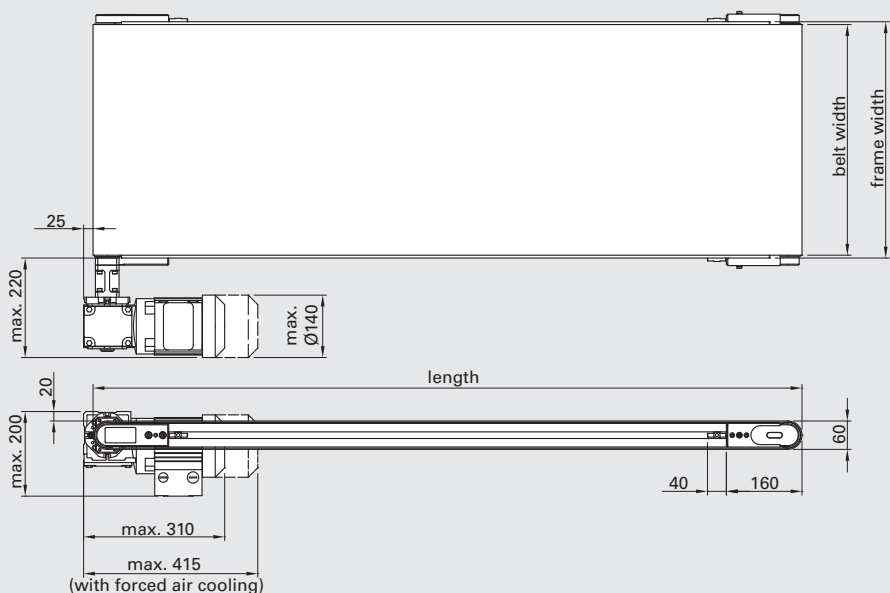

Optional: nose bar

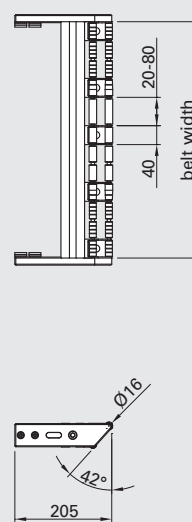

Center Drive With Timing Belt

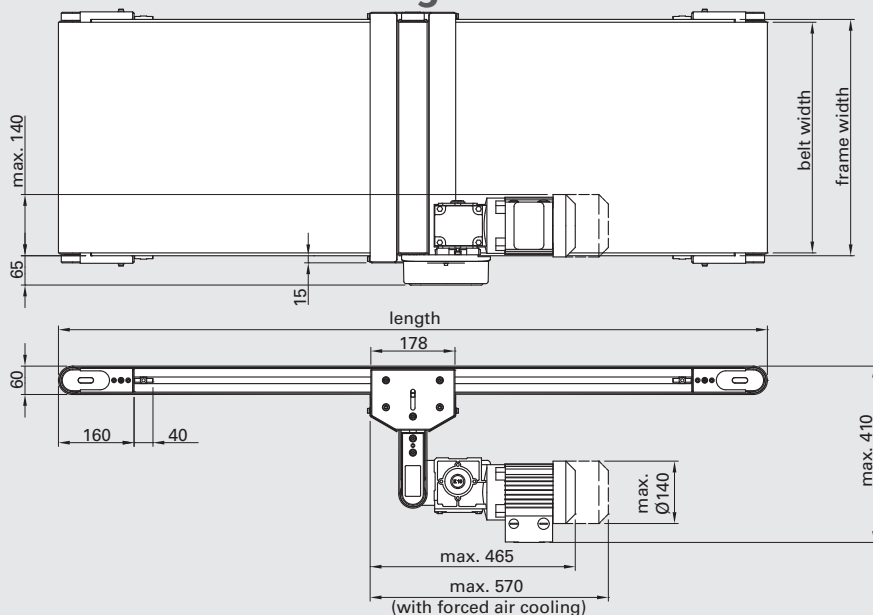

Optional: nose bar

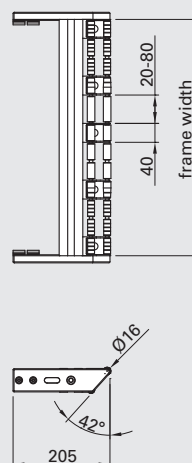

Standard Widths And Lengths²

Description	Frame Width	Max. length
Belt Conveyor 50	400 mm	12000 mm
Belt Conveyor 50	500 mm	12000 mm
Belt Conveyor 50	600 mm	12000 mm

Design Options

Side view



Please note the minimum length to width ratio of 1.5:1.

Request For Quote / Order

Please use our Belt Conveyor configuration tool or our request form at www.robotunits.com

2) Special widths and special lengths are available upon request.
Drawing dimensions in mm



Application

Used for a wide variety of conveying applications

Technical Data

Belt speeds from 5 m/min up to 65 m/min

Drive power depending on belt speed and load ranging from 0.25 kW to 0.55 kW (208-230/460V; 50/60Hz; IP54)
Max. total load of material 800 kg

Belt Type

low friction, high friction, accumulation, food grade, cut & oil resistant, cleated for incline transport, integrated belt side guides, etc.

$Belt\ width = frame\ width - 20\ mm$

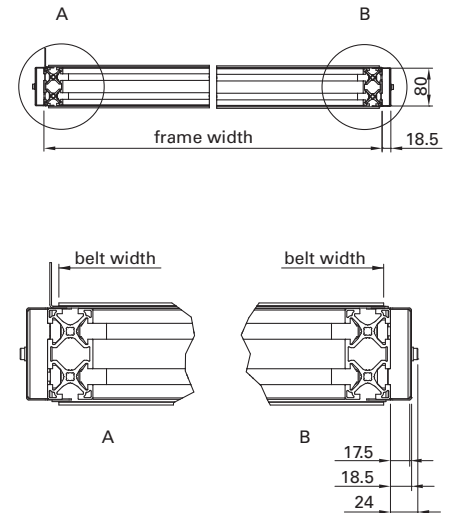

Side Guides for Belt Conveyors see page 46

Drive Option¹

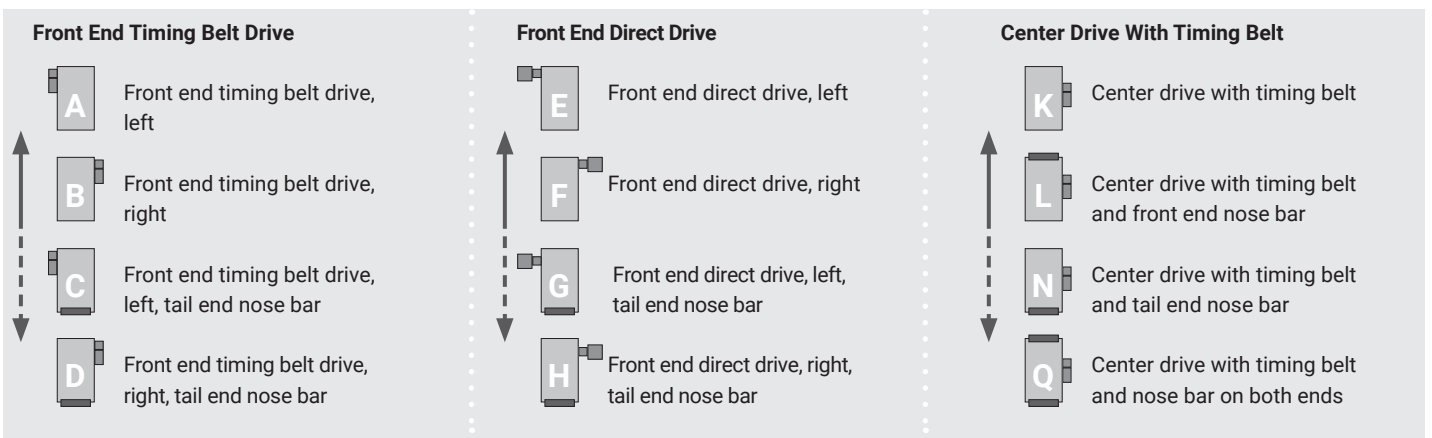

Front End Timing Belt Drive

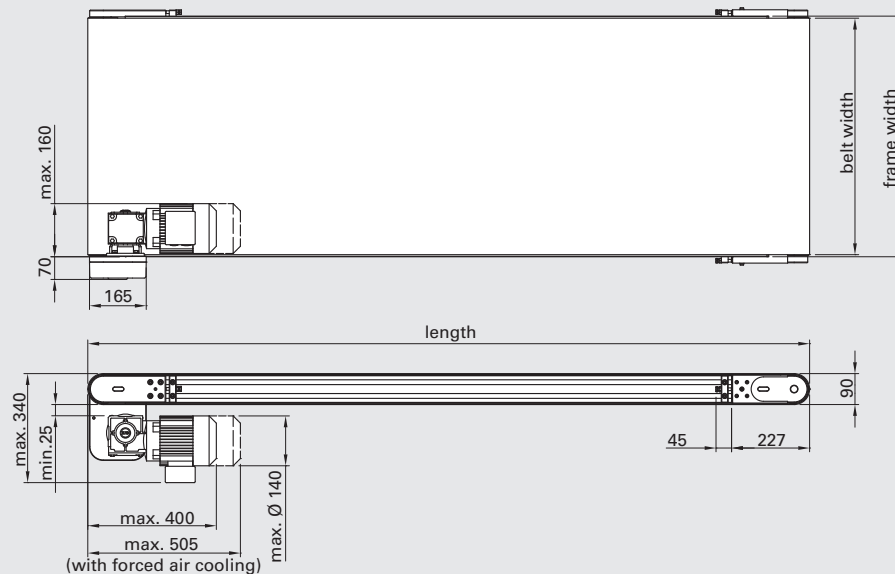

Optional: nose bar

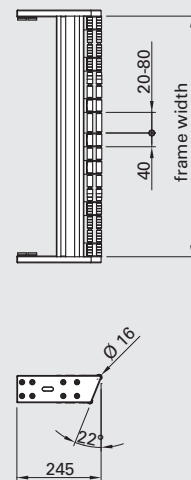

1) Standard direction is pulling. The running direction of all drives can be changed by reversing the polarity of the motor.
Drawing dimensions in mm

Front End Direct Drive

Optional: nose bar

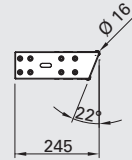
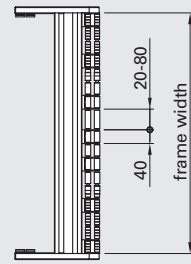
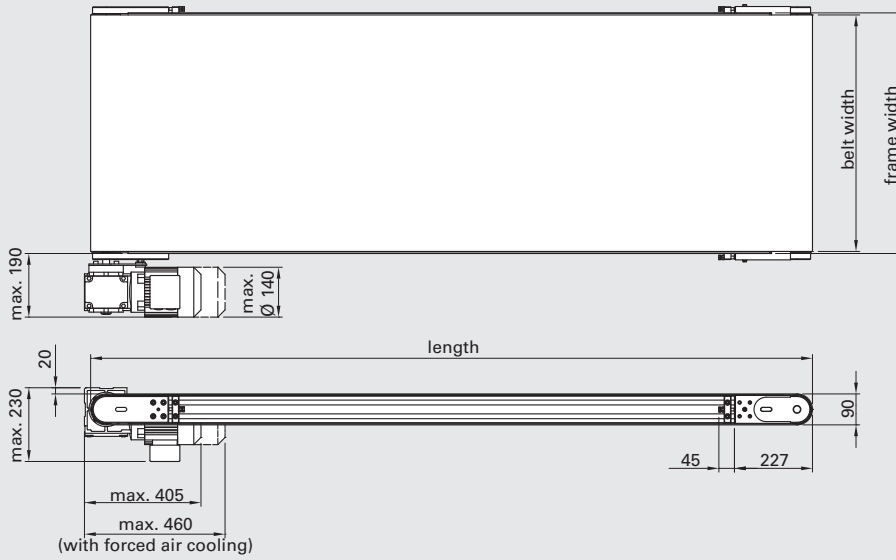

Center Drive With Timing Belt

Optional: nose bar

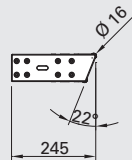
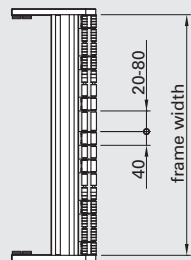
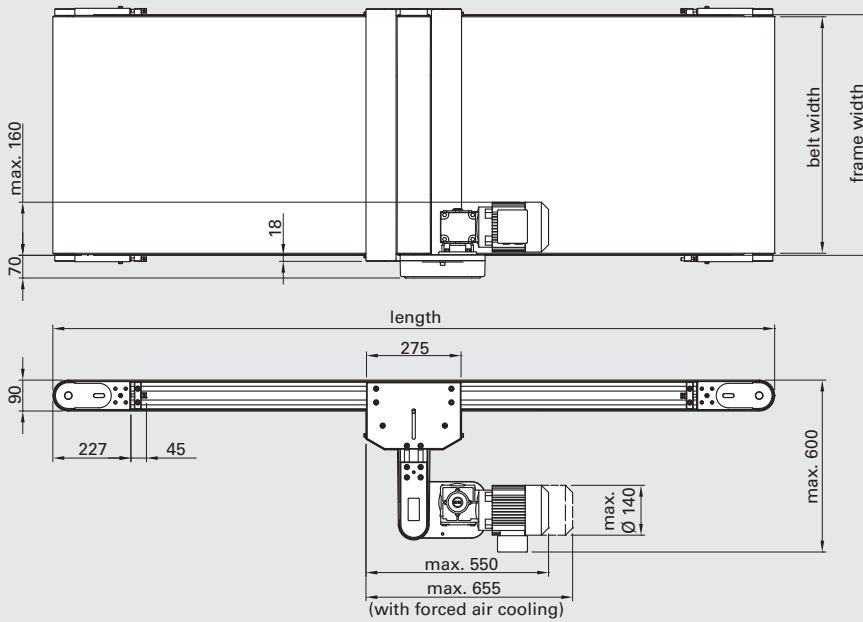

Standard Widths And Lengths²

Description	Frame Width	Max. length
Belt Conveyor 80	600 mm	12000 mm
Belt Conveyor 80	700 mm	12000 mm
Belt Conveyor 80	800 mm	12000 mm
Belt Conveyor 80	1000 mm	12000 mm
Belt Conveyor 80	1200 mm	12000 mm

Design Options

Side view



Please note the minimum length to width ratio of 1.5:1.

Request For Quote / Order

Please use our Belt Conveyor configuration tool or our request form at www.robotunits.com

2) Special widths and special lengths are available upon request.
Drawing dimensions in mm

C4F

Stand for C4N/C5N

**Application**

Stand for Belt Conveyor 40 and 50

Technical Data

Material: clear anodized aluminum;
galvanized GD-Zn; galvanized steel; rubber

Scope of Delivery

Stand segment fully assembled and
attached to belt conveyor if applicable

Wide conveyor stand offers additional
stability when conveyor heights exceed
3 times the frame width.

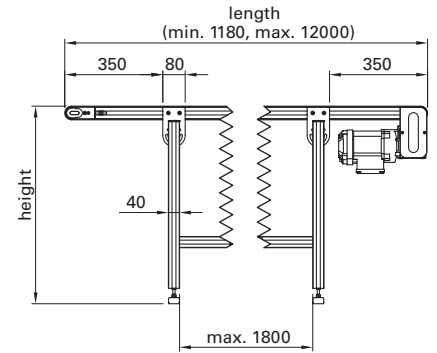

Standard Conveyor Stands

Wide Conveyor Stands

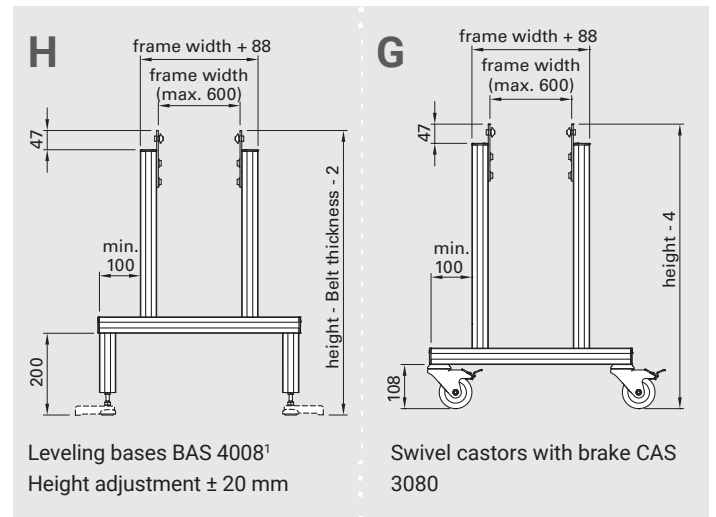
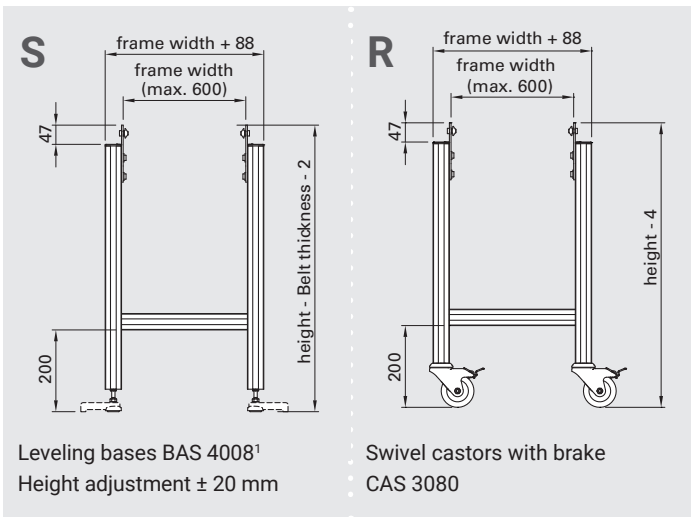

Order Code

Description	Order Code ²			
	Frame Width	Type	Length	Height
Stand for C4N/C5N	---	- NN	---	---

1) Optionally with Floor Mounting Plate BAP 4500

2) Please complete the order code by adding the corresponding parameters for order processing.

Drawing dimensions in mm

C8F

Stand for C8N/C8M



Application
Stand for Belt Conveyor 80 and Modular Belt Conveyor 80

Technical Data
Material: clear anodized aluminum; galvanized GD-Zn; galvanized steel; rubber

Scope of Delivery
Stand segment fully assembled and attached to belt conveyor if applicable

Wide conveyor stand offers additional stability when conveyor heights exceed 3 times the frame width.

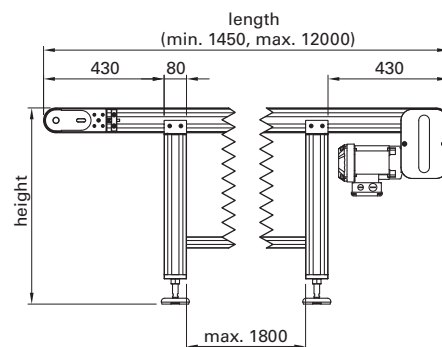

Standard Conveyor Stands

Wide Conveyor Stands

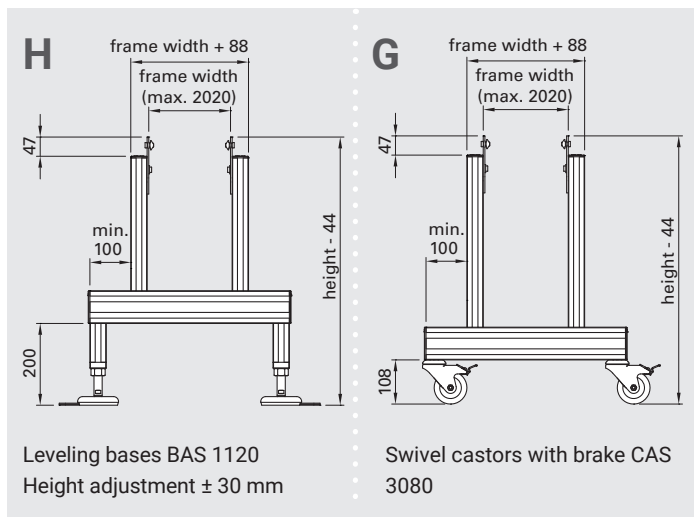
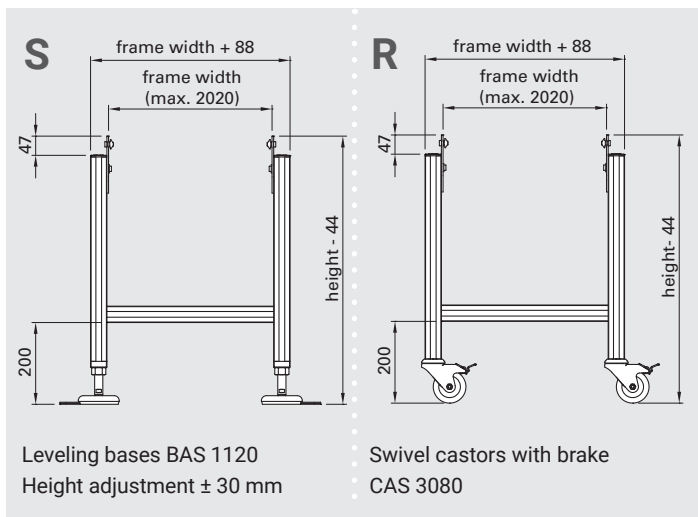

Order Code

Description	Order Code ¹			
	Frame Width	Type	Length	Height
Stand for C8N/C8M	C8F	---	_ NN	---

1) Please complete the order code by adding the corresponding parameters for order processing.

Drawing dimensions in mm

C8M Straight Modular Belt Conveyor Drive Options

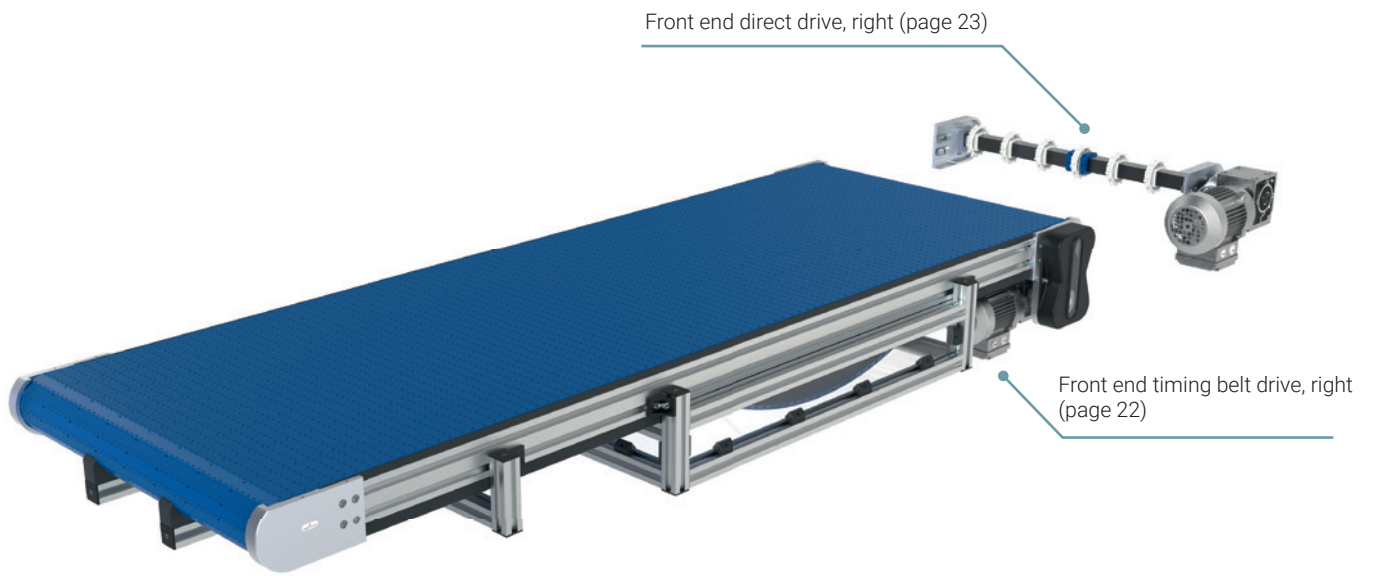

C8M Curved Modular Belt Conveyor Drive Options

Front end direct drive, left (page 25)



Front end timing belt drive, left (page 24)

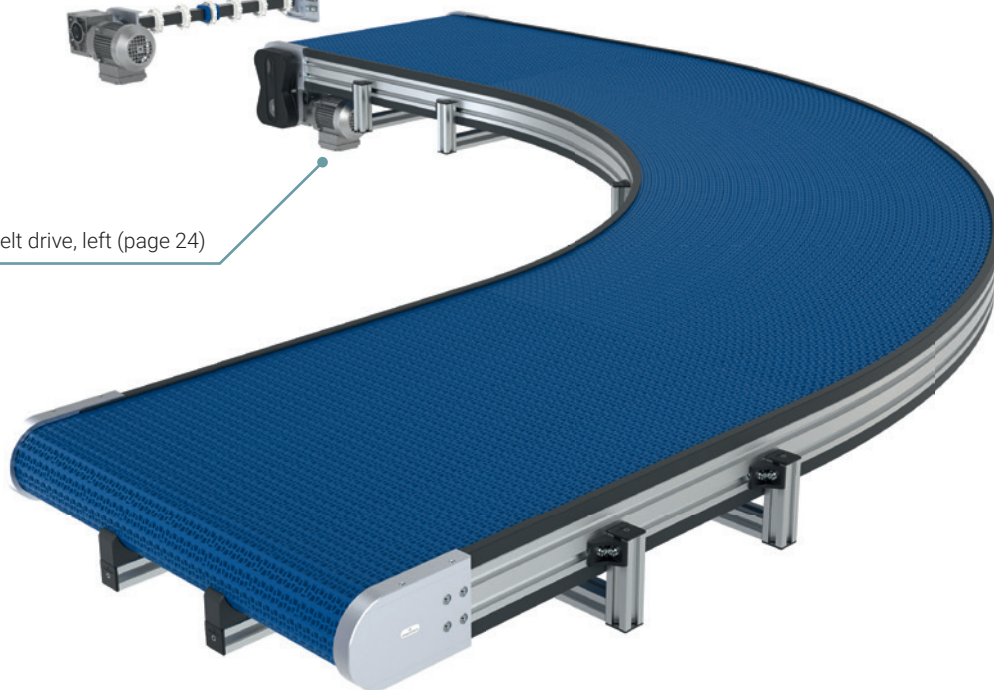



Application

Used for a wide variety of conveying applications

Technical Data

Belt speeds from 6 m/min up to 50 m/min

Drive power depending on belt speed and load ranging from 0.25 kW to 0.55 kW (208-230/460V; 50/60Hz; IP54)
 Max. total load of material 750 kg
 Modular belt pitch 1 inch

Modular belt design

Modular belt open
 Modular belt closed

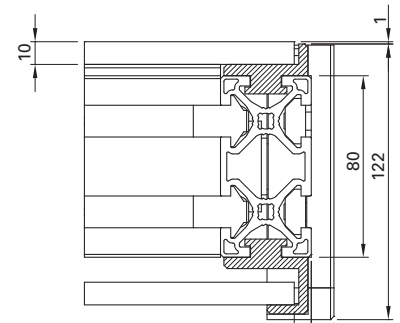

modular belt width (MB)
 frame width (RB)
 $RB = MB + 15$ (RB < 1500)
 $RB = MB + 15$ bis 20 (RB ≥ 1500)

Side Guides for Modular Belt Conveyors see page 46

Drive Option¹

Front End Timing Belt Drive

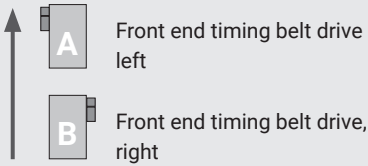

Front End Direct Drive

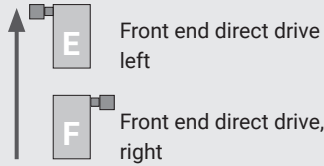

Front End Timing Belt Drive

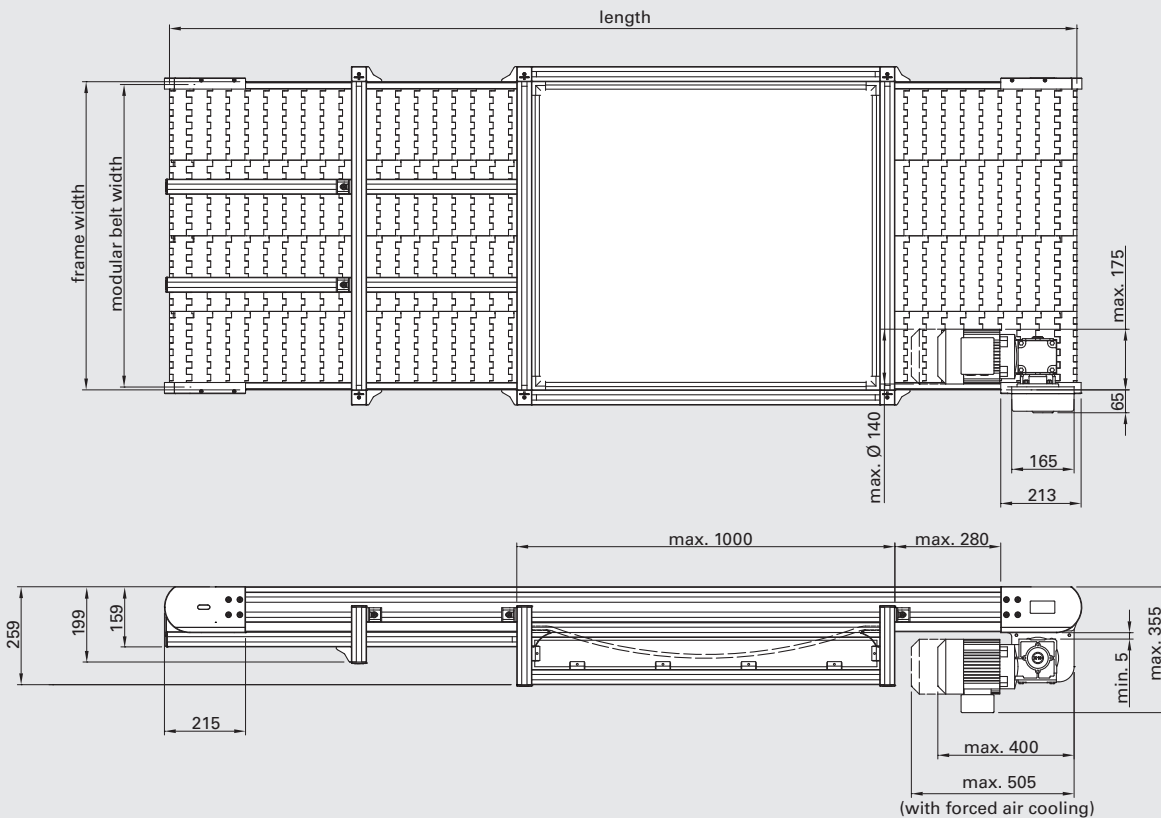

Front End Direct Drive

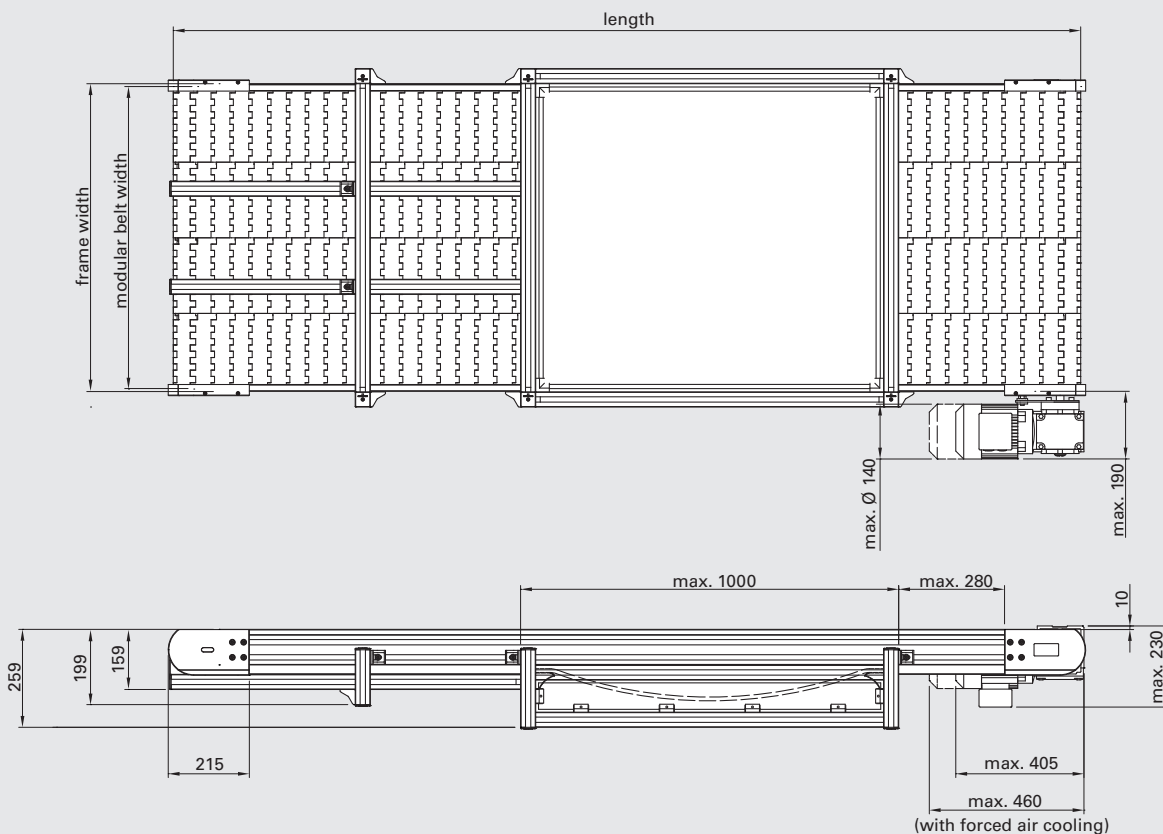

Design Options²

Side view



Length And Frame Width

Description	Min. length ³	Max. length ³	Min. modular belt width ⁴	Max. modular belt width ⁴
C8M Straight front end timing belt drive	1500 mm	12000 mm	150 mm	2000 mm
C8M Straight front end direct drive	1500 mm	12000 mm	150 mm	2000 mm

Request For Quote / Order

Please use our request form at www.robotunits.com.

- 1) Only pulling direction is possible
- 2) Design options on request
- 3) Special lengths are available upon request
- 4) Modular belt widths can be ordered ranging from min. 150 mm to max. 2000 mm in steps of 50 mm.

Drawing dimensions in mm

**Application**

Used for a wide variety of conveying applications

Technical Data

Belt speeds from
6 m/min up to 30 m/min

Drive power depending on belt speed and load ranging from
0.25 kW to 0.55 kW
(208-230/460V; 50/60Hz; IP54)
Maximum load to be conveyed: on request
Modular belt pitch 1 inch

Modular belt design

Modular belt open

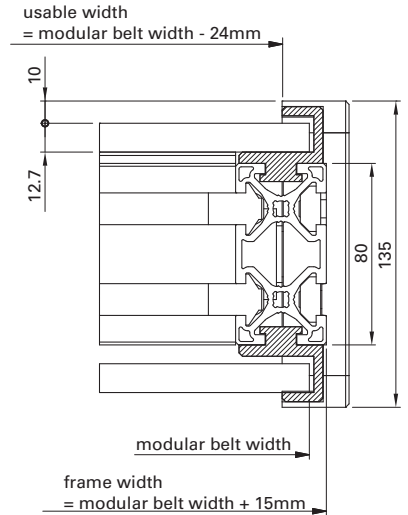

Side Guides for Modular Belt Conveyors
see page 46

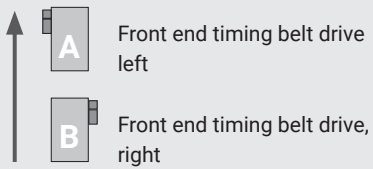
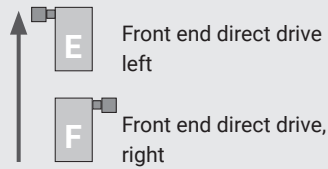
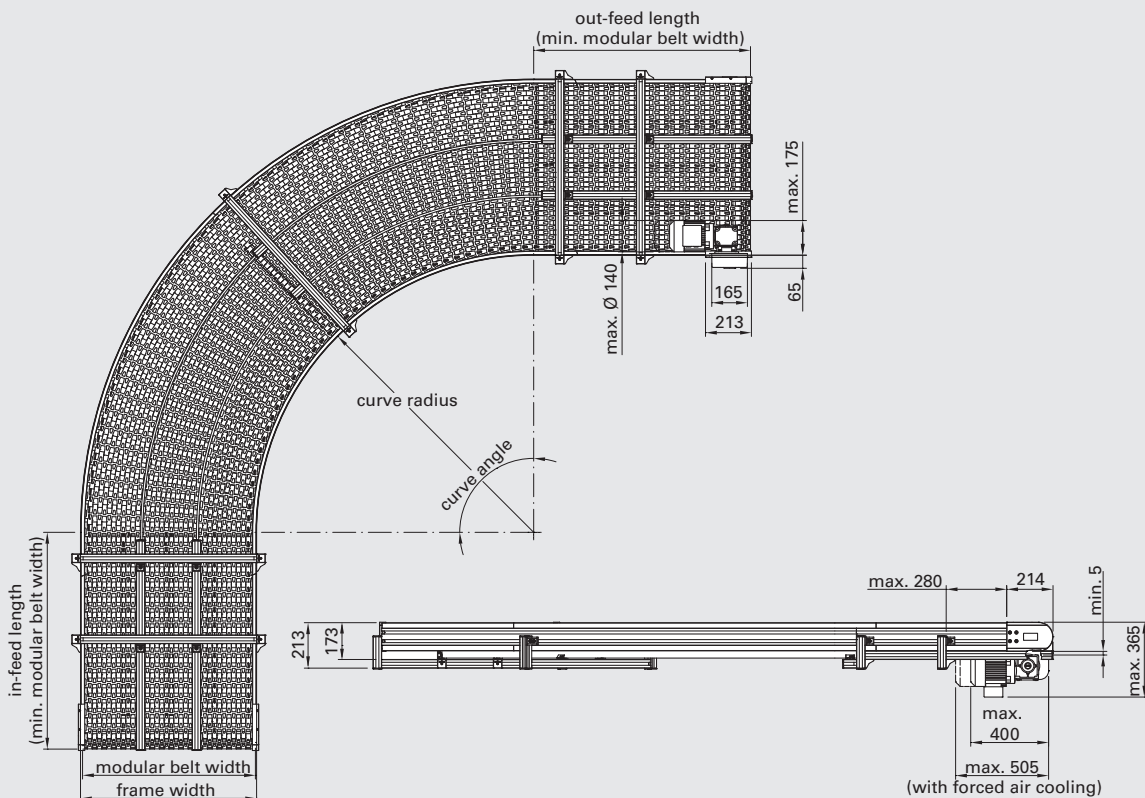
Drive Option¹**Front End Timing Belt Drive****Front End Direct Drive****Front End Timing Belt Drive**

Front End Direct Drive

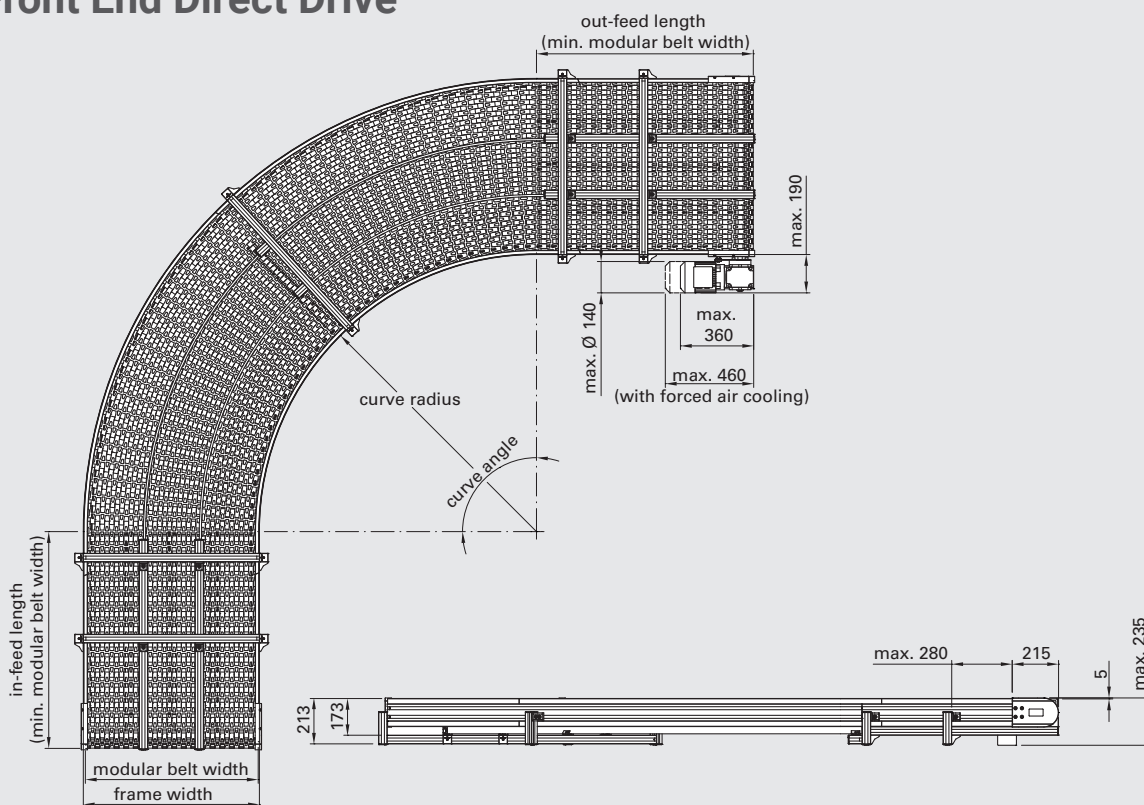

Design Options²

Side view



Top view



Frame Width

Description	Frame width min. ³	Frame width max. ³
C8M Curved front end timing belt drive	215 mm	1215 mm
C8M Curved front end direct drive	215 mm	1215 mm

Request For Quote / Order

Please use our request form at www.robotunits.com.

- 1) Only pulling direction is possible
 - 2) Design options on request
 - 3) Frame widths can be ordered ranging from min. 215 mm to max. 1215 mm in steps of 50 mm.
- Drawing dimensions in mm

C4T Timing Belt Conveyor Drive And Connection Options

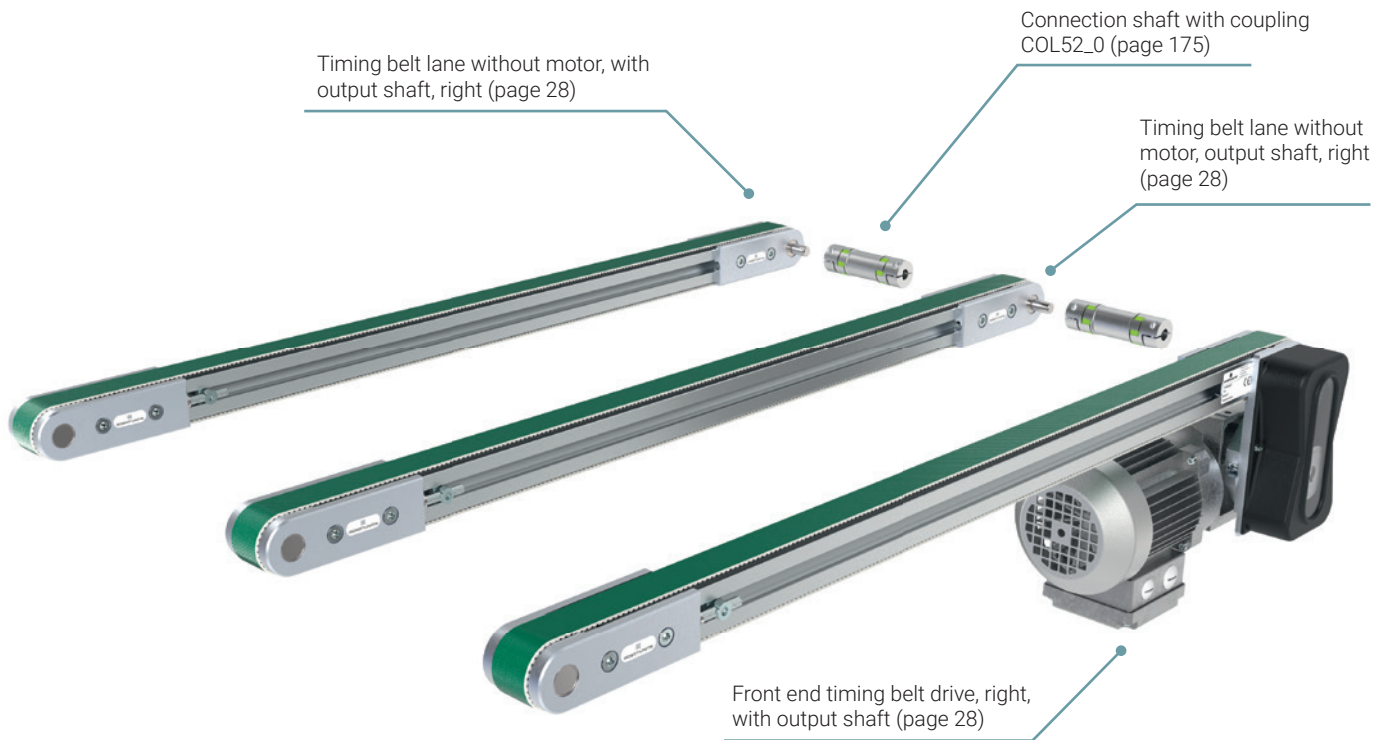

C8T Timing Belt Conveyor Drive And Connection Options

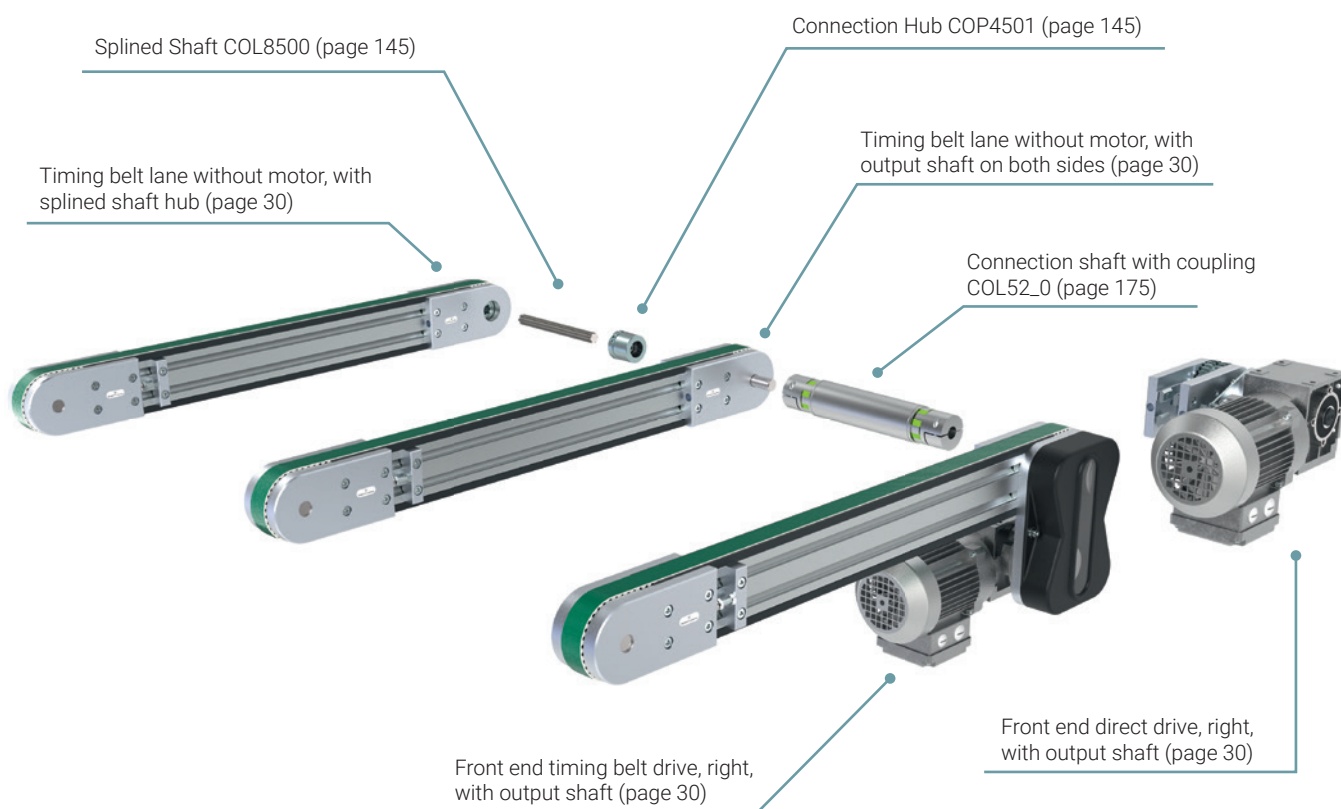

**Application**

Used for a wide variety of conveying applications

Technical Data

Speeds from 3 m/min up to 58 m/min

Drive power depending on belt speed and load ranging from 0.12 kW to 0.37 kW
(208-230/460V; 50/60Hz; IP54)
Max. total load of material 160 kg

Pulley

Number of teeth per pulley = 30
Pitch circle diameter = 47.75 mm

Belt Type

Standard application, cleated for incline transport, accumulation, etc.

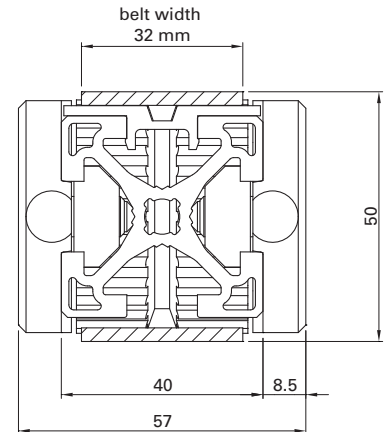

Side Guides for Timing Belt Conveyors see page 46

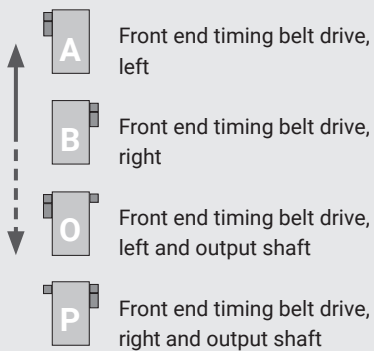
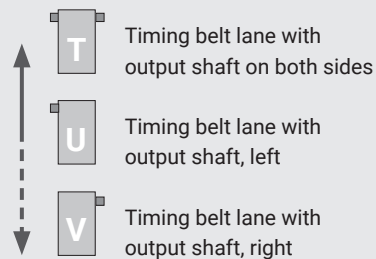
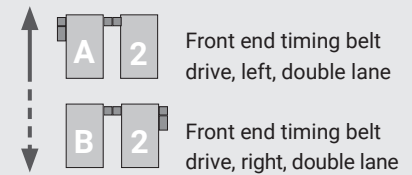
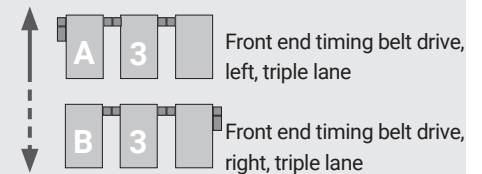
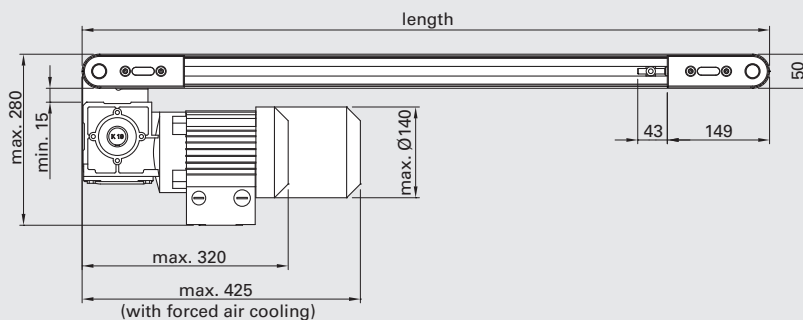
Drive Option¹**Front End Timing Belt Drive****Timing Belt Lane Without Motor****Front End Timing Belt Drive, Double Lane****Front End Timing Belt Drive, Triple Lane****Front End Timing Belt Drive**

Front End Timing Belt Drive

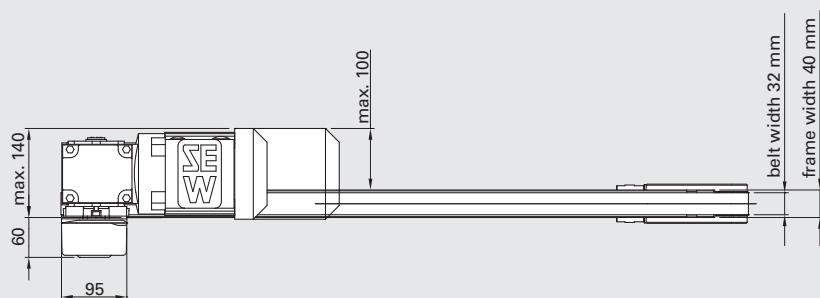

O/P

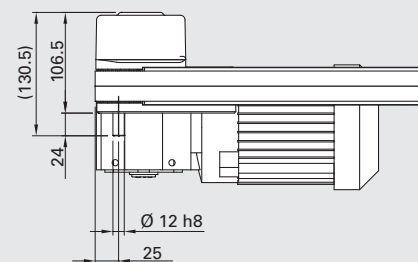

Front End Timing Belt Drive, Double Lane

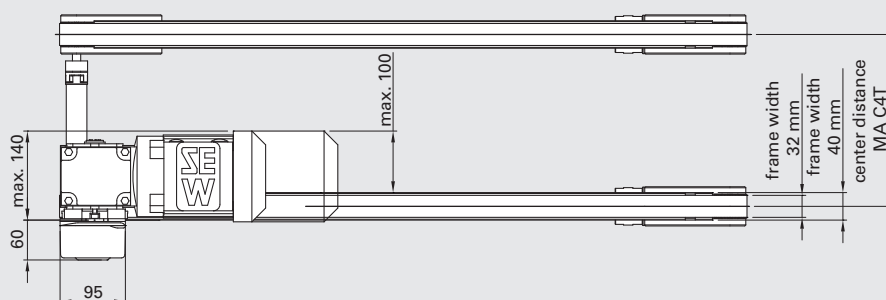

U/V

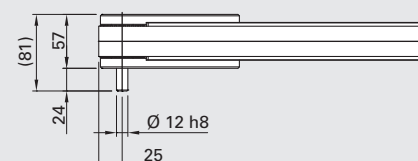

Front End Timing Belt Drive, Triple Lane

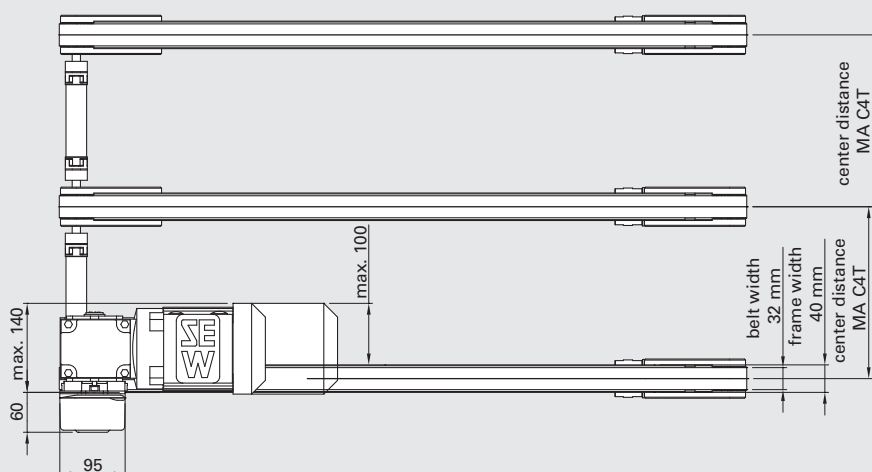

T

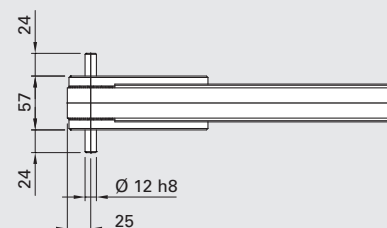

Length And Frame Width

Description	Min. length	Max. length	MA1	MA2
Timing Belt Conveyor 40 Front end timing belt drive	400 mm	12000 mm		
Timing Belt Conveyor 40 Front end timing belt drive, double lane	400 mm	12000 mm	----	
Timing Belt Conveyor 40 Front end timing belt drive, triple lane	400 mm	12000 mm	----	----
Timing Belt Conveyor 40 Timing belt lane without motor	400 mm	12000 mm		

Order Placement

Please use our Belt Conveyor configuration tool or our request form at www.robotunits.com

1) Standard direction is pulling. The running direction of all drives can be changed by reversing the polarity of the motor.
Drawing dimensions in mm

**Application**

Used for a wide variety of conveying applications

Technical Data

Speeds from 6 m/min up to 66 m/min

Drive power depending on belt speed and load ranging from
0.25 kW to 0.37 kW
(208-230/460V; 50/60Hz; IP54)
Max. total load of material 400 kg

Pulley

Number of teeth per pulley = 32
Pitch circle diameter = 101.85 mm

Belt Type

Standard application, cleated for
incline transport, accumulation, etc.

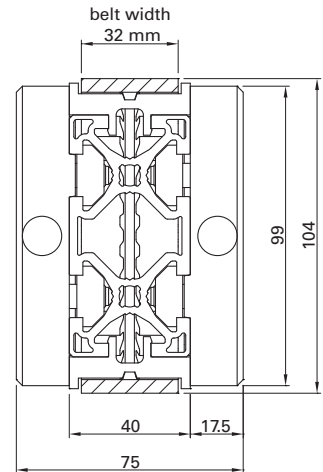

Side Guides for Timing Belt Conveyors
see page 46

Drive Option¹**Front End Timing Belt Drive, Fmax 4000 N**

- A** Front end timing belt drive, left
- B** Front end timing belt drive, right
- O** Front end timing belt drive, left and output shaft
- P** Front end timing belt drive, right and output shaft

Front End Direct Drive, Fmax 6000 N

- E** Front end direct drive left
- F** Front end direct drive, right
- R** Front end direct drive, left and output shaft
- S** Front end direct drive, right and output shaft

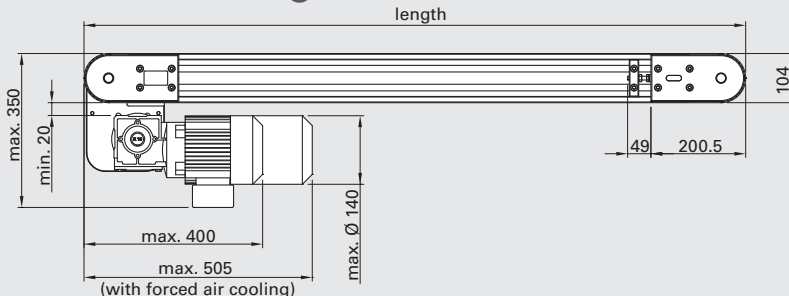
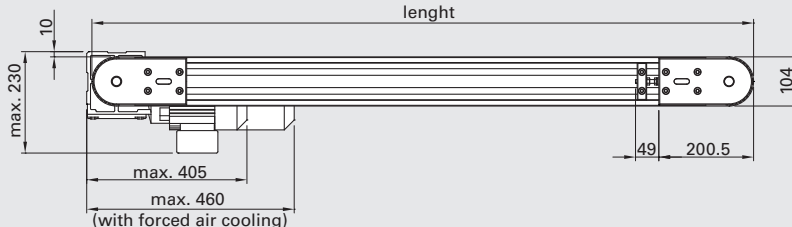
Front end timing belt drive**Front end direct drive****Front End Drive, Double Lane**

- A 2** Front end timing belt drive, left, double lane
- B 2** Front end timing belt drive, right, double lane
- E 2** Front end direct drive, left, double lane
- F 2** Front end direct drive, right, double lane

Front End Drive, Triple Lane

- A 3** Front end timing belt drive, left, triple lane
- B 3** Front end timing belt drive, right, triple lane
- E 3** Front end direct drive left, triple lane
- F 3** Front end direct drive right, triple lane

Timing Belt Lane Without Motor

- T** Timing belt lane with output shaft on both sides
- U** Timing belt lane with output shaft, left
- V** Timing belt lane with output shaft, right

Timing Belt Lane Without Motor, Adjustable

- W** Timing belt lane with splined shaft hub

Front End Timing Belt Drive, Double-, Triple Lane

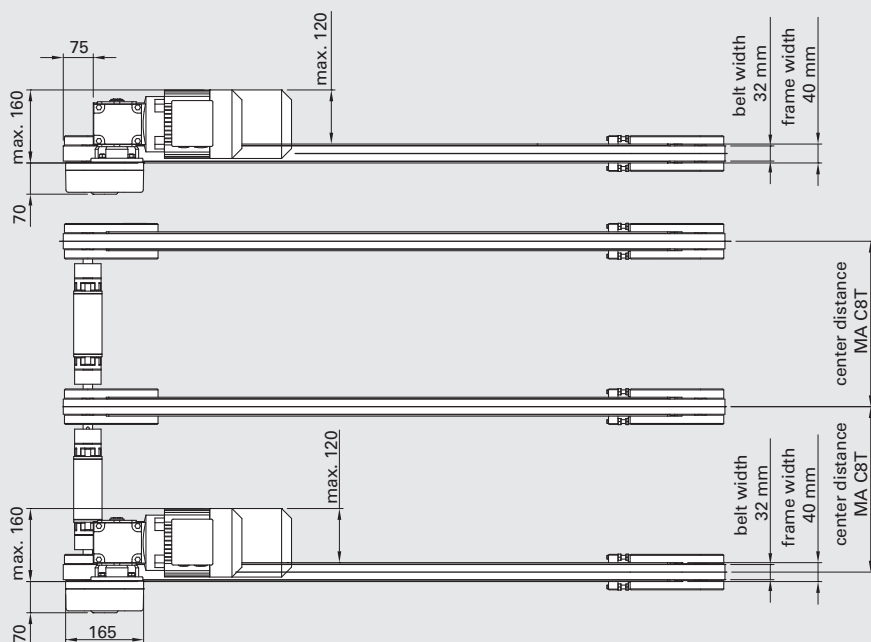

O/P

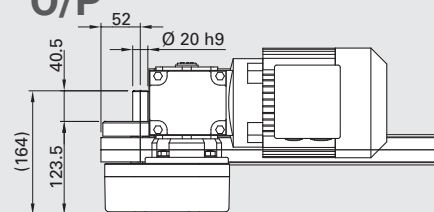

U/V

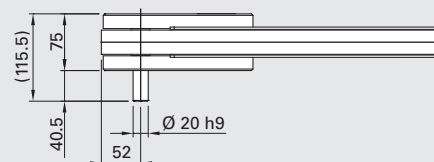

T

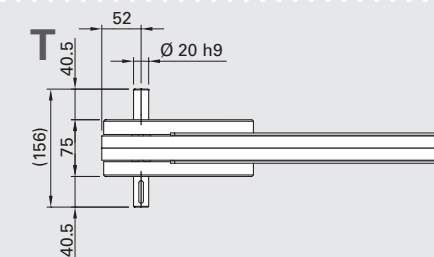

Front End Direct Drive, Double-, Triple Lane

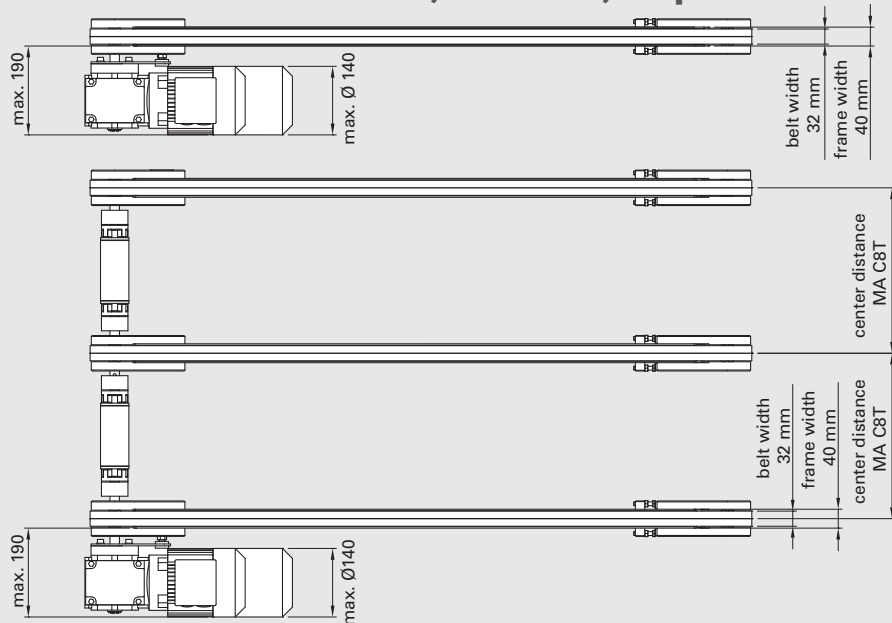

R/S

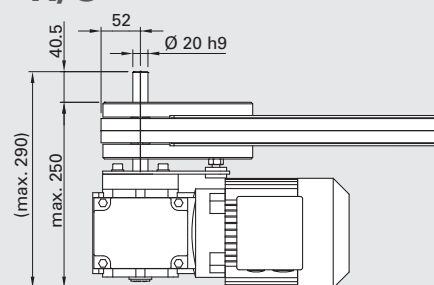

W, adjustable



Length And Frame Width

Description	Min. length	Max. length	MA1	MA2
Timing Belt Conveyor 80 Front end timing belt drive	550 mm	12000 mm		
Timing Belt Conveyor 80 Front end timing belt drive, double lane	550 mm	12000 mm	----	
Timing Belt Conveyor 80 Front end timing belt drive, triple lane	550 mm	12000 mm	----	----
Timing Belt Conveyor 80 Front end direct drive	550 mm	12000 mm		
Timing Belt Conveyor 80 Front end direct drive, double lane	550 mm	12000 mm	----	
Timing Belt Conveyor 80 Front end direct drive, triple lane	550 mm	12000 mm	----	----
Timing Belt Conveyor 80 Timing belt lane without motor	550 mm	12000 mm		

Order Placement

Please use our Belt Conveyor configuration tool or our request form at www.robotunits.com

1) Standard direction is pulling. The running direction of all drives can be changed by reversing the polarity of the motor.

C4G

Stand for C4T

**Application**

Stand for Timing Belt Conveyor 40

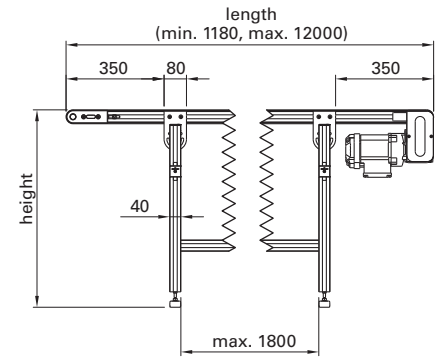
Technical DataMaterial: clear anodized aluminum;
galvanized GD-Zn; galvanized steel;
rubber**Scope of Delivery**Stand segment fully assembled and
attached to belt conveyor if applicable

Stand Types: Single Lane

Stand Types: Double Lanes

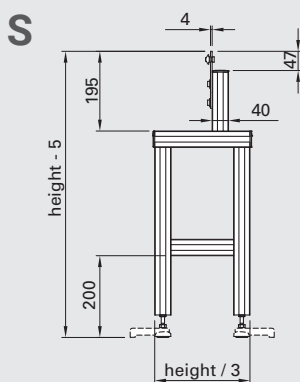
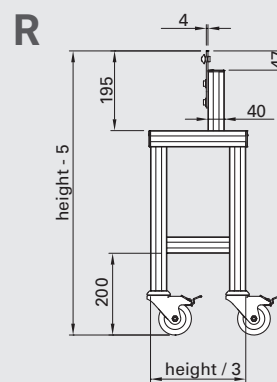
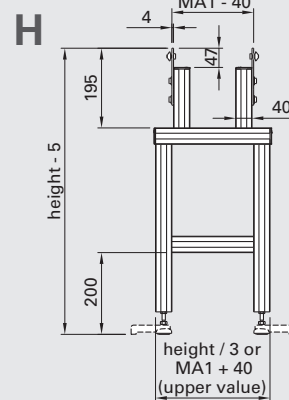
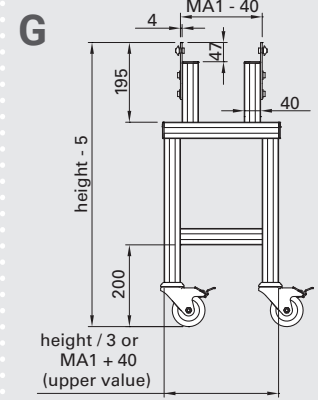
Leveling bases BAS 4008¹
Height adjustment ± 20 mmSwivel castors with brake
CAS 3080Leveling bases BAS 4008¹
Height adjustment ± 20 mmSwivel castors with brake CAS
3080

Stand Types: Triple Lane

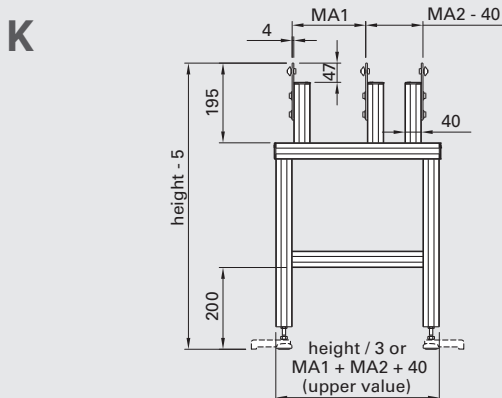
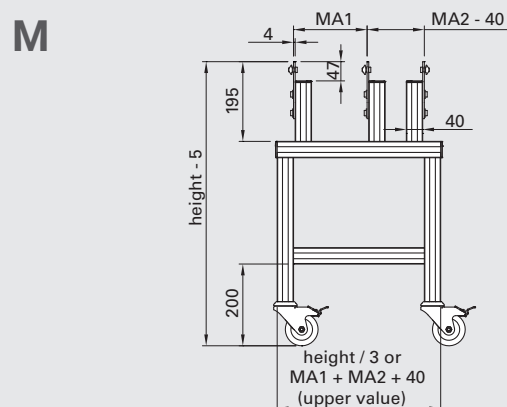
Leveling bases BAS 4008¹
Height adjustment ± 20 mmSwivel castors with brake
CAS 3080

Order Code

Description	Order Code ²				
	Length	Type	Height	MA1	MA2
Stand for C4T	---	_ NN	---	---	---

1) Optionally with Floor Mounting Plate BAP 4500

2) Please complete the order code by adding the corresponding parameters for order processing.

Drawing dimensions in mm

C8G

Stand for C8T



Application

Stand for Timing Belt Conveyor 80

Technical Data

Material: clear anodized aluminum; galvanized GD-Zn; galvanized steel; rubber

Scope of Delivery

Stand segment fully assembled and attached to belt conveyor if applicable

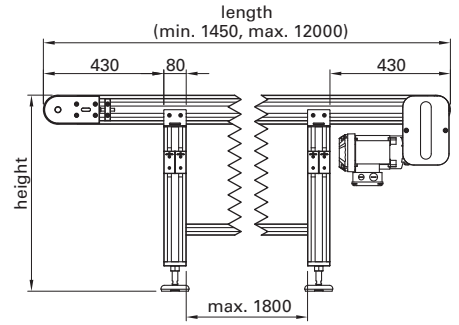

Stand Types: Single Lane

Stand Types: Double Lanes

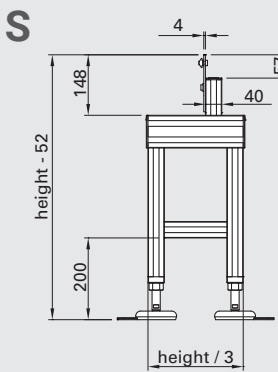

Leveling bases BAS 1120
Height adjustment ± 30 mm

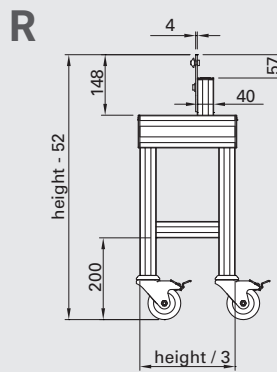

Swivel castors with brake CAS 3080

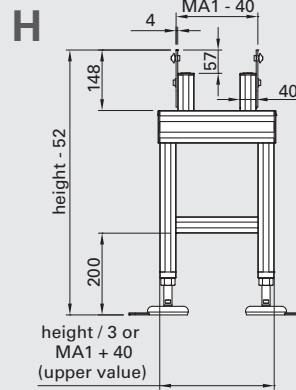

Leveling bases BAS 1120
Height adjustment ± 30 mm

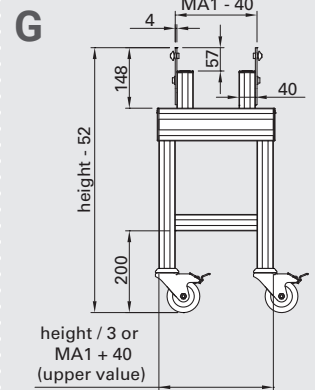

Swivel castors with brake CAS 3080

Stand Types: Triple Lane

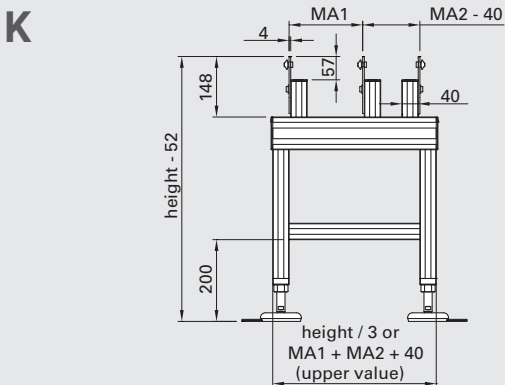

Leveling bases BAS 1120
Height adjustment ± 30 mm

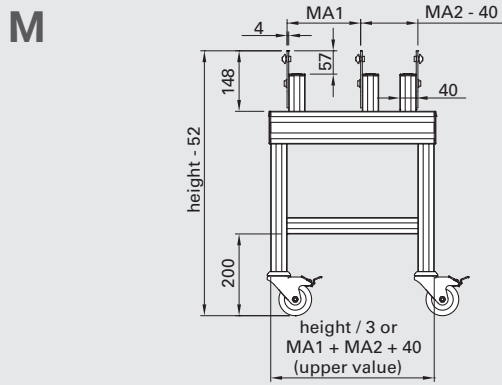

Swivel castors with brake CAS 3080

Order Code

Description	Order Code ¹				
	Length	Type	Height	MA1	MA2
Stand for C8T	C8G	---	- NN	---	---

1) Please complete the order code by adding the corresponding parameters for order processing.

Drawing dimensions in mm

Powered Roller Conveyor Straight



Powered Roller Conveyor Merge



Powered Roller Conveyor Curved

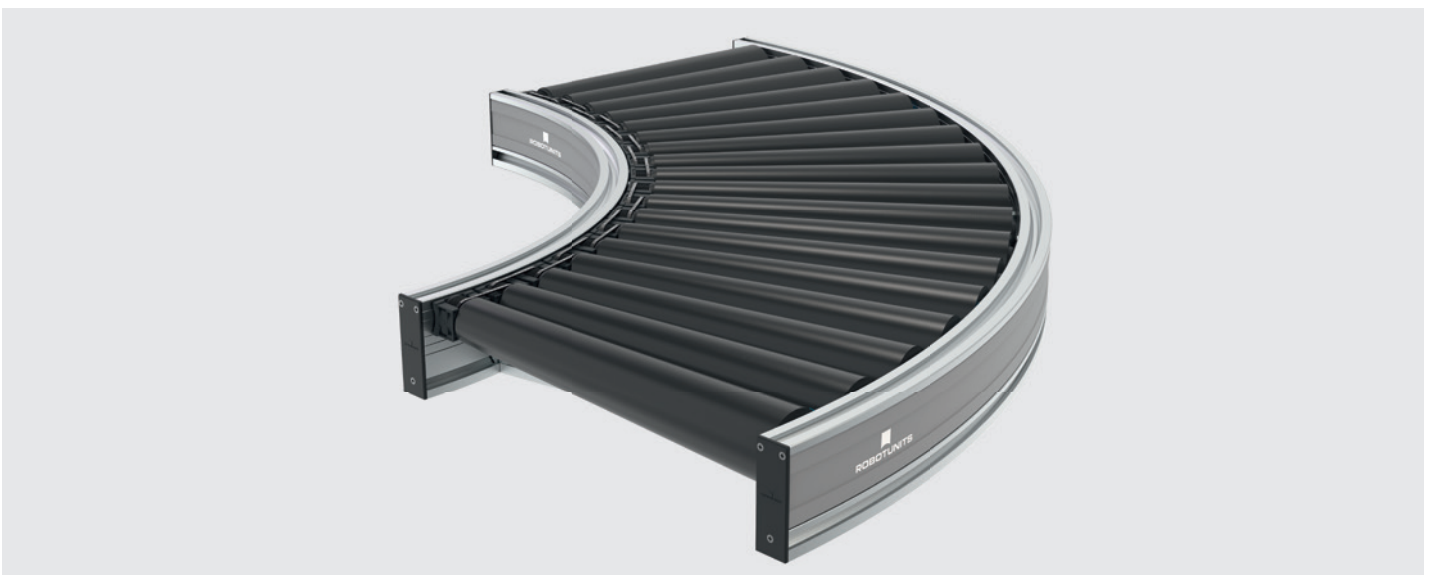

Transfer Unit 90°

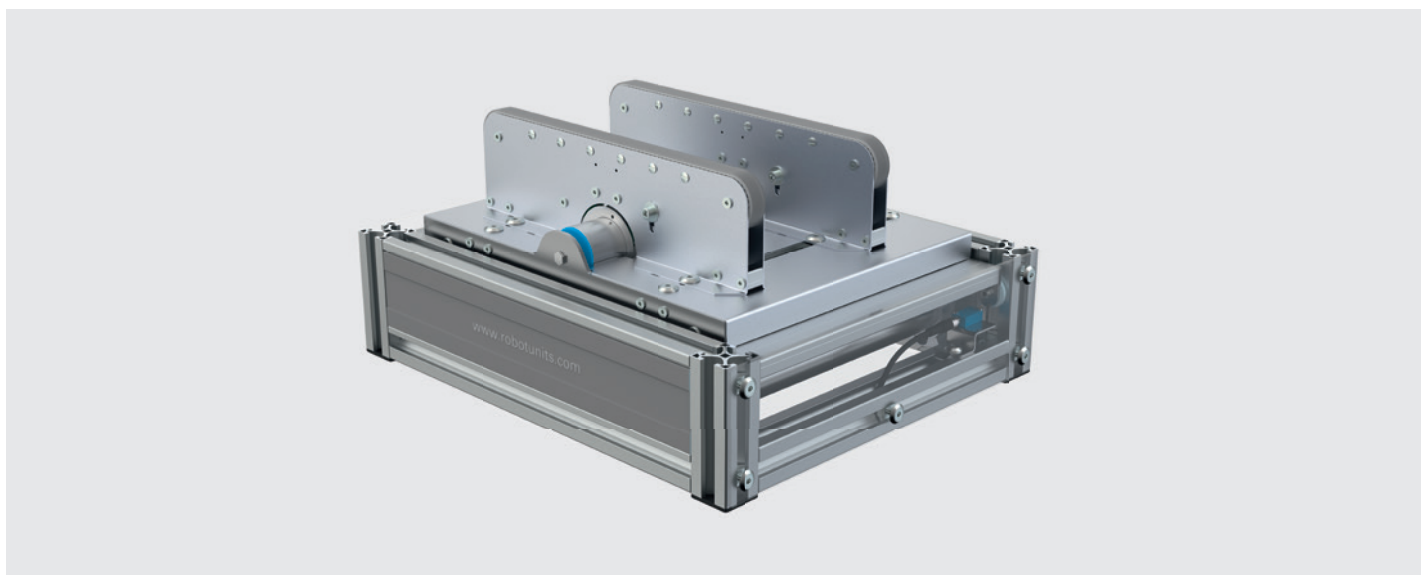











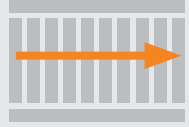

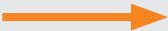
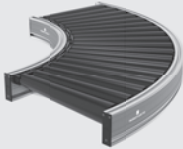

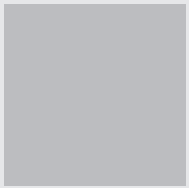



Turntable

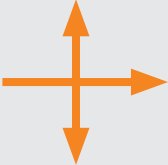
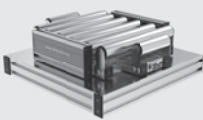

Lift Station

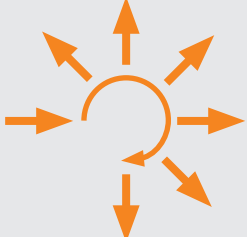

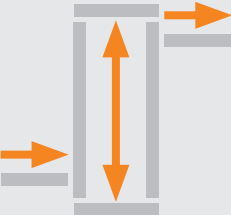
Powered Roller Conveyor Modules

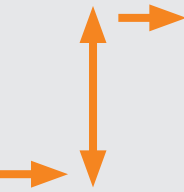
Module	Material alignment Available range Transfer	Space requirement	Output (cycles/h)	Applications
	 <p>0°</p>		 <p>max. 2000</p>	
	 <p>45° / 90°</p>		 <p>max. 2000</p>	
	 <p>0° / ±90°</p>		 <p>max. 1500</p>	
	 <p>0° - 270°</p>		 <p>max. 350</p>	
	 <p>0°</p>		 <p>max. 350</p>	

Zero Pressure Accumulation

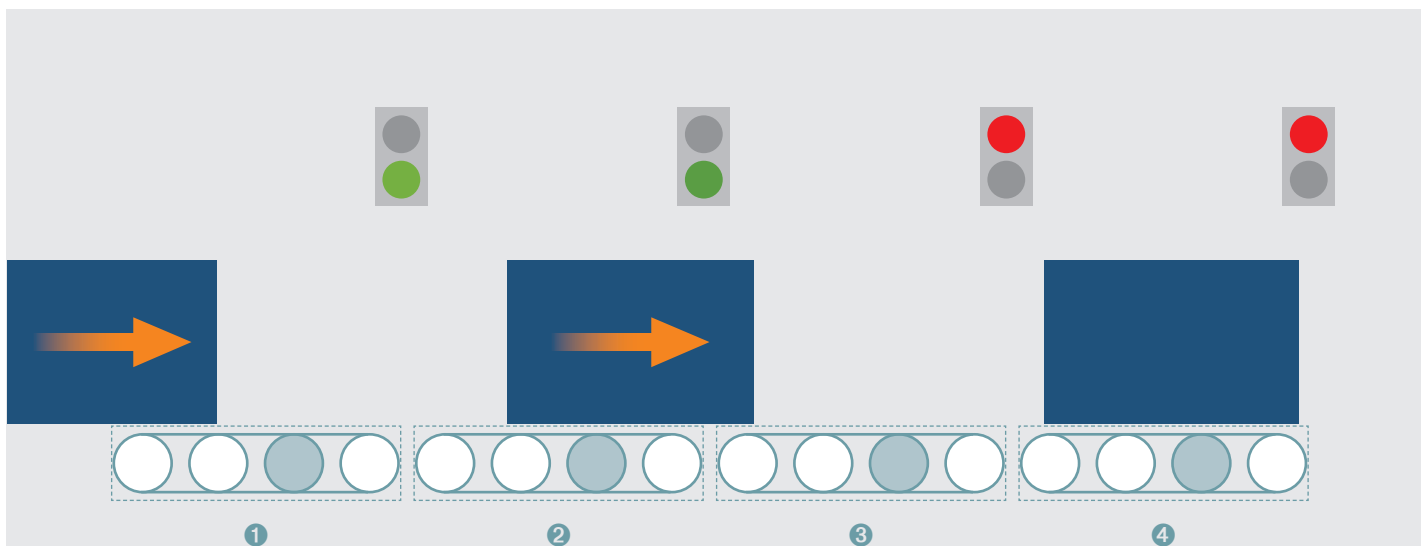

The roller conveyor with zero pressure accumulation logic (ZPA) is divided into individual zones. The different zones are interconnected and communicate with each other. If a transported product is running towards an occupied zone ④, the product remains in the previous free zone ③. When the occupied zones become free ④, upstream zones follow automatically ③.

Advantages

- + "Plug and Play" solution with decentralized controller = no primary control required (e.g. PLC)
- + Only the required rollers turn = energy efficient
- + Zero pressure (no-contact) conveying

Drive Technology

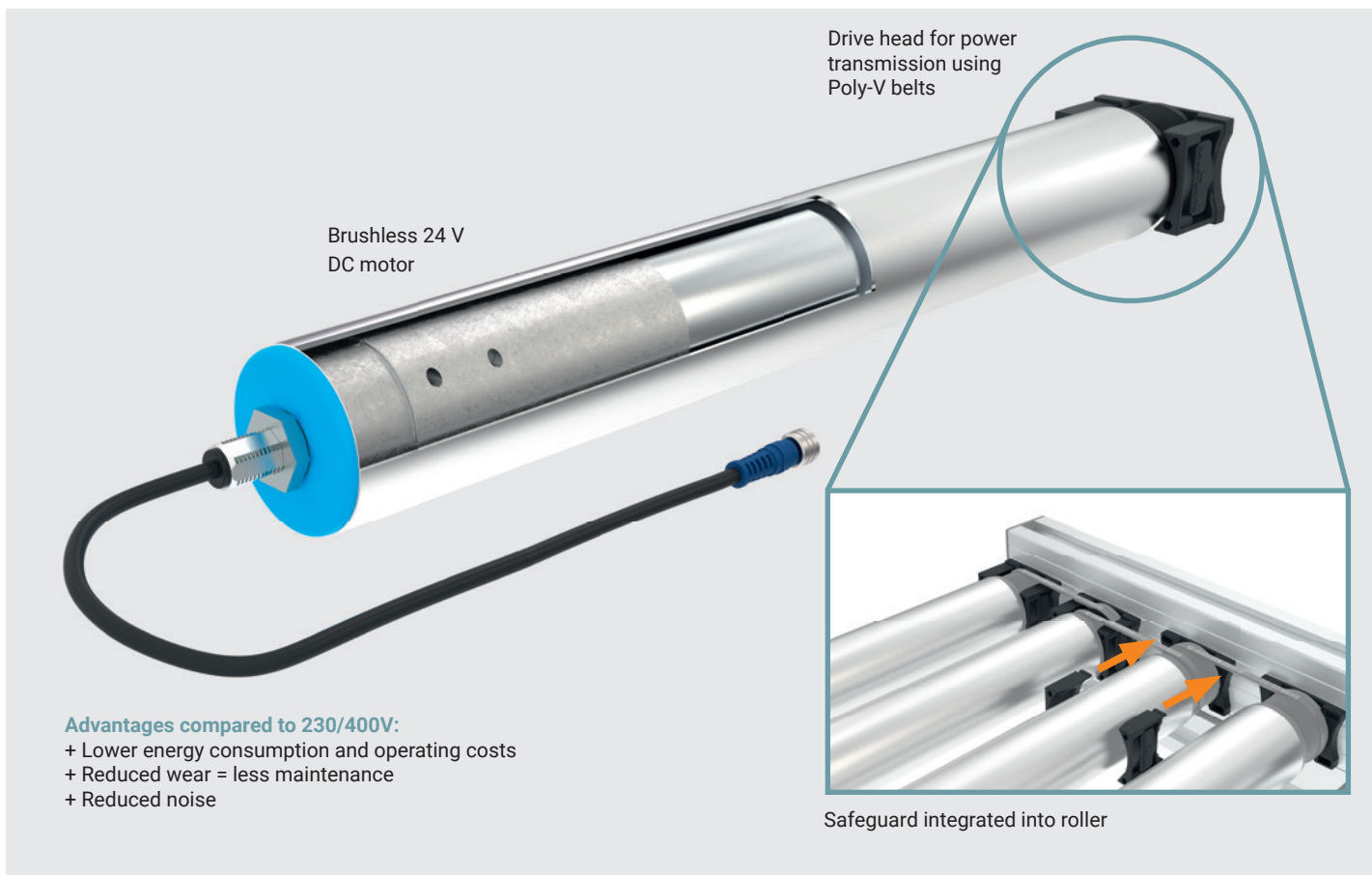

Advantages compared to 230/400V:

- + Lower energy consumption and operating costs
- + Reduced wear = less maintenance
- + Reduced noise



Side Guides for Powered Roller Conveyors
see page 47

Supported control protocols:



EtherNet/IP EtherCAT

Application

Zero pressure accumulation of products in various sizes.

Technical Data

Brushless 24 V DC motor
Speed Code / Speed:
15 = 2 to 20 m/min (Alternative)
20 = 10 to 28 m/min (Standard)
35 = 15 to 50 m/min (Alternative)
Temperature range: from +2°C to +40°C
Max. Continuous current per motorized roller: 2.5 A
Ø Continuous current per motor roller: 1.5 A
Conveyor rollers driven by Poly-V belts
Roller material: galvanized steel
Belt material: Chloroprene with PA tension members
Frame material: clear anodized aluminum
Max. product load: 50 kg

Control Unit:

Completely pre-installed incl. sensors

Configuration:

Zero pressure accumulation control logic (not with EtherCAT)

Option without side guides

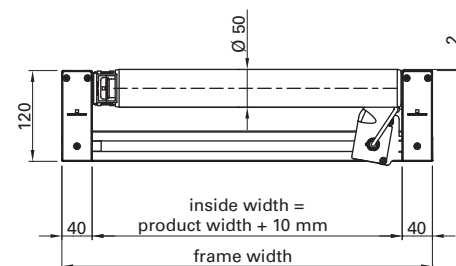

Option with side guides

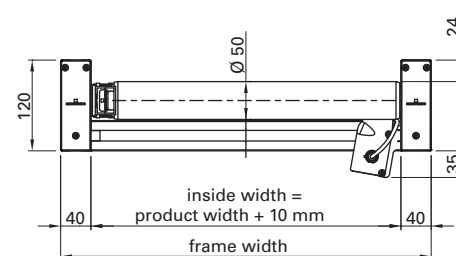

Dimensions

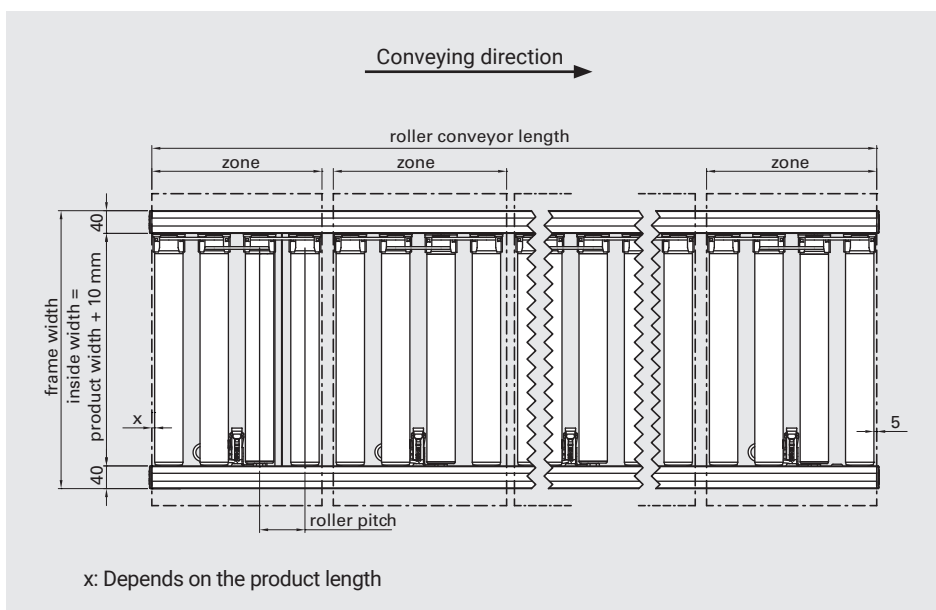

Variant

Angled Powered Roller Conveyor

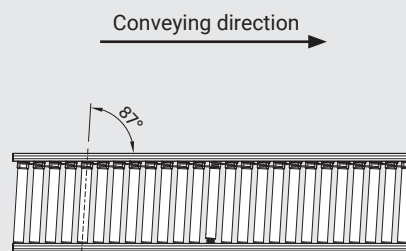

Standard Dimensions

Description	Box (LxW)	Inside width	Frame width	Roller pitch	Standard length up to
Powered Roller Conveyor Straight	400 x 300 mm	310 mm	390 mm	105 mm	6000 mm
Powered Roller Conveyor Straight	300 x 400 mm	410 mm	490 mm	80 mm	6000 mm
Powered Roller Conveyor Straight	600 x 400 mm	410 mm	490 mm	160 mm	6000 mm
Powered Roller Conveyor Straight	600 x 400 mm	610 mm	690 mm	105 mm	6000 mm

Special widths (min. inside width 310 mm, max. inside width 1210 mm), special lengths and special roller pitch are available on request.
Guide line for roller pitch calculation = product length in conveying direction / 3.75

R5M

Powered Roller Conveyor Merge



Side Guides for Powered Roller Conveyors see page 47

Supported control protocols:



Application

Zero Pressure accumulation conveying and merging into an existing conveyor line

Technical Data

Brushless 24 V DC motor
 Speed Code / Speed:
 15 = 2 to 20 m/min (Alternative)
 20 = 10 to 28 m/min (Standard)
 35 = 15 to 50 m/min (Alternative)
 Temperature range: from +2°C to +40°C
 Max. Continuous current per motorized roller: 2.5 A
 Ø Continuous current per motor roller: 1.5 A
 Conveyor rollers driven by Poly-V belts
 Roller material: galvanized steel
 Belt material: Chloroprene with PA tension members
 Frame material: clear anodized aluminum
 Max. product load: 50 kg

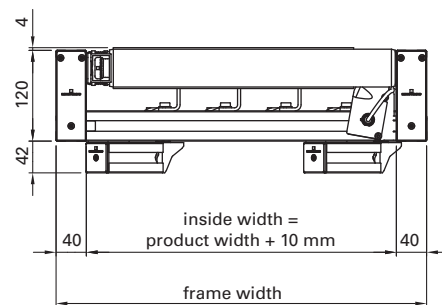

Control Unit:

Completely pre-installed incl. sensors and control cabinet

Configuration:

Zero pressure accumulation control logic with downstream roller conveyor (not with EtherCAT)

Dimensions

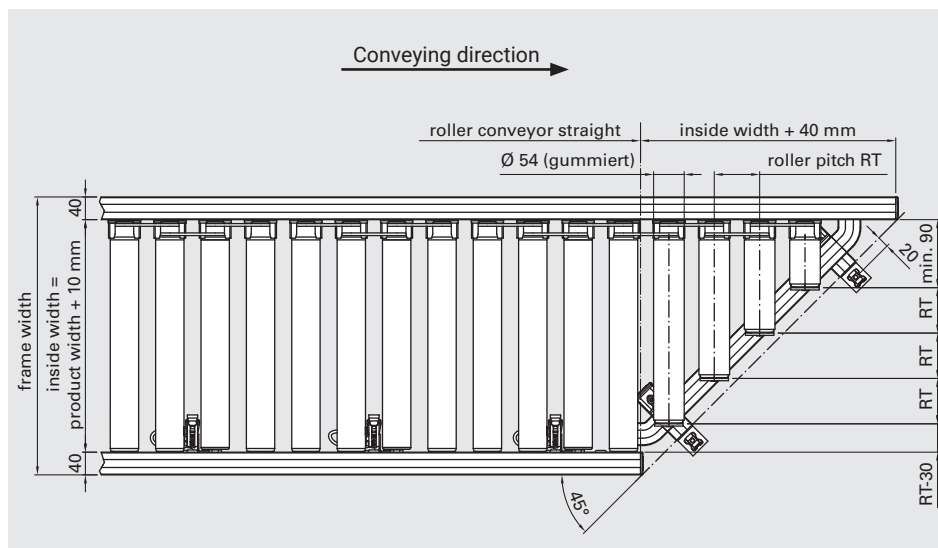

Layout

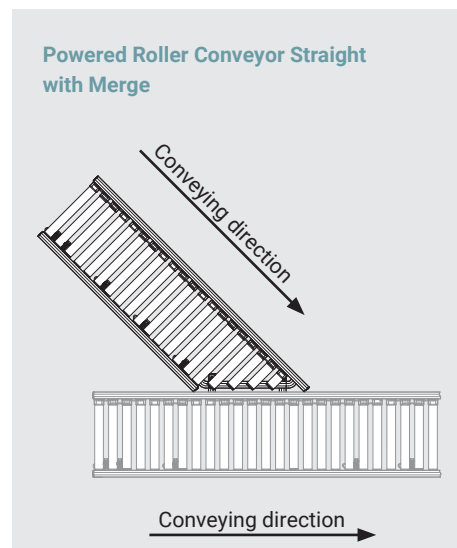

Standard Dimensions

Description	Box (LxB)	Inside width	Frame width	Roller pitch	Standard length up to
Powered Roller Conveyor Merge	400 x 300 mm	310 mm	390 mm	105 mm	6000 mm
Powered Roller Conveyor Merge	300 x 400 mm	410 mm	490 mm	80 mm	6000 mm
Powered Roller Conveyor Merge	600 x 400 mm	410 mm	490 mm	160 mm	6000 mm
Powered Roller Conveyor Merge	400 x 600 mm	610 mm	690 mm	105 mm	6000 mm

Special dimensions are available on request.

Drawing dimensions in mm

R5C

Powered Roller Conveyor Curved

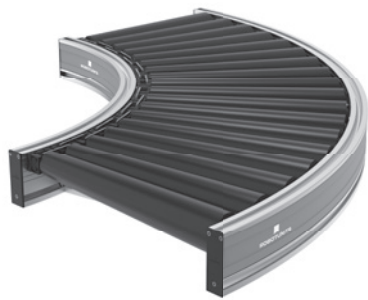

Side Guides for Powered Roller Conveyors
see page 47

Supported control protocols:



EtherNet/IP EtherCAT

Application

Zero pressure accumulation of products in various sizes.

Technical Data

Brushless 24 V DC motor

Speed Code / Speed:

15 = 2 to 20 m/min (Alternative)

20 = 10 to 28 m/min (Standard)

35 = 15 to 50 m/min (Alternative)

Temperature range: from +2°C to +40°C

Max. Continuous current per motorized roller: 2.5 A

Ø Continuous current per motor roller: 1.5 A

Conveyor rollers driven by Poly-V belts

Roller material: galvanized steel,
conical plastic attachments

Belt material: Chloroprene with PA
tension members

Frame material: clear anodized aluminum

Max. product load: 50 kg

Control Unit:

Completely pre-installed incl. sensors

Configuration:

Zero pressure accumulation control logic
(not with EtherCAT)

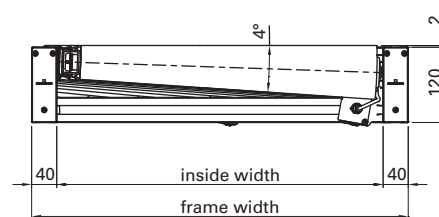

Dimensions

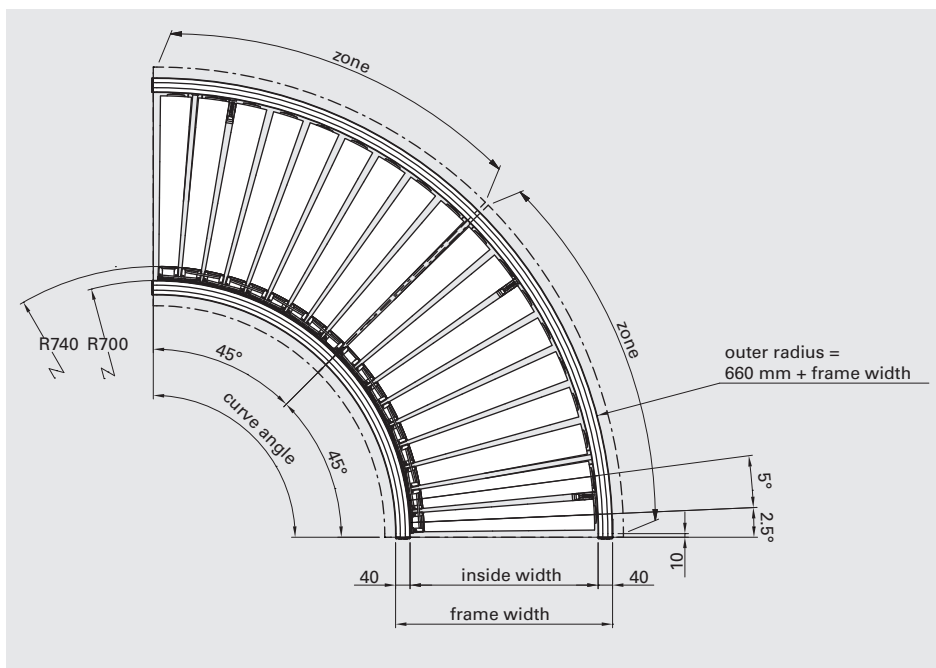

Standard Angles

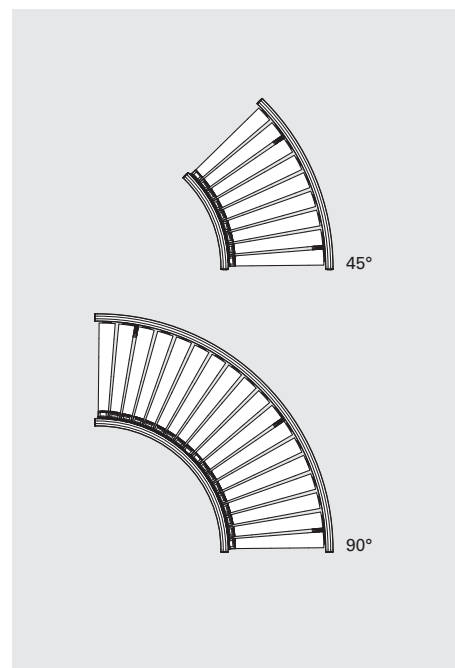

The inside width depends on the dimensions of the transported product. Inside width min. 310 mm, inside width max. 1040 mm
Special curve angles are available on request.

Request For Quote / Order

Please use our request form at www.robotunits.com.

Drawing dimensions in mm

R5T

Transfer Unit 90°

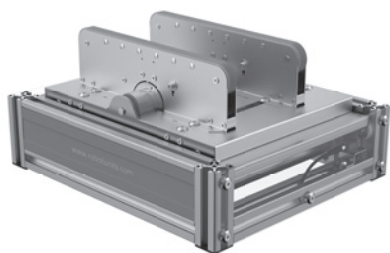

Side Guides for Powered Roller Conveyors
see page 47

Supported control protocols:



EtherNet/IP EtherCAT

Application

90 degree transfer of products in various sizes. It can be integrated into any zone of a Powered Roller Conveyor Straight.

Technical Data

Motor: 24 V DC motor for lift motion with a temperature range from +2°C to +40°C
Max. Continuous current per motorized roller: 3.5 A
Roller material: galvanized steel
Timing belt material: PU
Time for Stroke: 0.5 s
Max. product load: 50 kg

Control unit:

Completely pre-installed incl. sensors

Configuration:

Zero pressure accumulation control logic with downstream roller conveyor (not with EtherCAT)

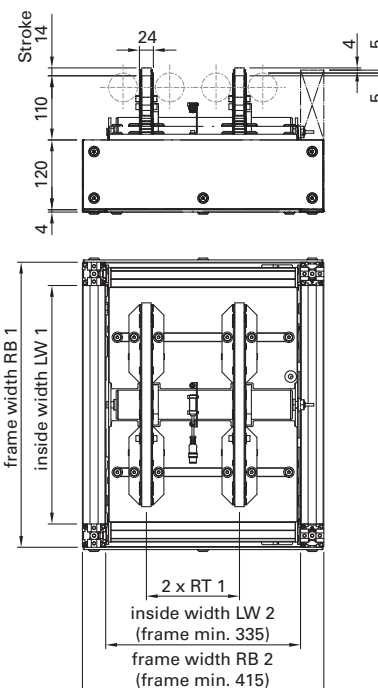

Dimensions

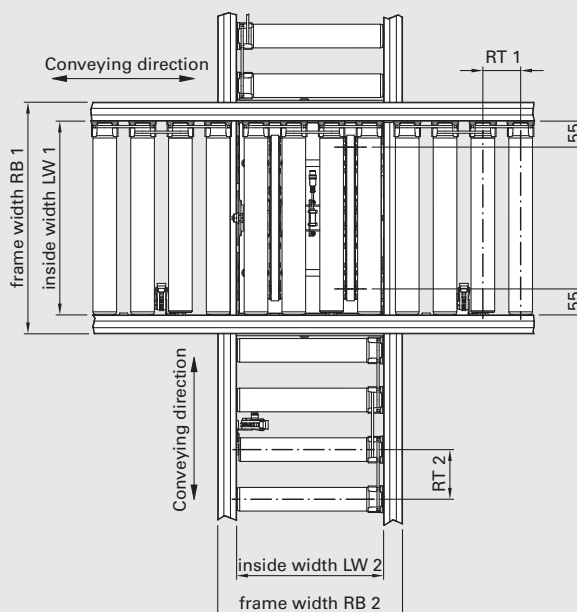

Standard Dimensions

Description	Box (LxB)	Powered Roller Conveyor with Transfer Unit 90°			In-feed or out-feed Powered Roller Conveyor		
		LW 1	RB 1	RT 1	LW 2	RB 2	RT 2
Transfer Unit 90°	400 x 300 mm	310 mm	390 mm	105 mm	410 mm	490 mm	80 mm
Transfer Unit 90°	300 x 400 mm	410 mm	490 mm	80 mm	310 mm	390 mm	105 mm
Transfer Unit 90°	600 x 400 mm	410 mm	490 mm	160 mm	610 mm	690 mm	105 mm
Transfer Unit 90°	400 x 600 mm	610 mm	690 mm	105 mm	410 mm	490 mm	160 mm

Special dimensions are available on request.

Drawing dimensions in mm



Side Guides for Powered Roller Conveyors
see page 47

Supported control protocols:



Application

Correctly positioned turning of products in various sizes

Technical Data

Brushless 24 V DC motor for lift and belt
Temperature range from +2°C to +40°C
Max. Continuous current per motorized roller: 2.5 A
Turning range: 0° – 270°
Cycle time for 90°: 2.5 s
Max. product load: 50 kg

Control unit:

Completely pre-installed incl. sensors

Configuration:

Zero pressure accumulation control logic with downstream roller conveyor (not with EtherCAT)

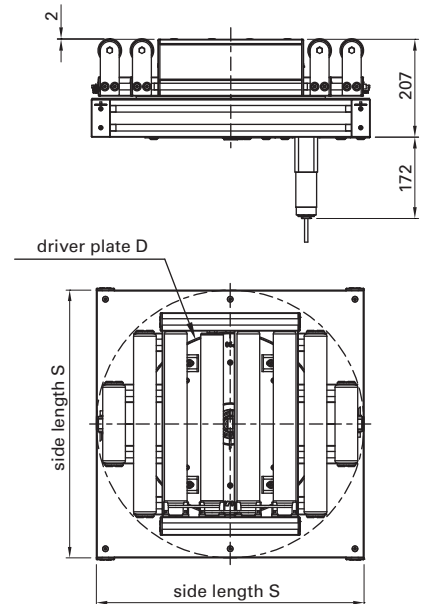

Dimensions

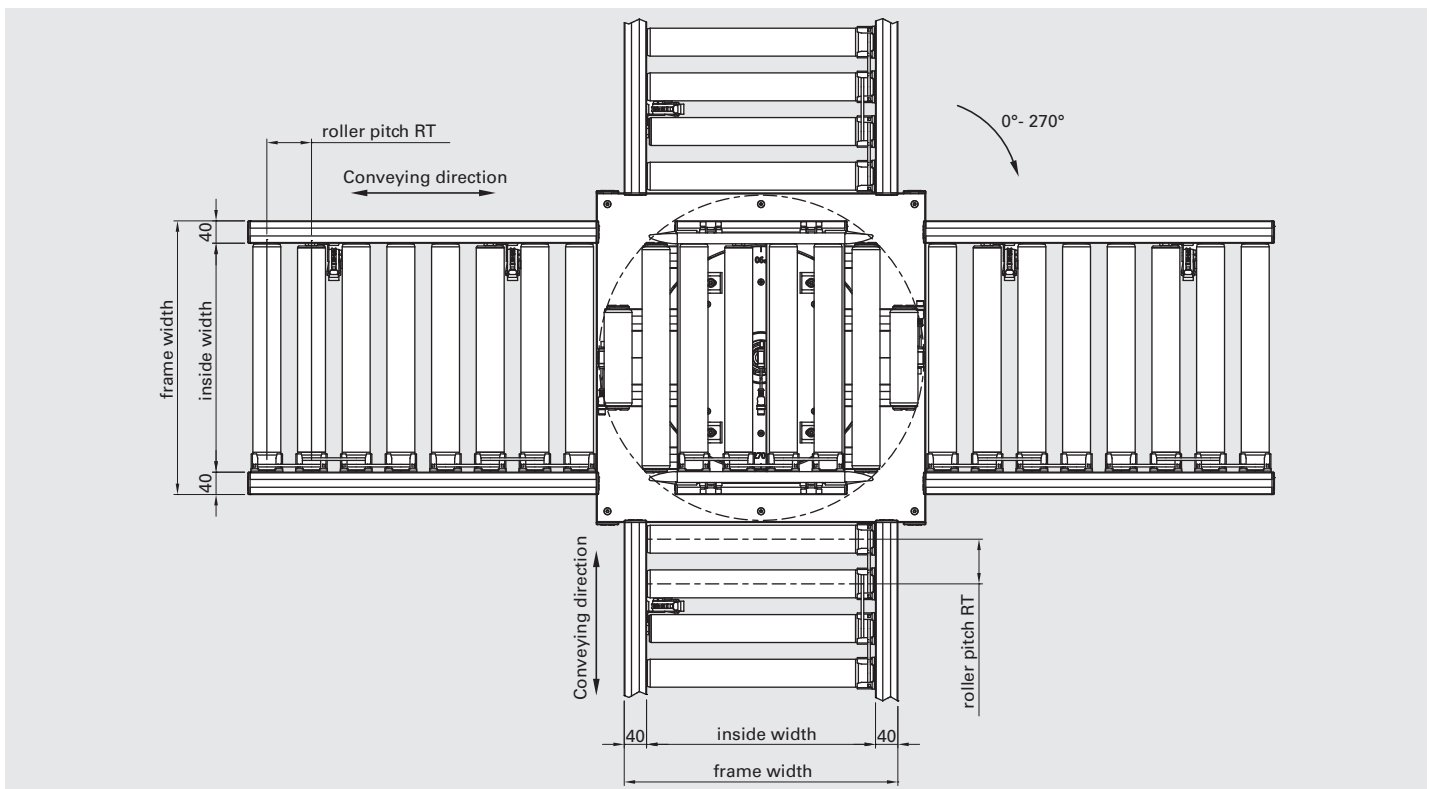

Standard Dimensions

Description	Box (LxW)	Roller Conveyor on the Turntable			Turntable	
		Inside width	Frame width	Roller pitch	Side length S	Carriage plate D
Turntable with Powered Roller Conveyor	400 x 300 mm	310 mm	390 mm	105 mm	590 mm	Ø 400 mm
Turntable with Powered Roller Conveyor	300 x 400 mm	410 mm	490 mm	80 mm	590 mm	Ø 400 mm
Turntable with Powered Roller Conveyor	600 x 400 mm	410 mm	490 mm	160 mm	790 mm	Ø 630 mm
Turntable with Powered Roller Conveyor	400 x 600 mm	610 mm	690 mm	105 mm	790 mm	Ø 630 mm

Special dimensions are available on request.

Drawing dimensions in mm

R5L

Lift Station With Powered Roller Conveyor



Application

Zero pressure accumulation conveying of products in different sizes over 2 levels

Technical Data

Lift station with three-phase geared motor 400V
 Speed max. 1 m/s
 Acceleration max. 0,7 m/s²
 Roller conveyor with brushless 24V DC motor
 Speeds from 10 to 28 m/min
 Temperature range from + 2°C bis + 40°C
 Frame material: clear anodized aluminum
 Enclosure with polycarbonate panels, optional with safety tunnel and door

Control Unit:

Completely pre-installed incl. sensors and control cabinet

Configuration:

Zero pressure accumulation control logic with downstream roller conveyor (not with EtherCAT)

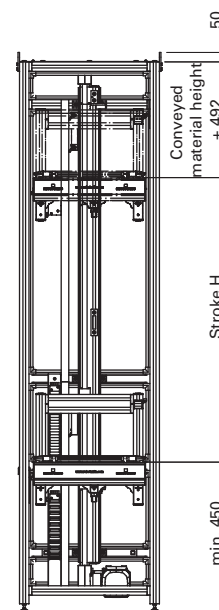

Side Guides for Powered Roller Conveyors see page 47

Supported control protocols:



Dimensions

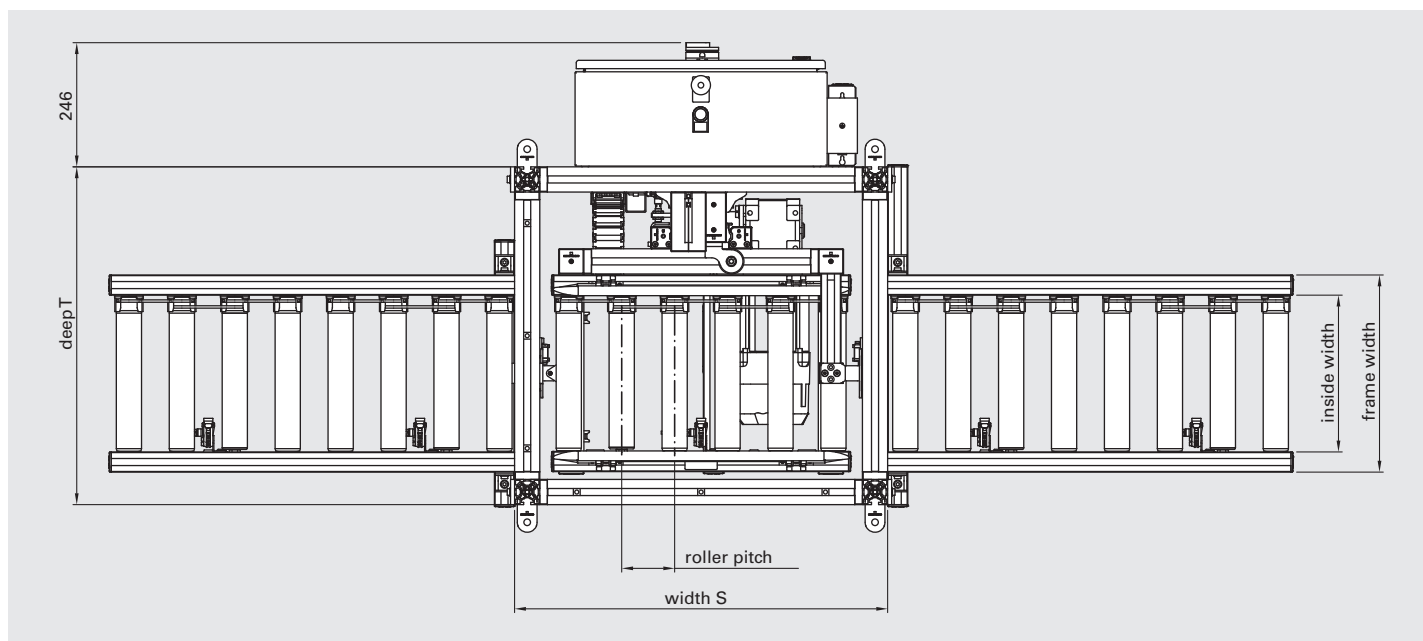

Standard Dimensions

Description	Box (LxW)	Roller Conveyor with Lift Station			Lift Station	
		Inside width	Frame width	Roller pitch	Base area (SxT)	Max. Hub h
Lift Station with Powered Roller Conveyor	400 x 300 mm	310 mm	390 mm	105 mm	740 x 670 mm	5000 mm
Lift Station with Powered Roller Conveyor	300 x 400 mm	410 mm	490 mm	80 mm	755 x 770 mm	5000 mm
Lift Station with Powered Roller Conveyor	600 x 400 mm	410 mm	490 mm	160 mm	1015 x 770 mm	5000 mm
Lift Station with Powered Roller Conveyor	400 x 600 mm	610 mm	690 mm	105 mm	740 x 970 mm	5000 mm

Special dimensions are available on request.

Drawing dimensions in mm

R5F

Stand for R5S



Application

Stand for Powered Roller Conveyor
Straight

Technical Data

Material: clear anodized aluminum,
galvanized GD-Zn, galvanized steel,
PA 6 or rubber

Scope of Delivery

Stand segment fully assembled

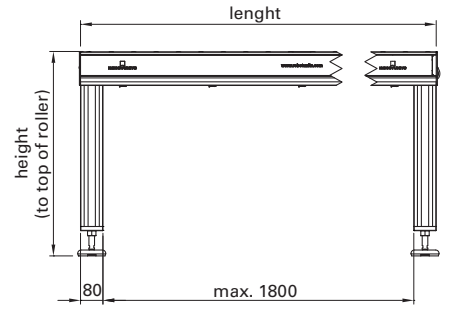

Standard Conveyor Stand

S

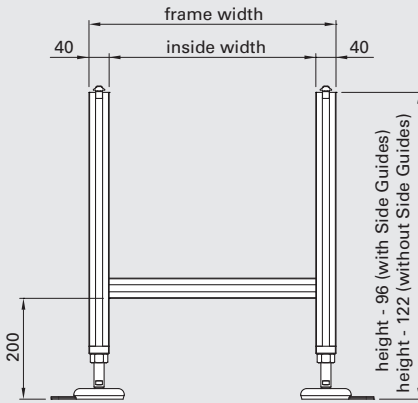

Leveling bases BAS 1120
Height adjustment ± 30 mm

R

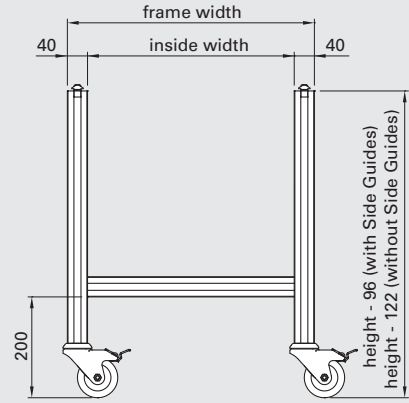

Swivel Castors with brake
CAS 3080

Order Code

Description	Order Code ¹		
	Frame width	Type	Height
Stand for R5S	R5F	---	_ NN

1) Please complete the order code by adding the corresponding parameters for order processing.

Drawing dimensions in mm

R5G

Stand for R5C



Application

Stand for Powered Roller Conveyor
Curved

Technical Data

Material: clear anodized aluminum, galvanized GD-Zn, galvanized steel, PA 6 or rubber

Scope of Delivery

Stand segment fully assembled

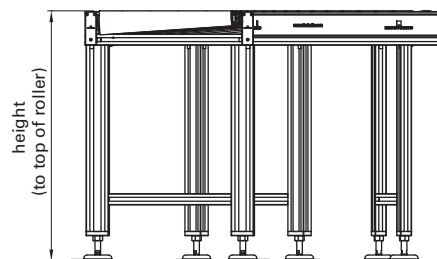

Standard Conveyor Stand

S

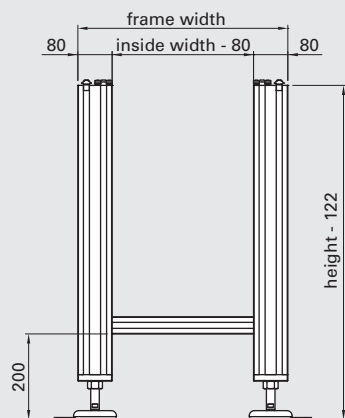

Leveling bases BAS 1120
Height adjustment ± 30 mm

R

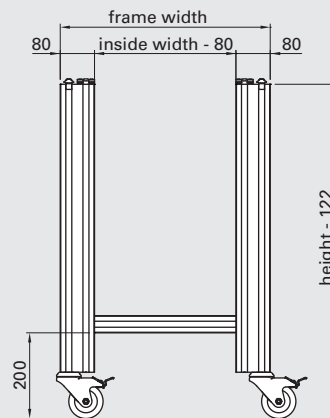

Swivel Castors with brake
CAS 3080

Order Code

Description	Order Code ¹		
	Frame width	Type	Height
Stand for R5C	R5G	_ NN	----

1) Please complete the order code by adding the corresponding parameters for order processing.
Drawing dimensions in mm

Side Guide System for Belt, Timing Belt and Modular Belt Conveyors

Belt Conveyor (integrated)

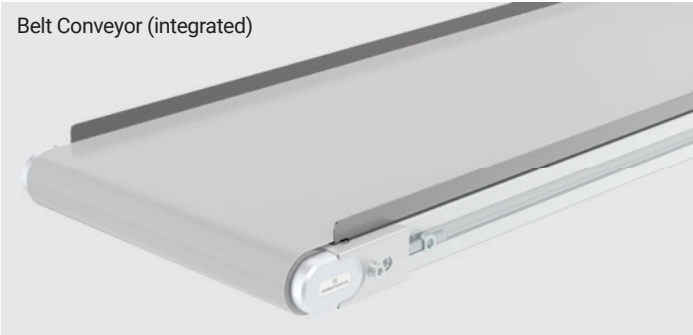

see catalog
page 16 (C4N)
page 18 (C5N)
page 20 (C8N)

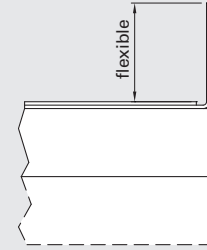

Belt Conveyor



Guide range with
standard square
tube length:
150 mm
(special length
possible)

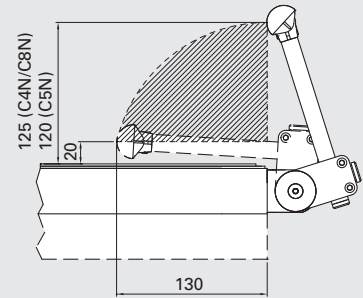

Modular Belt Conveyor

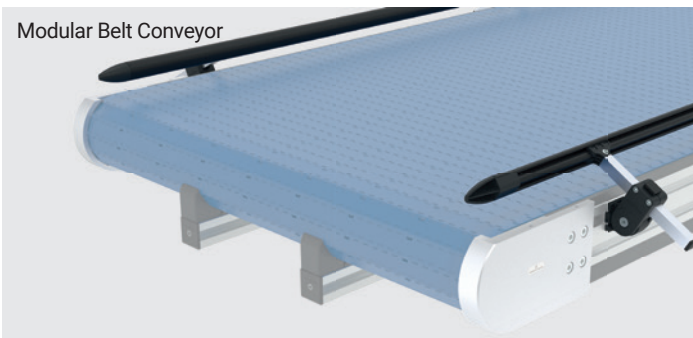

Guide range with
standard square
tube length:
150 mm
(special length
possible)

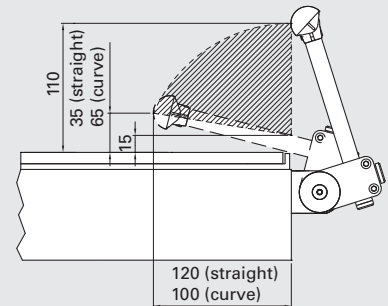

Timing Belt Conveyor



Guide range with
standard square
tube length:
150 mm
(special length
possible)

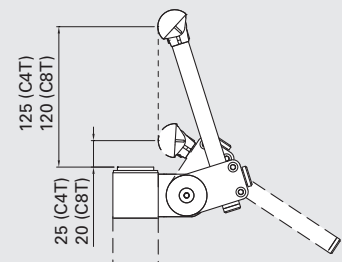

Construction

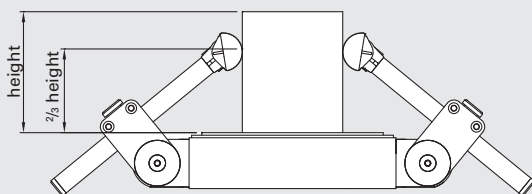

Recommended height for side guide



Adjustment range side guide

Side Guide System for Powered Roller Conveyors

Integrated (only with Powered Roller Conveyor Straight)



see catalog page 38

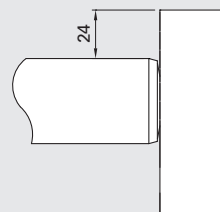

Rigid

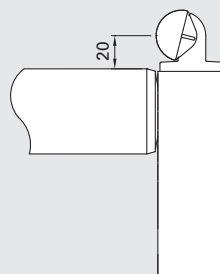

Flexible, with overhang



Guide range with standard square tube length: 150 mm (special length possible)

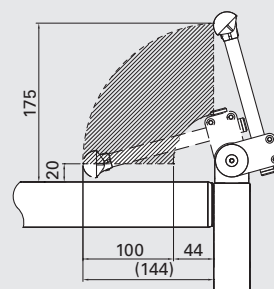

Flexible, without overhang



Guide range with standard square tube length: 30 mm (special length possible)

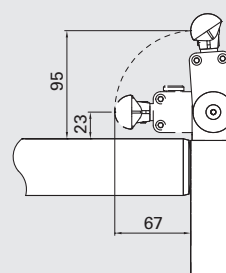

Assembly

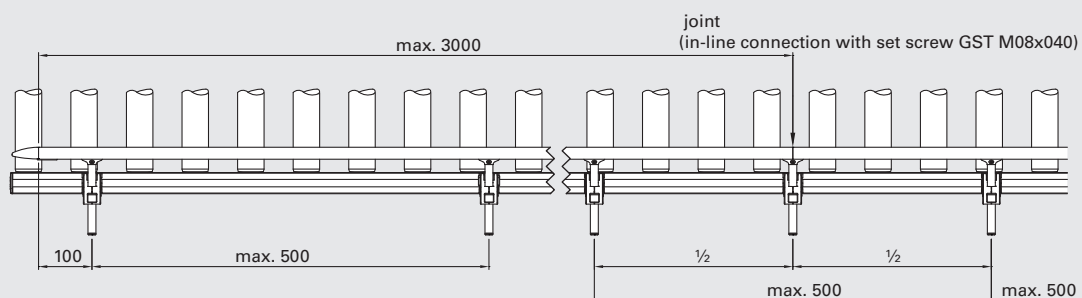

Divide side guide base or clip evenly.
Attention: Do not exceed maximum distances!

Application

For individual positioning of side guides

Technical Data

Material:

Basic part: PA6 black

Brackets: PA6 GF30 black

End cap: 18x18 PE-LLD

Hardware material: Galvanized steel

Scope of Delivery

- 1 Side Guide Basic Part
- 1 Side Guide Nut Holder
- 1 Side Guide Bracket Screw
- 2 Screw IBS M05x025
- 2 Hexagon nuts SKM M005
- 1 Screw IBS M08x030 EXNIKO
- 1 Washer SIS M08x13x0.8
- 1 Hexagon nut SKM M008
- 1 CAP 1818 cover cap

Tightening Torque

IBS M05x025 = 6 Nm

IBS M08x030 EXNIKO = 10 Nm

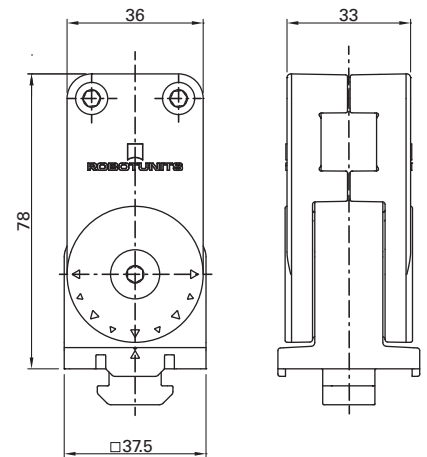
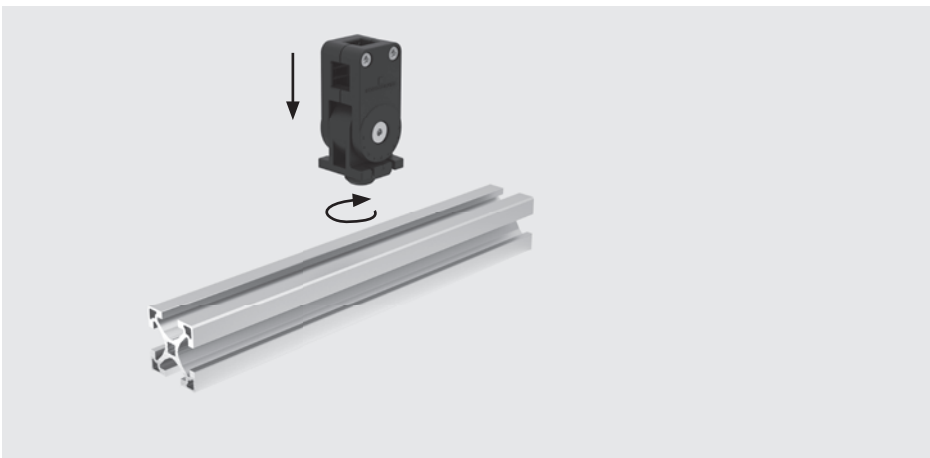
**Assembly****Order Code**

Description	Order Code	Weight
Side Guide Base	COP4561	0.095 kg

CO_900_

Side Guide Clamp With Rod



Application

For individual positioning of side guides

Technical Data

Material:

Clamping part: PA6.6 black

End cap: 15x15 PE-LLD

Square tube: Aluminium EN AW-6060-T66

Fixing material: Galvanized steel

Scope of Delivery

1 Side Guide Clamping Part

1 Screw IBS M05x014

1 Hexagon nut SKM M005

1 CAP 1515 cover cap

1 Square tube 15x15 length 150 mm or variable

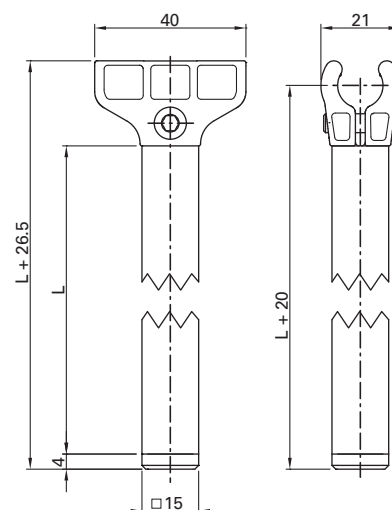

Order Code

Description	Order Code ¹	Weight
Side Guide Clamp with Rod, length 150 mm	COP9001	0.045 kg
Side Guide Clamp with Rod, cut to length	COL9000SNN	

1) Please complete the order by adding the corresponding parameters for order processing.

Drawing dimensions in mm

COP4570

Side Guide Clip

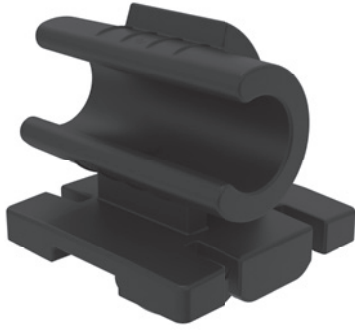
**Application**

To accommodate side guides

Technical Data

Material: PA6 black

Scope of Delivery

10 Side Guide Clips

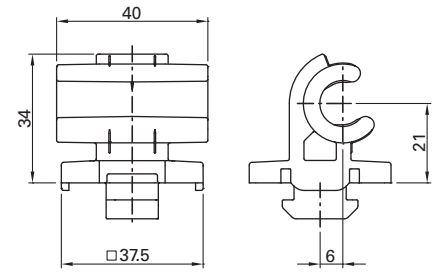

Assembly

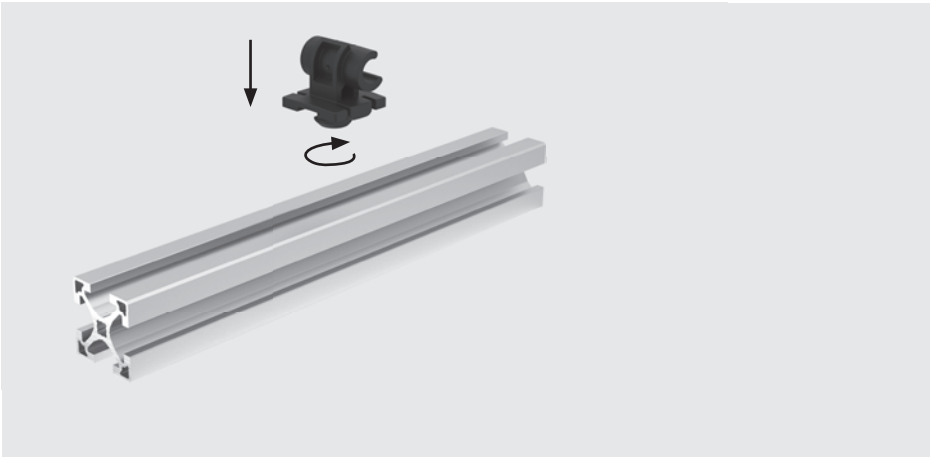

Order Code

Description	Order Code	Weight/Piece
Side Guide Clip, pack of 10 pcs.	COP4570	0.020 kg

COP4590

Side Guide End Piece

**Application**

To cover ends of Side Guides

Technical Data

Material: PP ESD black

Scope of Delivery

4 Side Guide End Pieces

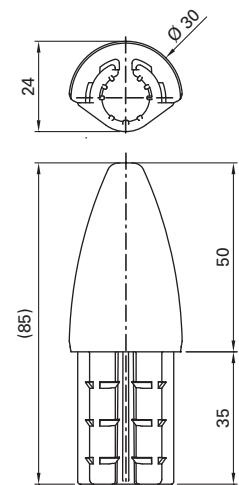

Order Code

Description	Order Code	Weight/Piece
Side Guide End Piece, pack of 4 pcs.	COP4590	0.010 kg

COL4590

Side Guide Plastic

**Application**

Side Guide for conveyors

Technical Data

Material: PVC-U black

Plastic profile is thermoformable by using a heat gun (softening point 80°C)

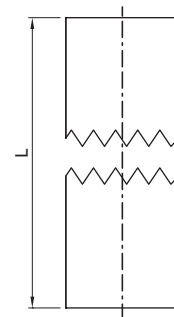
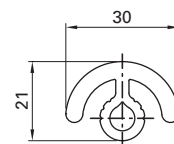

Application

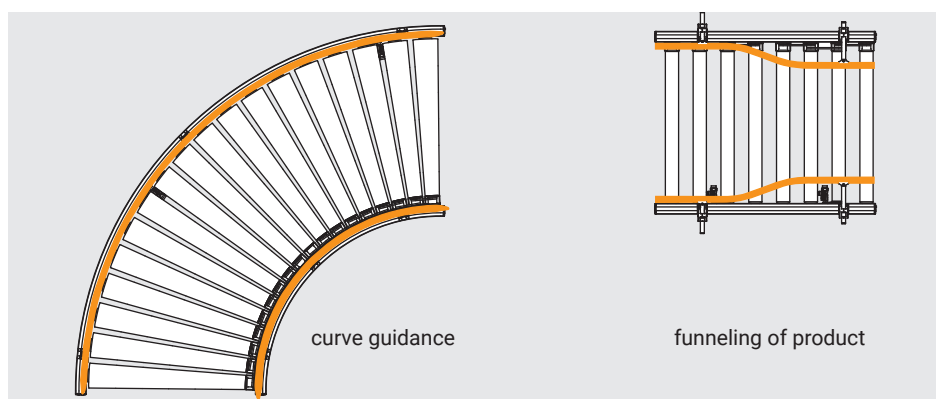

Order Code

Description	Order Code ¹	Weight/Meter
Side Guide Plastic, stock length 3000 mm	COL4590NNN	0.340 kg
Side Guide Plastic, cut to length	COL4590SNN	0.340 kg

1) Please complete the order by adding the corresponding parameters for order processing.
Drawing dimensions in mm