

Series CXT

ø12, ø16, ø20,
ø25, ø32, ø40

Replacement
Procedure is
P.290

Construction

CXTM
Guide rod/bearing

CXTL
Guide rod/bearing

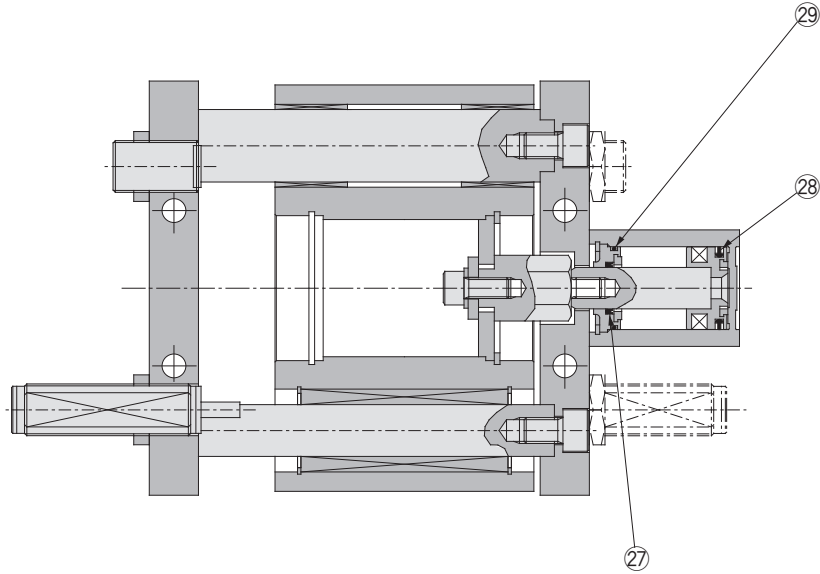

* The numbers are the same as the "Construction" of the Best Pneumatics No.3 Series CXT.

Seal Kit List

No.	Description	Material	Note
27	Rod seal	NBR	
28	Piston seal		
29 ^{Note)}	Tube gasket		

Note) The same type of the part is equipped to the head side for the long stroke type.

Replacement Parts: Seal Kit

Model	Cylinder	Kit no
Standard stroke		
CXT□12	CDQSB12	CQSB12-PS
CXT□16	CDQSB16	CQSB16-PS
CXT□20	CDQSB20	CQSB20-PS
CXT□25	CDQSB25	CQSB25-PS
CXT□32	CDQ2A32	CQ2B32-PS
CXT□40	CDQ2A40	CQ2B40-PS
Long stroke		
CXT□12	CDQSB12	CQSB12-L-PS
CXT□16	CDQSB16	CQSB16-L-PS
CXT□20	CDQSB20	CQSB20-L-PS
CXT□25	CDQSB25	CQSB25-L-PS
CXT□32	CDQ2A32	CQ2A32-L-PS
CXT□40	CDQ2A40	CQ2A40-L-PS

* Seal kit includes 27, 28 and 29. Order the seal kit with the kit number.

* Since the seal kit does not include a grease pack, order it separately.

Grease pack part no.: GR-S-010 (10 g)

Actuators

Modular F.R.L.
Pressure Control Equipment

Air Preparation
Equipment

Industrial Filters

Replacement
Procedure

Actuators

Modular F.R.L.
Pressure Control Equipment

Industrial Filters