

Series RHC

ø20, ø25, ø32, ø40
ø50, ø63, ø80, ø100

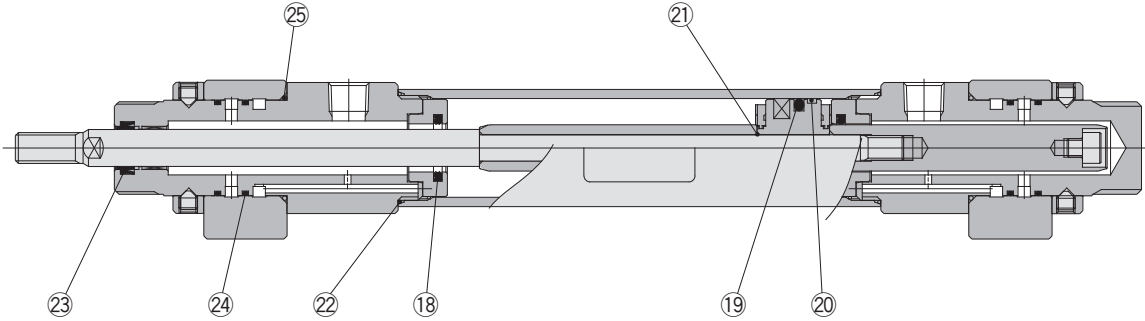

Construction



* The numbers are the same as the "Construction" of the Best Pneumatics No.3 Series RHC.

Seal Kit List

No.	Description	Material	Note
18	Cushion seal	Special resin	21 is a non-replaceable part, so it is not included in the seal kit.
19	Piston seal	NBR	
20	Wear ring	Resin	
21	Piston gasket	NBR	
22	Cylinder tube gasket	NBR	
23	Rod seal	NBR	
24	O-ring	NBR	
25	O-ring	NBR	

Replacement Parts: Seal Kit

Bore size (mm)	Kit no.	Contents
20	RHC20-PS	Set of left nos. 18, 19, 20, 22, 23, 24, 25
25	RHC25-PS	
32	RHC32-PS	
40	RHC40-PS	

* Seal kit includes a grease pack (10 g).
Order with the following part number when only the grease pack is needed.

Grease pack part no.: GR-S-010 (10 g)

⚠ Caution

When disassembling cylinders with bore sizes of ø20 through ø40, grip the double flat part of either the rod cover or the head cover with a vise and loosen the other side with a wrench or an adjustable angle wrench, and then remove the cover. When retightening, tighten approximately 2 degrees more than the original position.