

3 Position Cylinder

Series RZQ

ø32, ø40, ø50, ø63

Replacement
Procedure is
P.367

Construction

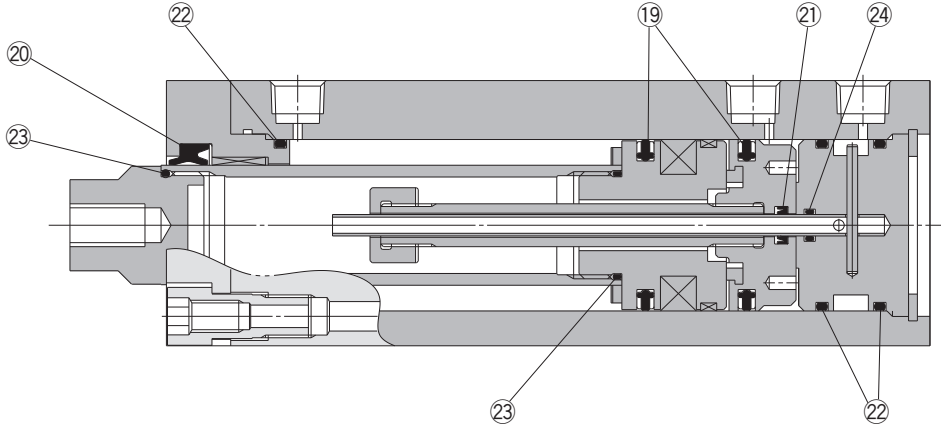

* The numbers are the same as the "Construction" of the Best Pneumatics No.3 Series RZQ.

Seal Kit List

No.	Description	Material	Note
19	Piston seal	NBR	23 is a non-replaceable part, so it is not included in the seal kit.
20	Rod seal A		
21	Rod seal B		
22	Gasket A		
23	Gasket B		
24	Gasket C		

Replacement Parts: Seal Kit

Bore size (mm)	Kit no.	Contents
32	RZQ32-PS	Set of left nos. 19, 20, 21, 22, 24
40	RZQ40-PS	
50	RZQ50-PS	
63	RZQ63-PS	

* Seal kits are sets consisting of items 19, 20, 21, 22 and 24 and can be ordered using the seal kit number for each cylinder bore size.

* Since the seal kit does not include a grease pack, order it separately.
Grease pack part no. GR-L-010 (10 g)