

Series CH□KD

ø20, ø25
ø32, ø40
ø50, ø63
ø80, ø100

Replacement
Procedure is
P.392

Construction

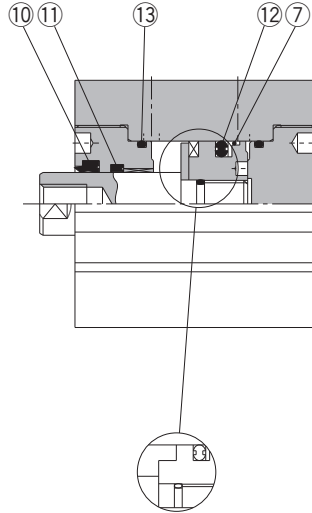

Without auto switch

* The numbers are the same as the "Construction" of the Best Pneumatics No.8 Series CH□KD.

Seal Kit List

No.	Description	Material	Note
⑦	Back-up ring	Resin	
⑩	Scraper	NBR	
⑪	Rod seal		
⑫	Piston seal		
⑬	Tube gasket		

Replacement Parts: Seal Kit

Bore size (mm)	Seal kit no.	Content
20	CHKD20-PS	Set of left nos. ⑦, ⑩, ⑪, ⑫, ⑬
25	CHKD25-PS	
32	CHKD32-PS	
40	CHKD40-PS	
50	CHKD50-PS	
63	CHKD63-PS	
80	CHKD80-PS	
100	CHKD100-PS	

* Seal kit consists of items ⑦, ⑩, ⑪, ⑫ and ⑬, and can be ordered by using the seal kit number for each bore size.

* Special tools are necessary for disassembly. Contact SMC for recommended tool designs and dimensions. Furthermore, ø80 and ø100 are tightened with a large tightening torque, so disassembly will be difficult. Contact SMC if disassembly is required.

Actuators

Modular F.R.L.
Pressure Control Equipment

Air Preparation
Equipment

Industrial Filters

Replacement
Procedure

Actuators

Modular F.R.L.
Pressure Control Equipment

Industrial Filters