

Mechanically Jointed Rodless Cylinder/Linear Guide Type

Series MY1H $\phi 10$

Replacement
Procedure is
P.310

Construction

Centralized piping type: $\phi 10$

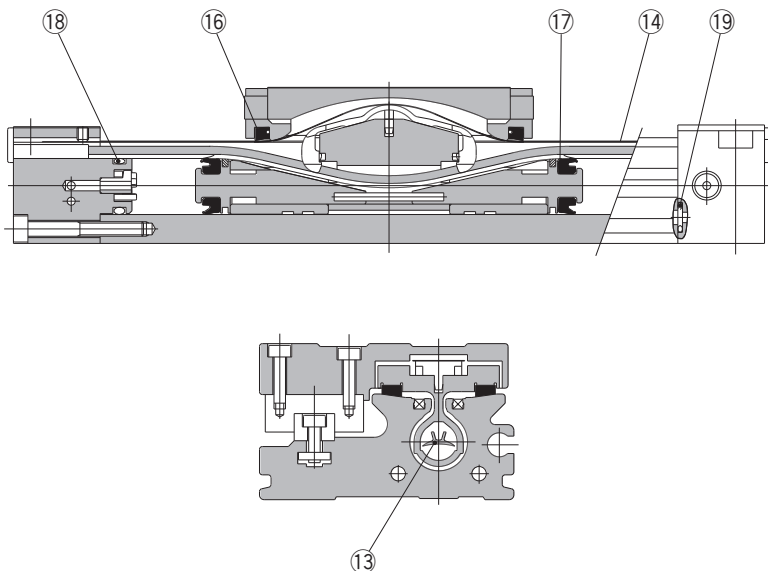

* The numbers are the same as the "Construction" of the Best Pneumatics No.2 Series MY1H.

Replacement Parts: Seal Kit

No.	Description	Qty.	MY1H10	Note
13	Seal belt	1	MY10-16A-Stroke	13 and 14 are not included in the seal kit. Order them as required with by individual part numbers.
14	Dust seal band	1	MY10-16B-Stroke	
16	Scraper	2	MY1B10-PS	
17	Piston seal	2		
18	Tube gasket	2		
19	O-ring	4		

* Seal kit includes 16, 17, 18 and 19.

Seal kit includes a grease pack (10 g).

When 13 and 14 are shipped independently, a grease pack is included.

Order with the following part number when only the grease pack is needed.

Grease pack part no.: GR-S-010 (10 g), GR-S-020 (20 g)

Actuators

Modular F.R.L.
Pressure Control Equipment

Air Preparation
Equipment

Industrial Filters

Replacement
Procedure

Actuators

Modular F.R.L.
Pressure Control Equipment

Industrial Filters

Mechanically Jointed Rodless Cylinder/Linear Guide Type

Series MY1H

ø16, ø20, ø25
ø32, ø40

Replacement
Procedure is
P.310

Construction

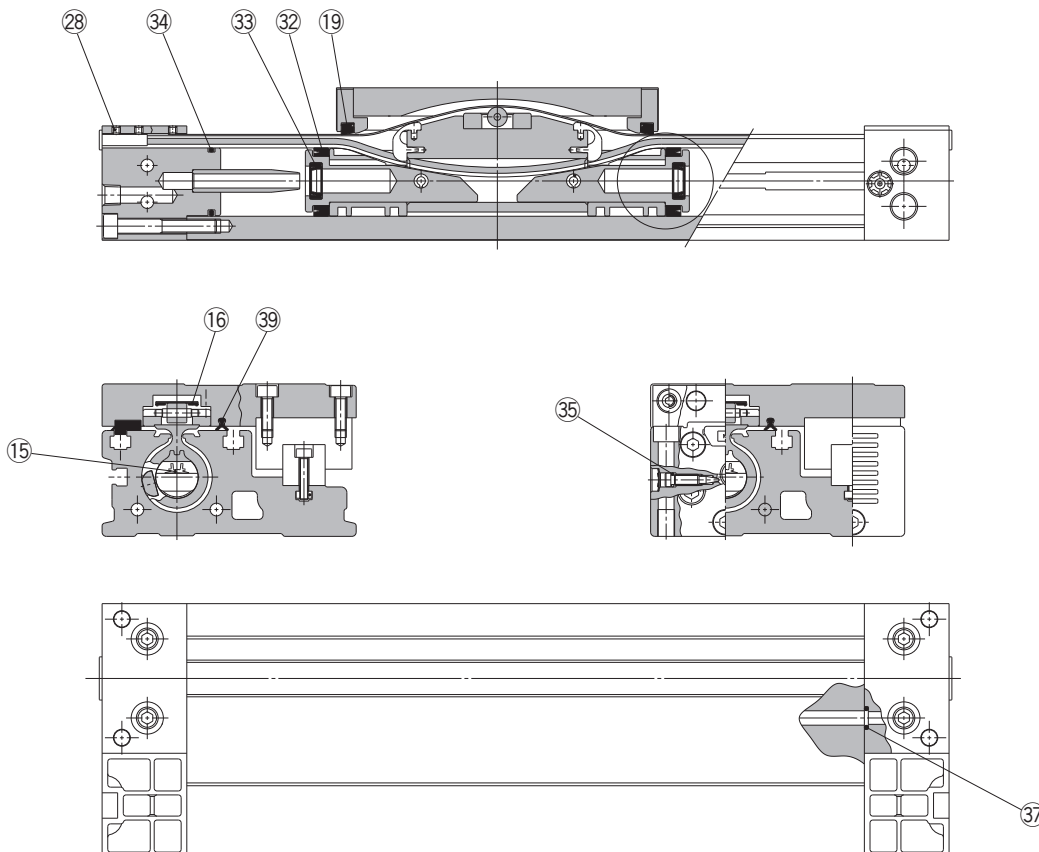

* The numbers are the same as the "Construction" of the Best Pneumatics No.2 Series MY1H.

Replacement Parts: Seal Kit (15, 16, 35 and 39 are not included in the seal kit. Order them as required with by individual part numbers.)

No.	Description	Qty.	MY1H16	MY1H20	MY1H25	MY1H32	MY1H40
15	Seal belt	1	MY16-16A-[Stroke]	MY20-16A-[Stroke]	MY25-16A-[Stroke]	MY32-16A-[Stroke]	MY40-16A-[Stroke]
16	Dust seal band	1	MY16-16B-[Stroke]	MY20-16B-[Stroke]	MY25-16B-[Stroke]	MY32-16B-[Stroke]	MY40-16B-[Stroke]
35	O-ring	2	KA00309 (ø4 x ø1.8 x ø1.1)	KA00309 (ø4 x ø1.8 x ø1.1)	KA00311 (ø5.1 x ø3 x ø1.05)	KA00320 (ø7.15 x ø3.75 x ø1.7)	KA00320 (ø7.15 x ø3.75 x ø1.7)
39	Side scraper	1	MYH16-15BK2900B	MYH20-15BK2901B	MYH25-15BK2902B	MYH32-15BK2903B	MYH40-15BK2904B
19	Scraper	2					
32	Piston seal	2					
33	Cushion seal	2	MY1H16-PS	MY1H20-PS	MY1H25-PS	MY1H32-PS	MY1H40-PS
34	Tube gasket	2					
37	O-ring	4					

* Seal kit includes 19, 32, 33, 34 and 37. Order the seal kit based on each bore size.

* Seal kit includes a grease pack (10 g).

When 15 and 16 are shipped independently, a grease pack (20 g) is included.

Order with the following part number when only the grease pack is needed.

Grease pack part no.: GR-S-010 (10 g), GR-S-020 (20 g)

Note) Two kinds of dust seal bands are available. Verify the type to use, since the part number varies depending on the treatment of the hexagon socket head set screw 28.

A: Black zinc chromated → MY□□-16B-stroke, B: Nickel plated → MY□□-16BW-stroke

Mechanically Jointed Rodless Cylinder/Linear Guide Type

Series MY1H

ø16, ø20, ø25
ø32, ø40

Replacement
Procedure is
P.310

Construction

With End Lock: ø16 to ø40

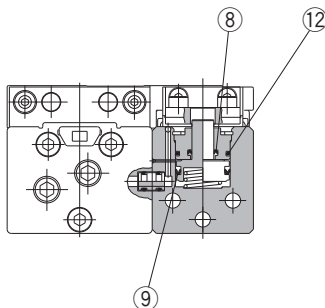

* The numbers are the same as the "Construction" of the Best Pneumatics No.2 Series MY1H.

Replacement Parts: Seal

No.	Description	Material	Qty.	MY1H16	MY1H20	MY1H25	MY1H32	MY1H40
8	Rod seal	NBR	1	KB00257	KB00257	KB00267	KB00267	KB00267
9	Piston seal		1	KB00202	KB00202	KB00217	KB00217	KB00217
12	O-ring		1	KA00057	KA00057	KA00037	KA00037	KA00037

* Since the seal kit does not include a grease pack, order it separately.

Grease pack part no.: GR-S-010 (10 g)

Actuators

Modular F.R.L.
Pressure Control Equipment

Air Preparation
Equipment

Industrial Filters

Replacement
Procedure

Actuators

Modular F.R.L.
Pressure Control Equipment

Industrial Filters