

# Series MY2C

ø16, ø25, ø40

Replacement  
Procedure is  
P.311

## Construction

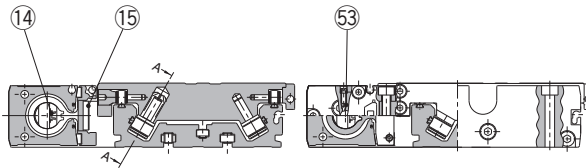
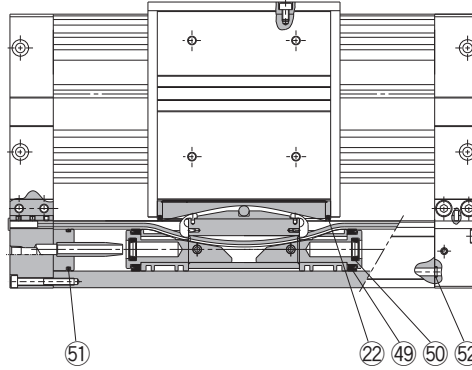

\* The numbers are the same as the "Construction" of the Best Pneumatics No.2 Series MY2C.

### Replacement Parts: Seal Kit

| No. | Description    | Qty. | MY2C16G                       | MY2C25G                       | MY2C40G                           | Note  |
|-----|----------------|------|-------------------------------|-------------------------------|-----------------------------------|---|
| 14  | Seal belt      | 1    | MY16-16A-[Stroke]             | MY25-16A-[Stroke]             | MY40-16A-[Stroke]                 | 14, 15 and 53 are not included in the seal kit. Order them as required with by individual part numbers. |
| 15  | Dust seal band | 1    | MY2H16-16B-[Stroke]           | MY2H25-16B-[Stroke]           | MY2H40-16B-[Stroke]               |   |
| 53  | O-ring         | 2    | KA00309<br>(ø4 x ø1.8 x ø1.1) | KA00309<br>(ø4 x ø1.8 x ø1.1) | KA00320<br>(ø7.15 x ø3.75 x ø1.7) |   |
| 22  | Scraper        | 2    | MY2B16-PS                     | MY2B25-PS                     | MY1B40-PS                         |   |
| 49  | Piston seal    | 2    |                               |                               |                                   |   |
| 50  | Cushion seal   | 2    |                               |                               |                                   |   |
| 51  | Tube gasket    | 2    |                               |                               |                                   |   |
| 52  | O-ring         | 4    |                               |                               |                                   |   |

\* Seal kit includes 22, 49, 50, 51 and 52. Order the seal kit based on each bore size.

\* Seal kit includes a grease pack (10 g).

When 14 and 15 are shipped as single units, a grease pack (10 g per 1000 strokes) is included.

Order with the following part number when only the grease pack is needed.

Grease pack part no.: GR-S-010 (10 g), GR-S-020 (20 g)

Actuators

Modular F.R.L.  
Pressure Control Equipment

Air Preparation  
Equipment

Industrial Filters

Replacement  
Procedure

Actuators

Modular F.R.L.  
Pressure Control Equipment

Industrial Filters