

Compact Cylinder/Standard Type: Double Acting, Double Rod

Series CQ2W

∅12, ∅16, ∅20
 ∅25, ∅32, ∅40
 ∅50, ∅63, ∅80
 ∅100

Replacement
 Procedure is
 P.290

Construction

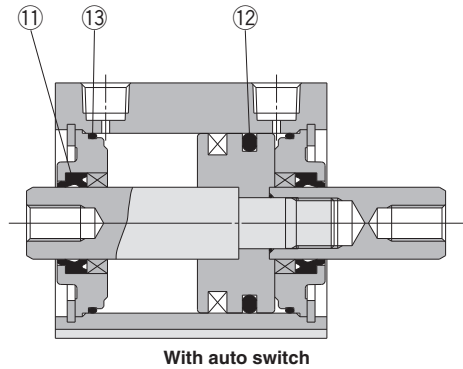
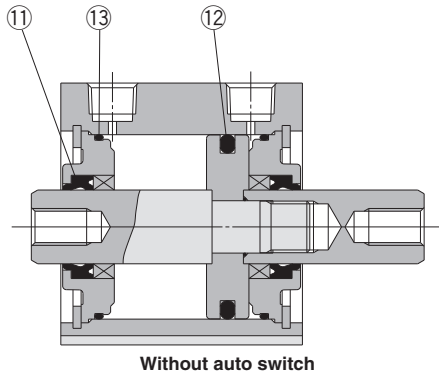

* The numbers are the same as the "Construction" of the CQ2 series catalog (CAT.ES20-205).

Seal Kit List

No.	Description	Material	Note
⑪	Rod seal	NBR	
⑫	Piston seal		
⑬	Tube gasket		

Replacement Parts: Seal Kit

Bore size (mm)	Kit no.	Contents
Pneumatic type		
12	CQ2WB12-PS	Set of left nos. ⑪, ⑫, ⑬.
16	CQ2WB16-PS	
20	CQ2WB20-PS	
25	CQ2WB25-PS	
32	CQ2WB32-PS	
40	CQ2WB40-PS	
50	CQ2WB50-PS	
63	CQ2WB63-PS	
80	CQ2WB80-PS	
100	CQ2WB100-PS	

* Seal kit includes ⑪, ⑫, ⑬. Order the seal kit, based on each bore size.

* Since the seal kit does not include a grease pack, order it separately.

Grease pack part no.: GR-S-010 (10 g)

Air-hydro type

20	CQ2WBH20-PS	Set of left nos. ⑪, ⑫, ⑬.
25	CQ2WBH25-PS	
32	CQ2WBH32-PS	
40	CQ2WBH40-PS	
50	CQ2WBH50-PS	
63	CQ2WBH63-PS	
80	CQ2WBH80-PS	
100	CQ2WBH100-PS	

* Seal kit includes ⑪, ⑫, ⑬. Order the seal kit, based on each bore size.

* Since the seal kit does not include a grease pack, order it separately.

Grease pack part no.: GR-S-010 (10 g)

Actuators

Modular F.R.L.
Pressure Control Equipment

Air Preparation
Equipment

Industrial Filters

Replacement
Procedure

Actuators

Modular F.R.L.
Pressure Control Equipment

Industrial Filters

Series CQ2W

∅125, ∅140, ∅160
∅180, ∅200



Construction

Standard

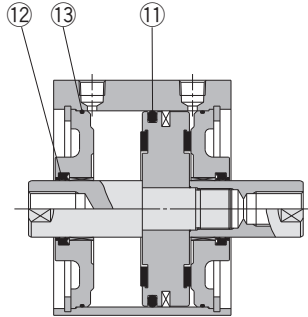

* The numbers are the same as the "Construction" of the CQ2 series catalog (CAT.ES20-205).

Seal Kit List

No.	Description	Material	Note
①	Piston seal	NBR	
⑫	Rod seal		
⑬	Tube gasket		

Replacement Parts: Seal Kit

Bore size (mm)	Kit no.	Contents
125	CQ2WB125-PS	Set of left nos. ①, ⑫, ⑬.
140	CQ2WB140-PS	
160	CQ2WB160-PS	
180	CQ2WB180-PS	
200	CQ2WB200-PS	

* Seal kit includes ①, ⑫, ⑬. Order the seal kit, based on each bore size.

* Since the seal kit does not include a grease pack, order it separately.

Grease pack part no.: GR-S-010 (10 g)