



Modular Style Regulator with Built-in Pressure Gauge *Series ARG*

Regulator with Built-in Pressure Gauge Series ARG	Model	Port size	Accessory
 <p data-bbox="151 929 359 958">Pages 20 to 23</p>	ARG20	1/8, 1/4	Bracket Set nut for changing the mounting angle of pressure gauges
	ARG30	1/4, 3/8	
	ARG40	1/4, 3/8, 1/2	
 <p data-bbox="151 1366 359 1397">Pages 24 to 28</p>	ARG20K	1/8, 1/4	
	ARG30K	1/4, 3/8	
	ARG40K	1/4, 3/8, 1/2	

Regulator with Built-in Pressure Gauge

Series ARG20/30/40

How to Order



ARG 20 [] 01 [] G1 [] []

Body size

Symbol	Port size
20	1/8
30	3/8
40	1/2

Thread type

Symbol	Type
Nil	Rc
N	NPT
F	G

Port size

Symbol	Port size	Body size		
		20	30	40
01	1/8	●	—	—
02	1/4	●	●	●
03	3/8	—	●	●
04	1/2	—	—	●

Option

Symbol	Description
Nil	—
1 ⁽²⁾	0.02 to 0.2 MPa setting
N	Non-relieving type
Z ⁽³⁾	Name plate and pressure gauge in imperial units (PSI)



* When more than one specification is required, indicate in ascending alphanumeric order.

Note 2) Adjusting spring and pressure gauge (full-span 0.3 MPa) are different from those for the standard specification.

Outlet pressure may increase by 0.2 MPa or more.

Note 3) For thread type NPT.

This product is for overseas use only according to the new Measurement Law (The SI unit type is provided for use in Japan.)

Accessory (2)

Symbol	Description
Nil	—
H	With set nut

Accessory (1)

Symbol	Description
Nil	—
B	With bracket (With nuts)

JIS Symbol

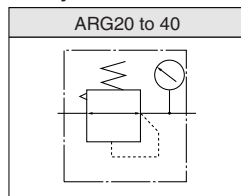

Mounting Angle of Pressure Gauge

Symbol	G1	G2	G3	G4
Mounting angle	0°	90°	180°	270°
Mounting angle view				

* Mounting angles other than 45°, 135°, 225° and 315° are available through the Made to Order (page 29).

* Possible to change to the optional mounting angles.

For details, refer to the back of page 6, "Procedure for replacing or changing the mounting angle of a pressure gauge"

⊙: Combination available

■: Combination not available

△: Available only with NPT thread

Accessory/Optional Combinations

Accessory/Optional specifications		Combination Symbol	Accessory		Option			Applicable regulator
			B	H	1	N	Z	
Accessory	With bracket	B	■	■	⊙	⊙	△	⊙
	With set nut	H	■	■	⊙	⊙	△	⊙
Option	0.02 to 0.2 MPa setting	-1	⊙	⊙	■	⊙	△	⊙
	Non-relieving type	-N	⊙	⊙	⊙	■	△	⊙
	Name plate and pressure gauge in imperial units (PSI)	-Z	△	△	△	△	■	△

Regulator with Built-in Pressure Gauge *Series ARG20/30/40*

Standard Specifications

Model	ARG20	ARG30	ARG40
Port size	1/8, 1/4	1/4, 3/8	1/4, 3/8, 1/2
Fluid	Air		
Proof pressure	1.5 MPa		
Maximum operating pressure	1.0 MPa		
Regulating pressure range	0.05 to 0.85 MPa		
Relief pressure	Set pressure + 0.05 MPa (at relief flow rate of 0.1 ℓ/min (ANR))		
Ambient and fluid temperature	-5° to 60°C (With no freezing)		
Construction	Relieving type		
Weight (kg)	0.31	0.40	0.57

Accessory Part No.

Accessory		Applicable model	ARG20	ARG30	ARG40	
Bracket assembly ⁽¹⁾			ARG20P-270AS	ARG30P-270AS	ARG40P-270AS	
Set nut			ARG20P-260S	ARG30P-260S	ARG40P-260S	
Pressure gauge	Pressure gauge display range	Standard	0 to 1.0 MPa	GB2-10AS	GB3-10AS	GB4-10AS
		Optional	0 to 0.3 MPa	GB2-3AS	GB3-3AS	GB4-3AS
			0 to 150 PSI	GB2-P10AS	GB3-P10AS	GB4-P10AS
			0 to 45 PSI	GB2-P3AS	GB3-P3AS	GB4-P3AS

Note 1) Assembly includes a bracket and set nuts.

Flow Characteristics (Representative values)

Condition: Inlet pressure 0.7 MPa

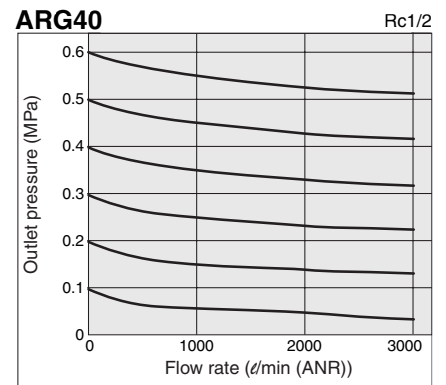
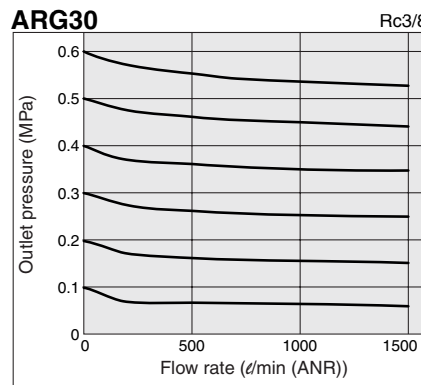
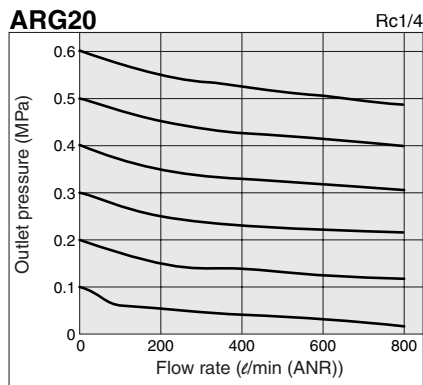

Pressure Characteristics (Representative values)

Conditions: Inlet pressure 0.7 MPa, Outlet pressure 0.2 MPa, Flow rate 20 ℓ/min (ANR)

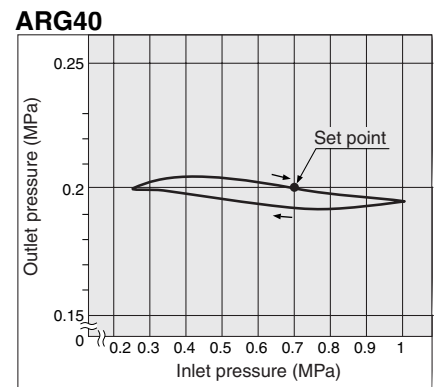
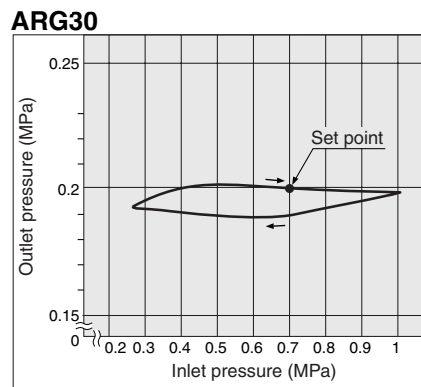
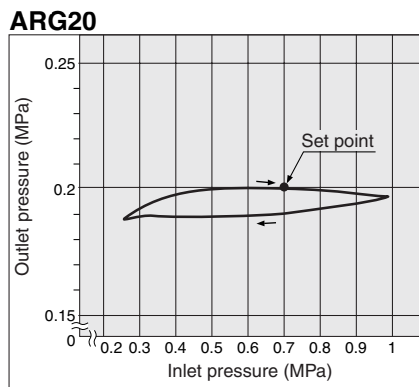

Series ARG20/30/40

⚠ Specific Product Precautions

Be sure to read before handling. Refer to the back of pages 1 through to 5 for Safety Instructions and Precautions.

Mounting and Adjustment

⚠ Warning

- 1 Set the regulator while verifying the displayed values of the inlet and outlet pressure gauges. Turning the regulator handle excessively can cause damage to the internal parts.
2. Do not use tools on the pressure regulator handle as this may cause damage. It must be operated manually.

⚠ Caution

- 1 Be sure to unlock the handle before adjusting the pressure and lock it after setting the pressure.
Failure to follow this procedure can cause damage to the handle and the outlet pressure may fluctuate.
 - Pull the pressure regulator handle to unlock. (You can visually verify this with the "orange mark" that appears in the gap.)
 - Push the pressure regulator handle to lock. When the handle is not easily locked, turn it left and right a little and then push it (when the handle is locked, the "orange mark" i.e., the gap will disappear).

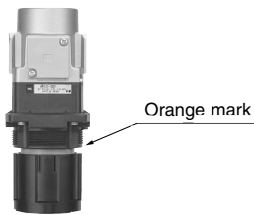

2. When using the regulator between a solenoid valve and an actuator, check the pressure gauge periodically.

Construction

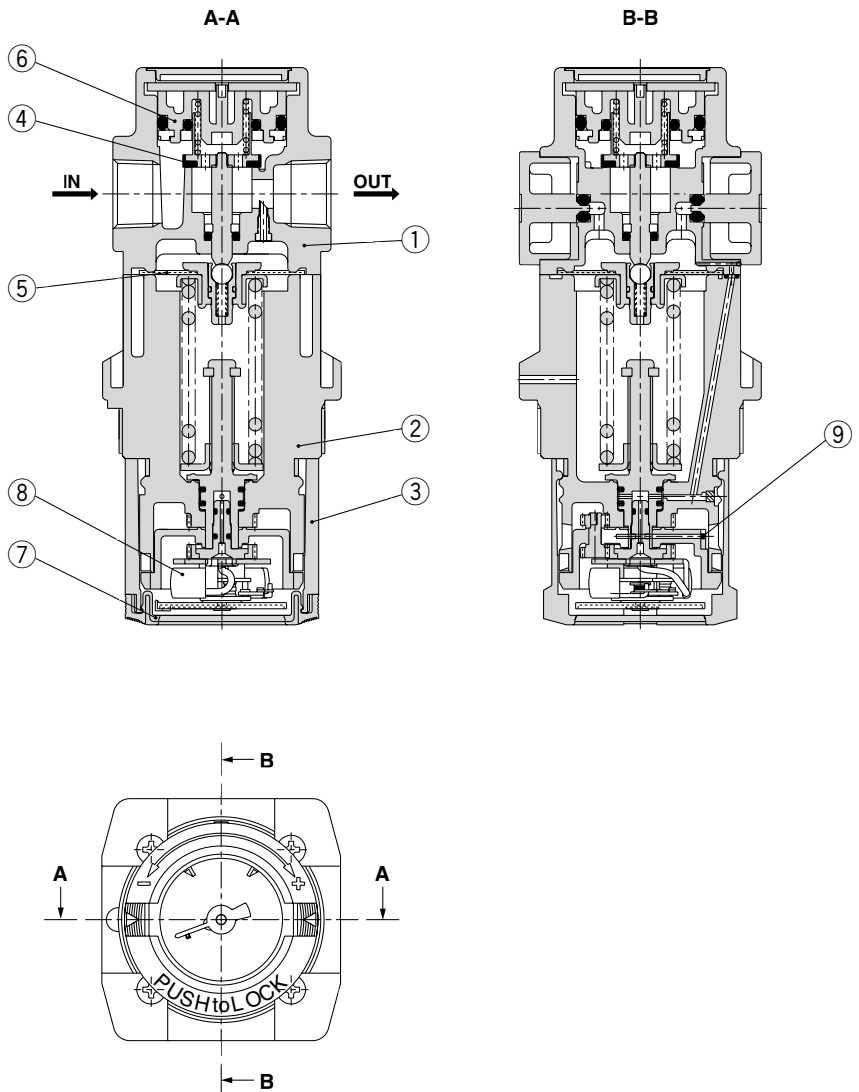

Component Parts

No.	Description	Material			Note
		ARG20	ARG30	ARG40	
1	Body	ZDC	ADC		Platinum silver
2	Bonnet	PBT			Black
3	Handle	POM			Black

Replacement Parts

No.	Description	Material	Part no.		
			ARG20	ARG30	ARG40
4	Valve	Brass, HNBR	AR20P-410S	AR30P-410S	AR40P-410S
5	Diaphragm assembly	Weatherability NBR	AR20P-150AS	AR30P-150AS	AR40P-150AS
6	Valve guide assembly	POM, NBR	AR20P-050AS	AR30P-050AS	AR40P-050AS
7	Pressure gauge cover	PC	ARG20P-400S	ARG30P-400S	ARG40P-400S
8	Pressure gauge	—	GB2-10AS	GB3-10AS	GB4-10AS
9	Clip	Stainless steel	ARG20P-420S	ARG30P-420S	ARG40P-420S

Note) Only the standard part numbers are listed in the pressure gauges. For the optional part numbers, refer to page 21

Dimensions

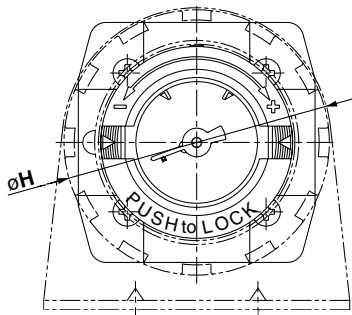
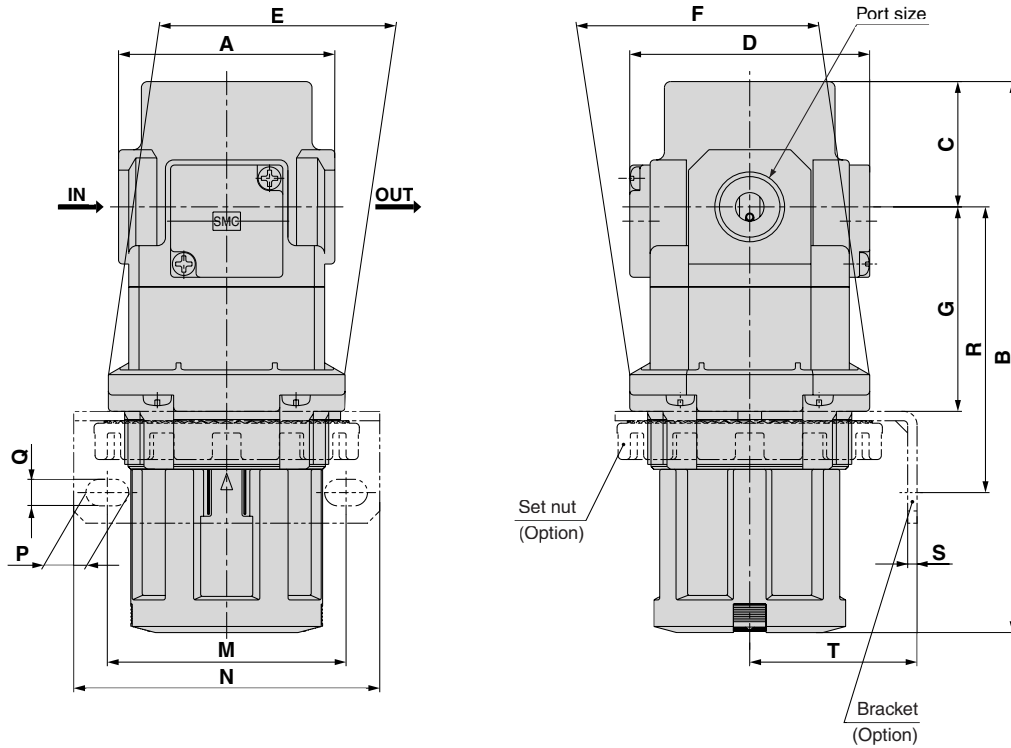

Panel fitting dimension

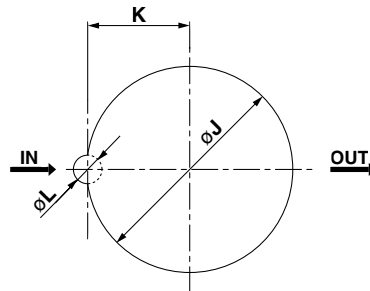

Plate thickness
ARG20 to 40: Max. 3.5

Model	Port size	Standard specifications						Accessory specifications											
		A	B	C	D	E	F	Panel mount						Bracket mount					
								G	H	J	K	L	M	N	P	Q	R	S	T
ARG20	1/8, 1/4	40	114	26.5	57	45	47	38	52.5	39.5	19.5	6	48	65	10.4	5.4	60	2.3	35
ARG30	1/4, 3/8	53	138.5	31	59	58	59	50	65	50.5	25	7	59	75	10.5	6.5	70	2.3	45
ARG40	1/4, 3/8, 1/2	70	150.5	36	68	70	70	54	70	55.5	27.5	7	65.5	85	12.5	8.5	75	2.3	50

Regulator with Built-in Pressure Gauge with Back Flow Mechanism

Series ARG20K/30K/40K

How to Order



ARG20K



ARG40K

ARG 20 K- 01 G1

Body size

Symbol	Port size
20	1/8
30	3/8
40	1/2

With back flow mechanism

Note 1) If the set pressure is not exceeding 0.15 MPa, back flow may not occur. Contact SMC when a back flow mechanism is required with a set pressure of less than 0.15 MPa.

Thread type

Symbol	Type
Nil	Rc
N	NPT
F	G

Port size

Symbol	Port size	Body size		
		20	30	40
01	1/8	●	—	—
02	1/4	●	●	●
03	3/8	—	●	●
04	1/2	—	—	●

Option

Symbol	Description
Nil	—
1 ⁽²⁾	0.02 to 0.2 MPa setting
N	Non-relieving type
Z ⁽³⁾	Name plate and pressure gauge in imperial units (PSI)

* When more than one specification is required, indicate in ascending alphanumeric order.

Note 2) Adjusting spring and pressure gauge (full-span 0.3 MPa) are different from those for the standard specification.

Outlet pressure may increase by 0.2 MPa or more.

Note 3) For thread type NPT.

This product is for overseas use only according to the new Measurement Law. (The SI unit type is provided for use in Japan.)

Accessory (2)

Symbol	Description
Nil	—
H	With set nut

Accessory (1)

Symbol	Description
Nil	—
B	With bracket (With nuts)

Mounting Angle of Pressure Gauge

Symbol	G1	G2	G3	G4
Mounting angle	0°	90°	180°	270°
Mounting angle view				

* Mounting angles other than 45°, 135°, 225° and 315° are available through the Made to Order (page 29).

* Possible to change to the optional mounting angles.

For details, refer to the back of page 6, "Procedure for replacing or changing the mounting angle of a pressure gauge"

JIS Symbol

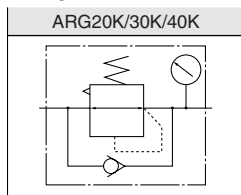

Accessory/Optional Combinations

- ◎: Combination available
- : Varies depending on a model
- : Combination not available
- △: Available only with NPT thread

Accessory/Optional specifications	Combination Symbol	Accessory			Option			Applicable regulator ARG20 to 40
		B	H	1	N	Z		
Accessory	With bracket	■	■	◎	◎	△	◎	
	With set nut	■	■	◎	◎	△	◎	
Option	0.02 to 0.2 MPa setting	◎	◎	■	◎	△	◎	
	Non-relieving type	◎	◎	◎	■	△	◎	
	Name plate and pressure gauge in imperial units (PSI)	△	△	△	△	■	△	

Application examples of a regulator with a back flow mechanism

With a built-in mechanism which enables reliable discharge of air pressure from outlet to inlet

Example 1)

When the pressure in the rear and the front of the cylinder differs:

Circuit diagram

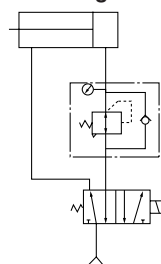

Example 2)

When the air supply is cut off and releasing the inlet pressure to the atmosphere, the residual pressure release of the outlet side can be ensured for a safety purpose.

Circuit diagram

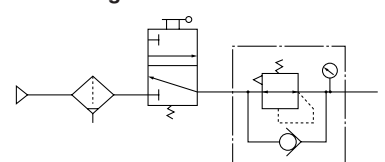

Regulator with Built-in Pressure Gauge with Back Flow Mechanism *Series ARG20K/30K/40K*

Standard Specifications

Model	ARG20K	ARG30K	ARG40K
Port size	1/8, 1/4	1/4, 3/8	1/4, 3/8, 1/2
Fluid	Air		
Proof pressure	1.5 MPa		
Maximum operating pressure	1.0 MPa		
Regulating pressure range ⁽¹⁾	0.05 to 0.85 MPa		
Relief pressure	Set pressure + 0.05 MPa (at relief flow rate of 0.1 ℓ/min (ANR))		
Ambient and fluid temperature	-5° to 60°C (With no freezing)		
Construction	Relieving type		
Weight (kg)	0.31	0.40	0.57

Note 1) Set the inlet pressure to 0.05 MPa or higher than the set pressure.

Accessory Part No.

Accessory		Applicable model	ARG20K	ARG30K	ARG40K	
Bracket assembly ⁽¹⁾			ARG20P-270AS	ARG30P-270AS	ARG40P-270AS	
Set nut			ARG20P-260S	ARG30P-260S	ARG40P-260S	
Pressure gauge	Pressure gauge display range	Standard	0 to 1.0 MPa	GB2-10AS	GB3-10AS	GB4-10AS
		Optional	0 to 0.3 MPa	GB2-3AS	GB3-3AS	GB4-3AS
			0 to 150 PSI	GB2-P10AS	GB3-P10AS	GB4-P10AS
			0 to 45 PSI	GB2-P3AS	GB3-P3AS	GB4-P3AS

Note 1) Assembly includes a bracket and set nuts.

Flow Characteristics (Representative values)

Condition: Inlet pressure 0.7 MPa

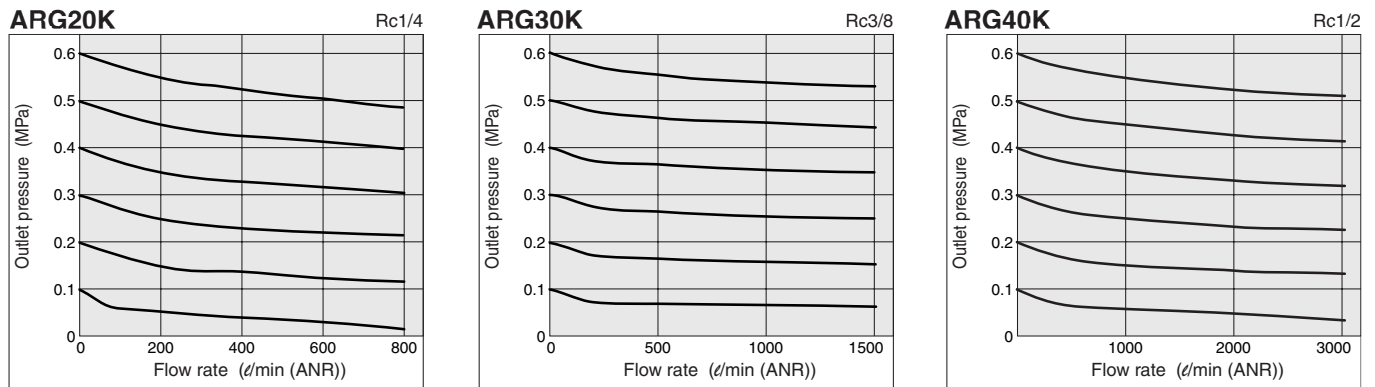

Pressure Characteristics (Representative values)

Conditions: Inlet pressure 0.7 MPa, Outlet pressure 0.2 MPa, Flow rate 20 ℓ/min (ANR)

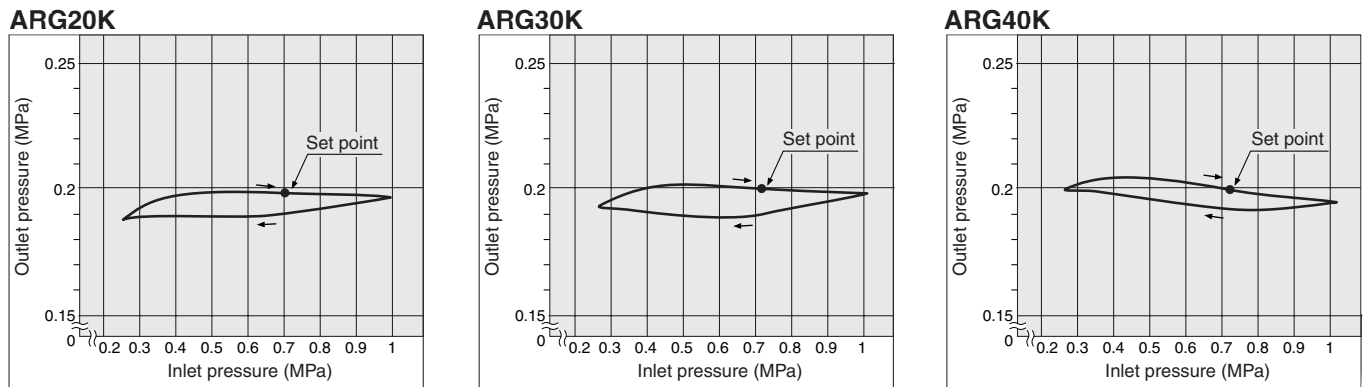

Series ARG20K/30K/40K

Working Principle

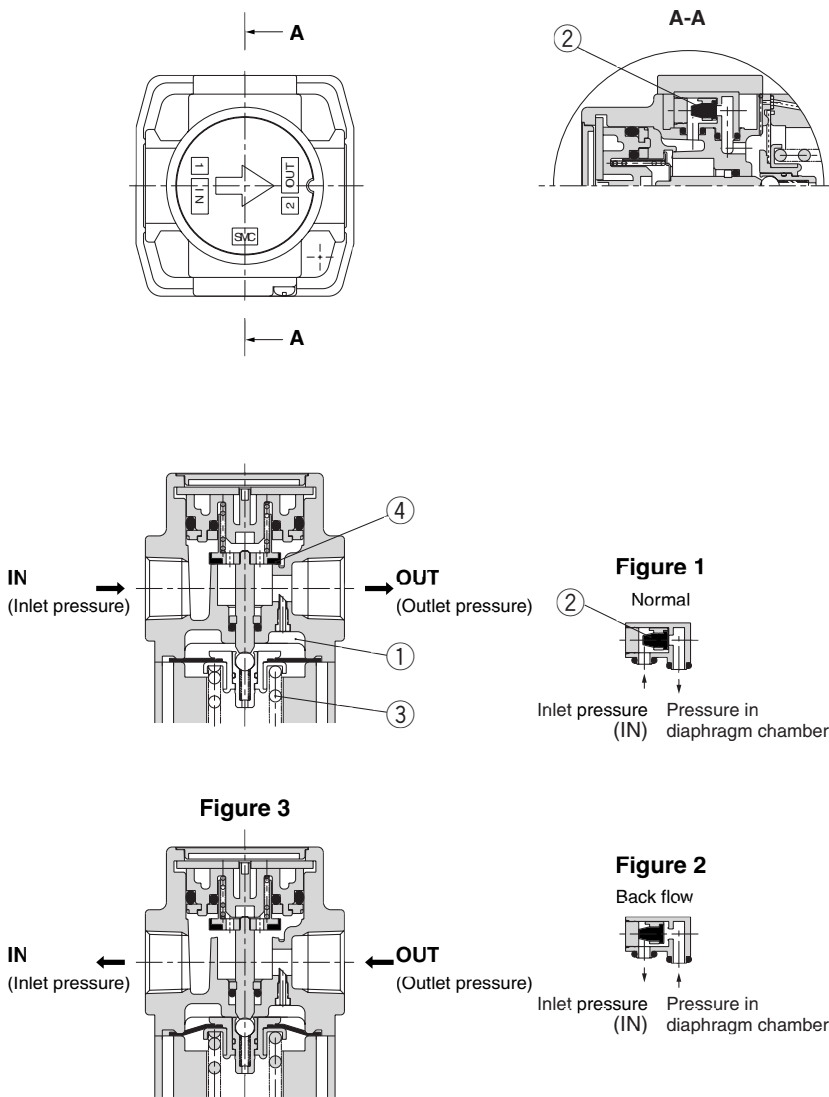

When the inlet pressure (P_1) is higher than the regulating pressure, the check valve ② closes and operates as a normal regulator (Figure 1)
 When the inlet pressure (P_1) is shut off and released, the check valve ② opens and the pressure in the diaphragm chamber ① is released into the inlet side (Figure 2)
 This lowers the pressure in the diaphragm chamber ① and the force generated by the pressure regulator spring ③ lifts the diaphragm. Valve ④ opens through the stem, and the outlet pressure is released to the inlet side (Figure 3).

⚠ Specific Product Precautions

Be sure to read before handling. Refer to the back of pages 1 through to 5 for Safety Instructions and Precautions.

Mounting and Adjustment

⚠ Warning

- 1 Set the regulator while verifying the displayed values of the inlet and outlet pressure gauges. Turning the regulator handle excessively can cause damage to the internal parts.
- 2 Do not use tools on the pressure regulator handle as this may cause damage. It must be operated manually.

⚠ Caution

- 1 Be sure to unlock the handle before adjusting the pressure and lock it after setting the pressure.
 Failure to follow this procedure can cause damage to the handle and the outlet pressure may fluctuate.



- Pull the pressure regulator handle to unlock. (You can visually verify this with the "orange mark" that appears in the gap.)
- Push the pressure regulator handle to lock. When the handle is not easily locked, turn it left and right a little and then push it (when the handle is locked, the "orange mark" i.e. the gap will disappear).

Maintenance

⚠ Warning

- 1 When using the regulator between a solenoid valve and an actuator, check the pressure gauge periodically. Sudden pressure fluctuations may shorten the durability of the pressure gauge.

Regulator with Built-in Pressure Gauge with Back Flow Mechanism *Series ARG20K/30K/40K*

Construction

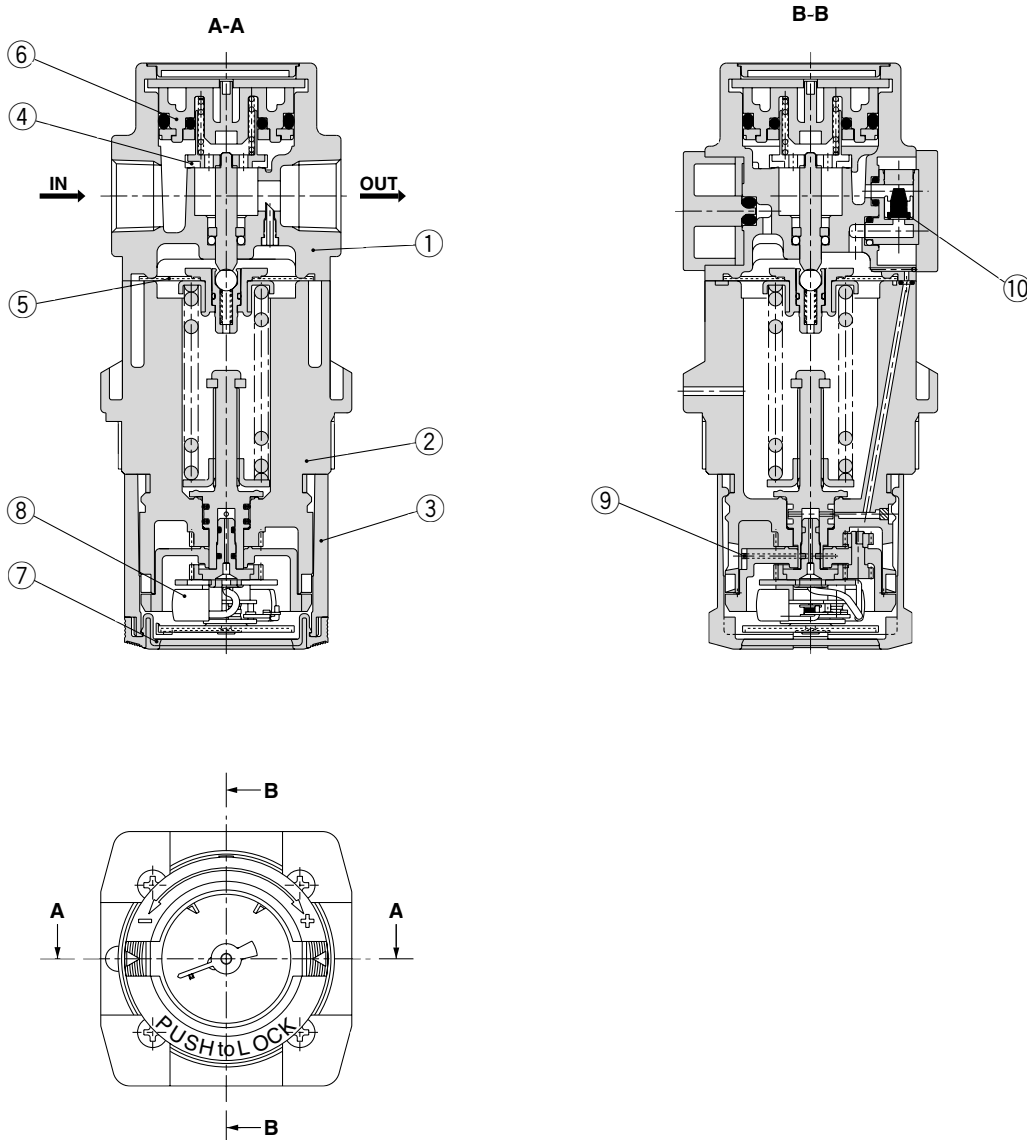

Component Parts

No.	Description	Material			Note
		ARG20	ARG30	ARG40	
1	Body	ZDC	ADC		Platinum silver
2	Bonnet	PBT			Black
3	Handle	POM			Black

Replacement Parts

No.	Description	Material	Part no.		
			ARG20	ARG30	ARG40
4	Valve	Brass, HNBR	AR20P-410S	AR30P-410S	AR40P-410S
5	Diaphragm assembly	Weatherability NBR	AR20P-150AS	AR30P-150AS	AR40P-150AS
6	Valve guide assembly	POM, NBR	AR20P-050AS	AR30P-050AS	AR40P-050AS
7	Pressure gauge cover	PC	ARG20P-400S	ARG30P-400S	ARG40P-400S
8	Pressure gauge ⁽¹⁾	—	GB2-10AS	GB3-10AS	GB4-10AS
9	Clip	Stainless steel	ARG20P-420S	ARG30P-420S	ARG40P-420S
10	Check valve assembly ⁽²⁾	—	AR20KP-020AS		

Note 1) Only the standard part numbers are listed for the pressure gauges. For the optional part numbers, refer to page 25.

Note 2) Check valve assembly contains check valve, check valve cover and its screws (2 pcs).

Series ARG20K/30K/40K

Construction

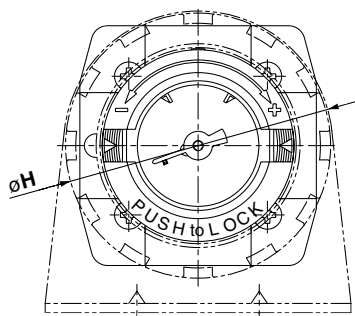
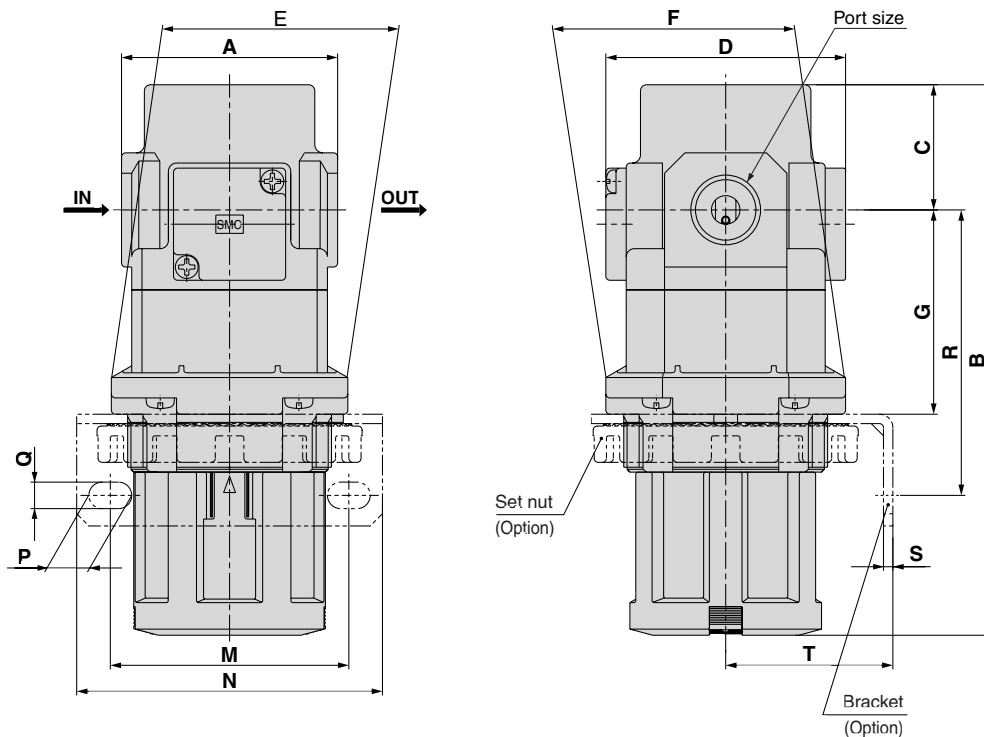

Panel fitting dimension

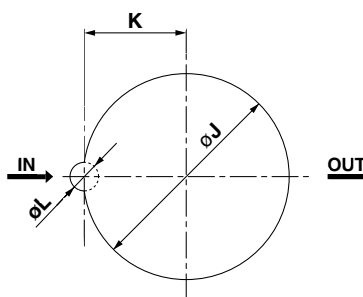

Plate thickness
ARG20K to 40K: Max. 3.5

Model	Port size	Standard specifications						Accessory specifications											
		A	B	C	D	E	F	Panel mount						Bracket mount					
								G	H	J	K	L	M	N	P	Q	R	S	T
ARG20K	1/8, 1/4	40	114	26.5	57	45	47	38	52.5	39.5	19.5	6	48	65	10.4	5.4	60	2.3	35
ARG30K	1/4, 3/8	53	138.5	31	59	58	59	50	65	50.5	25	7	59	75	10.5	6.5	70	2.3	45
ARG40K	1/4, 3/8, 1/2	70	150.5	36	68	70	70	54	70	55.5	27.5	7	65.5	85	12.5	8.5	75	2.3	50

Regulator with Built-in Pressure Gauge ARG20/30/40 Made to Order



Contact SMC for detailed dimensions, specifications, and lead times.

① Special Mounting Angle Specification of Pressure Gauge (45°, 135°, 225°, 315°)

ARG 20 [] [] 01 [] G5 [] [] -X2101 A

Body size

Symbol	Port size
20	1/8
30	3/8
40	1/2

Mounting angle of pressure gauge

Symbol	Description
A	45°
B	135°
C	225°
D	315°

* Refer to the table below.

With back flow mechanism

Symbol	Description
Nil	—
K ⁽¹⁾	With back flow mechanism

Note 1) If the set pressure is not exceeding 0.15 MPa, back flow may not occur. Contact SMC when a back flow mechanism is required with a set pressure of less than 0.15 MPa.

Thread type

Symbol	Type
Nil	Rc
N	NPT
F	G

Port size

Symbol	Port size	Body size		
		20	30	40
01	1/8	●	—	—
02	1/4	●	●	●
03	3/8	—	●	●
04	1/2	—	—	●

Option

Symbol	Description
Nil	—
1 ⁽²⁾	0.02 to 0.2 MPa setting
N	Non-relieving type
Z ⁽³⁾	Name plate and pressure gauge in imperial units (PSI)

* When more than one specification is required, indicate in ascending alphanumeric order.

Note 2) Adjusting spring and pressure gauge (full-span 0.3 MPa) are different from those for the standard specification.

Outlet pressure may increase by 0.2 MPa or more.

Note 3) For thread type NPT
This product is for overseas use only according to the new Measurement Law. (The SI unit type is provided for use in Japan.)

Accessory (2)

Symbol	Description
Nil	—
H	With set nut

Special mounting specification of pressure gauge

Accessory (1)

Symbol	Description
Nil	—
B	With bracket (With nuts)

Mounting Angle of Pressure Gauge

Symbol	X2101A	X2101B	X2101C	X2101D
Mounting angle	45°	135°	225°	315°
Mounting angle view				

⊙: Combination available

■: Combination not available

△: Available only with NP1 thread

Accessory/Optional Combinations

Accessory/Optional specifications	Combination	Symbol	Accessory		Option			Applicable regulator
			B	H	1	N	Z	
With bracket		B	■	■	⊙	⊙	△	⊙
With set nut		H	■	■	⊙	⊙	△	⊙
0.02 to 0.2 MPa setting		-1	⊙	⊙	■	⊙	△	⊙
Non-relieving type		-N	⊙	⊙	⊙	■	△	⊙
Name plate and pressure gauge in imperial units (PSI)		-Z	△	△	△	△	■	△



Series ACG/ARG/AWG Safety Instructions

These safety instructions are intended to prevent a hazardous situation and/or equipment damage. These instructions indicate the level of potential hazard by labels of "**Caution**", "**Warning**" or "**Danger**". To ensure safety, be sure to observe ISO 4414 ^{Note 1)}, JIS B 8370 ^{Note 2)} and other safety practices.

 **Caution** : Operator error could result in injury or equipment damage.

 **Warning** : Operator error could result in serious injury or loss of life.

 **Danger** : In extreme conditions, there is a possible result of serious injury or loss of life.

Note 1) ISO 4414: Pneumatic fluid power--General rules relating to systems.

Note 2) JIS B 8370: General Rules for Pneumatic Equipment

Warning

1. The compatibility of the pneumatic equipment is the responsibility of the person who designs the pneumatic system or decides its specifications.

Since the products specified here are used in various operating conditions, their compatibility for the specific pneumatic system must be based on specifications or post analysis and/or tests to meet your specific requirements. The expected performance and safety assurance are the responsibility of the person who has determined the compatibility of the system. This person should continuously review the suitability of all items specified, referring to the latest catalog information with a view to giving due consideration to any possibility of equipment failure when configuring a system.

2. Only trained personnel should operate pneumatically operated machinery and equipment.

Compressed air can be dangerous if handled incorrectly. Assembly, handling or repair of pneumatic systems should be performed by trained and experienced operators.

3. Do not service machinery/equipment or attempt to remove components until safety is confirmed.

1. Inspection and maintenance of machinery/equipment should only be performed once measures to prevent falling or runaway of the driven objects have been confirmed.
2. When equipment is removed, confirm that safety process as mentioned above. Turn off the supply pressure for this equipment and exhaust all residual compressed air in the system.
3. Before machinery/equipment is restarted, take measures to prevent quick extension of a cylinder piston rod, etc.

4. Contact SMC if the product will be used in any of the following conditions:

1. Conditions and environments beyond the given specifications, or if product is used outdoors.
2. Installation on equipment in conjunction with atomic energy, railway, air navigation, vehicles, medical equipment, food and beverages, recreation equipment, emergency stop circuits, clutch and brake circuits in press applications, or safety equipment.
3. An application which has the possibility of having negative effects on people, property, or animals, requiring special safety analysis.



F.R.L. (Filters/Regulators/Lubricators) Precautions 1

Be sure to read this before handling.

Design

⚠ Warning

1. The standard bowl for the air filter, filter regulator, and lubricator and the pressure gauge cover for the regulator and filter regulator, as well as the sight dome for the lubricator are made of polycarbonate. Do not use in an environment where they are exposed to or come in contact with organic solvents, chemicals, cutting oil, synthetic oil, ester-based compressor oil, alkali, and thread lock solutions.
2. Avoid applications where pressurized air is frequently introduced to and released from the standard bowl of an air filter, filter regulator, or lubricator. It may cause the bowl to be damaged. Use of a metal bowl is recommended for such applications.
3. Consult with SMC if the intended application calls for absolutely zero leakage due to special atmospheric requirements, or if the use of a fluid other than air is required.
4. **Regulator and filter regulator**
Be sure to install a safety device to prevent damage or malfunction of the outlet side components when the output pressure exceeds the set pressure value.

⚠ Caution

1. Select a model that is suitable for the desired purity by referring to the SMC's Best Pneumatics catalog.
2. Components cannot be used for applications that are outside the range of specifications. Consult with SMC when you anticipate using the component outside the range of its specifications (such as temperature and pressure).
3. **Mist separator and micro-mist separator**
Design the system so that the mist separator and micro-mist separator are installed where there is less pulsation. A pressure difference between internal and external pressure inside the element should be kept within 0.1 MPa, as exceeding this value can cause damage.
4. **Regulator and filter regulator**
Air consumption is 0.1 ℓ /min (ANR) or less under standard specifications. Consult with SMC, if this value is not allowable.
5. **Air combination**
 - 1) When using a 2-unit combination such as ACG□0A, ACG□0B, ACG□0D, secure the top and bottom of the bracket. However, when choosing the ACG20B with a downward facing handle, note that it cannot be fixed with brackets in both the upper and lower side. Consult with SMC if you need to fix the product with brackets in both the upper and lower side.
 - 2) The bracket position varies depending on the attachment (pressure switch) mounting.
 - 3) Brackets cannot be mounted on both sides of pressure switch.
 - 4) Contact SMC for changing the bracket mounting position.

Design

⚠ Caution

6. Regarding specific product precautions on air filters, lubricators and mist separators, refer to the catalog, "SMC Best Pneumatics 2004 catalog Vol. 14" or "Precautions for Handling Pneumatic Devices (M-03-E3A)".

Selection

⚠ Warning

1. The mineral grease used on internal sliding parts and seals may run down to outlet side components. Consult with SMC if this is not desirable.
2. **Regulator and filter regulator**
 - 1) Residual pressure release (outlet pressure release) is not complete even by releasing the inlet pressure. To release residual pressure, select a model with a back flow mechanism. Using a model without a back flow mechanism makes for inconsistent residual pressure release (i.e., residual pressure may or may not be released) depending upon the operating conditions.
 - 2) Contact SMC if air will not be consumed in the system for a long period of time, or if the outlet side will be used with a sealed circuit and a balanced circuit, as this may cause the set pressure of the outlet side to fluctuate.
 - 3) Set the regulating pressure range for the outlet pressure of the regulator in a range that is 85% or less of the inlet pressure. If set to above 85%, the outlet pressure will be easily affected by fluctuations in the flow rate and inlet pressure, and become unstable.
 - 4) A safety margin is calculated into the maximum regulating pressure range appearing in the catalog's specification table. However, the pressure settings may exceed the number in the specifications.
 - 5) Contact SMC when a circuit requires the use of a regulator having relief sensitivity with high precision and setting accuracy.
3. **Lubricator**
 - 1) Contact SMC when the lubricator is used in high frequency operations, such as in a press.
 - 2) Lubrication cannot be properly performed if the operating flow rate is too low. Select proper size lubricator by referring the minimum dripping flow rate provided in this catalog.
 - 3) Avoid the use of a lubricator that causes back flow as this may cause damage to internal parts.
 - 4) Use a check valve (Series AKM) to prevent the lubricant from back flowing when branching the piping on the inlet side.



F.R.L. (Filters/Regulators/Lubricators) Precautions 2

Be sure to read this before handling.

Design

Warning

4. Float-type auto-drain

Use auto-drain under the following conditions to avoid malfunction.

<N.O. type>

- Operating compressor: 0.75 kW (100 ℓ/min (ANR)) or more
When using 2 or more auto-drains, multiply the above value by the number of auto-drains to find the capacity of the compressors you will need.

For example, when using 2 auto-drains, the compressor capacity with 1.5 kW (200 ℓ/min (ANR)) or greater is required.

- Operating pressure: 0.1 MPa or more

<N.C. type>

- Operating pressure for AD17/27: 0.1 MPa or more
- Operating pressure for AD37/47: 0.15 MPa or more

Mounting

Caution

1. To avoid reversed connections of the air inlet/outlet, make connections after confirming the "IN/OUT" mark or arrows that indicate the direction of air flow. Reversed connections can cause malfunction.
2. Components with a bowl, e.g., air filter, filter regulator, lubricator, must be installed vertically with the bowl facing downward. Otherwise, faulty drain discharge and dripping cannot be verified.
3. Ensure sufficient top, bottom, and front clearance for maintenance and operation of each component. Refer to the dimensions section for the minimum clearance for each component.
4. **Regulator and filter regulator**
 - 1) Be sure to unlock the handle before adjusting the pressure and to lock it after the pressure is set.
 - 2) During transport and installation, do not apply shock to the product, such as by dropping doing so will affect its precision.
 - 3) Do not install it in an area that is exposed to high temperature or humidity, because doing so will lead to improper operation.

Adjustment

Warning

1. Regulator and filter regulator

- 1) Set the regulator while verifying the displayed values of the inlet and outlet pressure gauges. Turning the handle excessively can cause damage to the internal parts.
- 2) Do not use a tool on the pressure regulator handle as this can cause damage. It must be operated manually.

Caution

1. Regulator and filter regulator

- 1) Check the inlet pressure carefully before setting the product.
- 2) To set the pressure using the handle, turn the handle in the direction that increases pressure and lock the handle after the pressure is set. If this is done in the direction that decreases pressure, the pressure may drop from the original set pressure. Turning the handle clockwise increases the outlet pressure, and turning it counterclockwise reduces the pressure.
- 3) After setting the pressure, there may be an occurrence in which the outlet pressure increases when the inlet pressure is removed and then supplied again. In this case, once the air is consumed at the outlet side, the pressure becomes close to the original set pressure.
- 4) Using a product for a long period of time may fluctuate the outlet pressure. Confirm the set pressure periodically.



F.R.L. (Filters/Regulators/Lubricators) Precautions 3

Be sure to read this before handling.

Piping

⚠ Caution

1. Before piping, it should be thoroughly blown out with air (flushing) or washed to remove chips, cutting oil and other debris from inside the pipe.
2. When screwing piping or fittings into ports, ensure that chips from the pipe threads or sealing material do not get inside the piping. Also, when the pipe tape is used, leave 1.5 to 2 thread ridges exposed at the end of the threads.
3. To screw piping materials into components, tighten with a recommended tightening torque while holding the female thread side. If the minimum tightening torque is not observed, this can cause a looseness and seal failure. On the other hand, excess tightening torque can cause damage to the threads. Furthermore, tightening without holding the female thread side can cause damage due to the excess force that is applied directly to the piping bracket.

Recommended Tightening Torque (N·m)

Connection thread	1/8	1/4	3/8	1/2
Torque	7 to 9	12 to 14	22 to 24	28 to 30

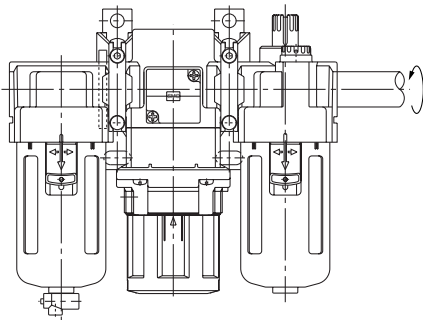

4. Avoid excessive torsional moment or bending moment other than those caused by the equipment's own weight as this can cause damage. Support external piping separately.

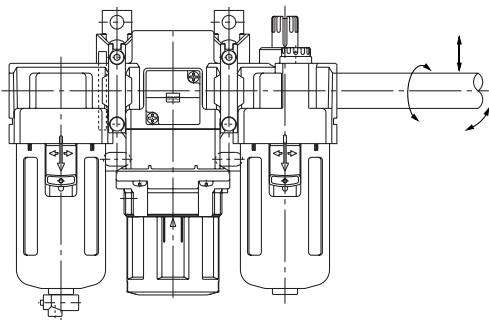

5. Piping materials without flexibility such as steel tube piping are prone to be affected by excess moment load and vibration from the piping side. Use flexible tubing in between to avoid such an effect.
6. Be sure to provide piping for discharging the drainage because there is no valve function equipped with the drain guide. Without piping, drainage or compressed air will be discharged. Also, when performing the piping work, secure the drain guide using a wrench, etc. The case can be damaged if the drain guide is not fixed.

Piping

⚠ Warning

1. Lubricator

Try to avoid riser piping and branch lines as much as possible on the outlet side, otherwise proper lubrication will be compromised.

2. Float type auto-drain

Drain piping should be performed under the following conditions to avoid malfunction.

<N.O. type>

- Use piping whose I.D. is $\phi 6.5$ or larger, and whose length is 5 m or less. Avoid riser piping.

<N.C. type>

- AD27: Use piping whose I.D. is $\phi 2.5$ or larger
AD37/47: Use piping whose I.D. is $\phi 4$ or larger
Length is 5 m or less. Avoid riser piping.

Air Supply

⚠ Caution

1. Use clean air. If chemicals, organic solvents, synthetic oil or corrosive gases are included in the compressed air, parts could be damaged or they can cause a malfunction.
2. When there is excessive condensate, install a device that eliminates water, such as a dryer or water separator (Drain Catch) on the inlet side of the air filter.

Maintenance

⚠ Warning

1. When disassembly or installation is required during the maintenance, repair, or replacement of a device, be sure to follow the instructions provided in the instruction manual or safety instructions in this catalog.
2. Perform periodical inspections to detect any cracks, scratches, or other deterioration of the transparent resin bowl of the air filter, filter regulator, and lubricator or the sight dome of the lubricator.
Replace with a new bowl, sight dome, or metal bowl when any kind of deterioration is found, otherwise this can cause damage.
3. Perform periodical inspections to detect dirt on the transparent resin bowl of the air filter, filter regulator, and lubricator or the sight dome of the lubricator or the pressure gauge cover of regulator and filter regulator. When you find dirt on any of the above devices, clean with a mild household cleanser. Do not use other cleaning agents, otherwise this can cause damage.
4. Manually open or close the drain cock of air filters, filter regulators and lubricators. Using tools can cause the product to be damaged.
5. Air filter
 - 1) Replace the element every 2 years or when the pressure drop becomes 0.1 MPa, whichever comes first, to prevent damage to the element.
 - 2) Release accumulated condensate periodically before it reaches the maximum capacity. Condensate that flows out to the outlet side can cause malfunctions.



F.R.L. (Filters/Regulators/Lubricators) Precautions 4

Be sure to read this before handling.

Maintenance

Warning

1 Lubricator

Use class 1 turbine oil (without additives) ISO VG32. Using other lubricant can cause damage to devices and result in malfunctions.

Caution

1 Perform periodical inspections of the filter element and replace it as necessary. Check the element whenever the outlet pressure drops below normal or air does not flow smoothly during operation.

2 Regulator and filter regulator

Check the sliding part or seat of the internal valve when a setting malfunction or relief leakage occur and temporary or emergency repairs need to be made.

3 Lubricator

Check the dripping amount once a day. Drip failure can cause damage to the components being lubricated.

4. Float type auto-drain

- 1 Turn the handle counterclockwise to release the drain manually. Avoid applying excessive torque to the handle, such as by using a tool, as this can damage an auto-drain. After releasing the condensate, turn the handle clockwise until it stops.
- 2) Air leakage or other performance malfunctions can occur if premature clogging of the element or pressure drop causes the pressure inside the bowl to get outside the specified pressure range parameters. Check the pressure whenever such an irregularity occurs.



Series ACG/ARG/AWG

Specific Product Precautions

Be sure to read this before handling.

Procedure for replacing or changing the mounting angle of a pressure gauge

Warning

When replacing a pressure gauge and/or changing the mounting angle, release the inlet and outlet pressure completely. It is dangerous to replace the pressure gauge or change the mounting angle while it is under pressure.

1. Advance preparation

Keep the handle unlocked and completely loosened. The unlocked condition of the handle can be visually confirmed by the "Orange line" shown near the bottom of the handle.



2. Removing the handle

To remove the handle, align the ▼ mark on the handle and the ▲ mark on the bonnet and then pull the handle.

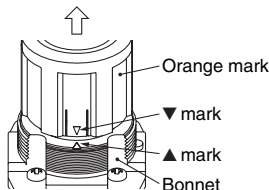

3. Removing the clip

When the ▲ mark on the bonnet and the ▼ mark on the pressure regulator guide are aligned, the clip can be seen from the side view of the bonnet. The clip can be picked and removed with tweezers.

* When adjusting the mark, turn the pressure regulator guide clockwise for adjustment.

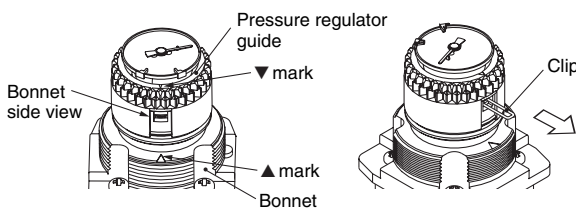

4. Removing the pressure gauge

Pull the pressure gauge out by holding the outer edge of the dial.

* Do not touch the internal mechanical portion (shown inside the dotted box). Accuracy of the pressure gauge may be adversely affected.

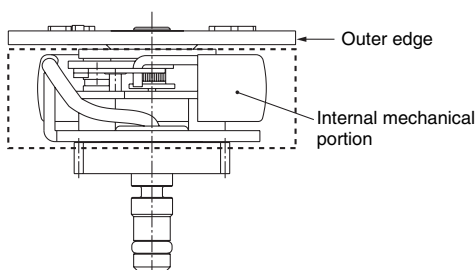

5. Setting the pressure gauge

After the mounting angle is adjusted as required, hold the outer edge of the pressure gauge dial and gently press down. For reference, the required clearance between the bottom of the dial and the top of the pressure regulator guide is shown in table 1.

Note 1) When the pressure gauge cannot be easily positioned, slightly rotate it. (The cog from the planet gear of the pressure regulator guide may be caught vertically in the cog from the sun gear which is mounted and integrated with the pressure gauge)

Note 2) Position the pressure gauge to the very bottom.

Note 3) Attached to the tip of the pressure gauge is an O-ring with grease applied to it. Please use caution to prevent particles and/or dust from entering the pressure gauge when it is set. Otherwise, they may cause air leakage.

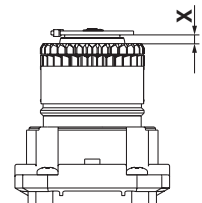

Table 1. Clearance Dimensions

	ARG20 AWG20	ARG30 AWG30	ARG40 AWG40
X dimension (reference value)	2.6 mm	3.3 mm	3.3 mm

6. Setting the clip

Insert the clip in the side of the bonnet when the ▼ mark on the pressure regulator guide and the ▲ mark on the bonnet are aligned. When inserting and setting the clip, use an instrument with a narrow tip, such as tweezers.

Note 1) The clip is slightly tapered towards its tip to prevent it from being released. Set the clip by slightly opening its tip.

Note 2) When the clip cannot easily be set, the cause may be as follows:

(1) The pressure regulator screw might have been in a lower position than then the current one. (The pressure regulator screw may reach a lower position if the pressing force of the pressure regulator screw is excessively applied. This occurs because there is a clearance between the pressure regulator nut and pressure spring, when the pressure regulator screw is loosened completely.)

(2) The pressure gauge is not firmly set.
Countermeasures Refer to 5 "Setting the pressure gauge".

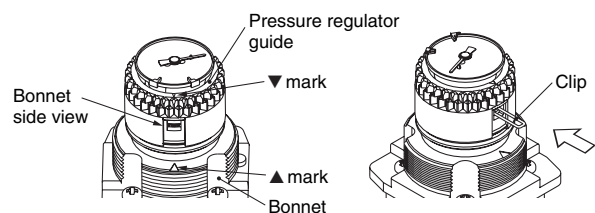

7. Setting the handle

Finished when the handle is set.



SMC'S GLOBAL MANUFACTURING, DISTRIBUTION AND SERVICE NETWORK

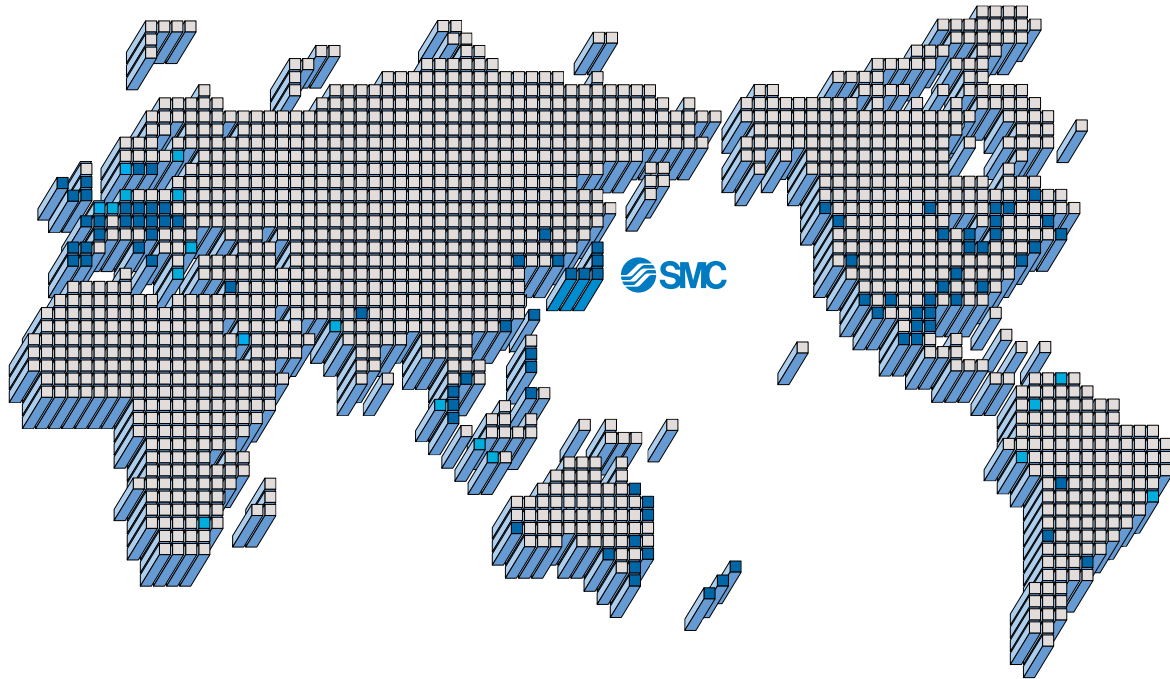

EUROPE

AUSTRIA

SMC Pneumatik GmbH

BELGIUM

SMC Pneumatics N.V./S.A.

BULGARIA

SMC Industrial Automation Bulgaria EOOD

CROATIA

SMC Industrijska automatika d.o.o.

CZECH REPUBLIC

SMC Industrial Automation CZ s.r.o.

DENMARK

SMC Pneumatik A/S

ESTONIA

SMC Pneumatics Estonia OÜ

FINLAND

SMC Pneumatics Finland OY

FRANCE

SMC Pneumatique SA

GERMANY

SMC Pneumatik GmbH

HUNGARY

SMC Hungary Ipari Automatizálási Kft.

IRELAND

SMC Pneumatics (Ireland) Ltd.

ITALY

SMC Italia S.p.A.

LATVIA

SMC Pnuematics Latvia SIA

NETHERLANDS

SMC Pneumatics BV

NORWAY

SMC Pneumatics Norway A/S

POLAND

SMC Industrial Automation Polska Sp.z.o.o.

ROMANIA

SMC Romania s.r.l.

RUSSIA

SMC Pneumatik LLC.

SLOVAKIA

SMC Priemyselná automatizácia, s.r.o.

SLOVENIA

SMC INDUSTRIJSKA AVTOMATIKA d.o.o.

SPAIN/PORTUGAL

SMC España, S.A.

SWEDEN

SMC Pneumatics Sweden AB

SWITZERLAND

SMC Pneumatik AG

UK

SMC Pneumatics (U.K.) Ltd.

ASIA

CHINA

SMC (China) Co., Ltd.

HONG KONG

SMC Pneumatics (Hong Kong) Ltd

INDIA

SMC Pneumatics (India) Pvt. Ltd.

INDONESIA

PT SMC Pneumatics Indonesia

MALAYSIA

SMC Pneumatics (S.E.A.) Sdn. Bhd.

PHILIPPINES

SHOKETSU-SMC Corporation

SINGAPORE

SMC Pneumatics (S.E.A.) Pte. Ltd.

SOUTH KOREA

SMC Pneumatics Korea Co., Ltd.

TAIWAN

SMC Pneumatics (Taiwan) Co., Ltd

THAILAND

SMC Thailand Ltd.

NORTH AMERICA

CANADA

SMC Pneumatics (Canada) Ltd.

MEXICO

SMC Corporation (Mexico) S.A. de C.V.

USA

SMC Corporation of America

SOUTH AMERICA

ARGENTINA

SMC Argentina S.A.

BOLIVIA

SMC Pneumatics Bolivia S.R.L.

BRAZIL

SMC Pneumaticos Do Brazil Ltda.

CHILE

SMC Pneumatics (Chile) S.A.

VENEZUELA

SMC Neumatica Venezuela S.A.

OCEANIA

AUSTRALIA

SMC Pneumatics (Australia) Pty Ltd.

NEW ZEALAND

SMC Pneumatics (N.Z.) Ltd.



Safety Instructions

Be sure to read "Precautions for Handling Pneumatic Devices" (M-03-E3A) before using.

SMC Corporation

1-16-4 Shimbashi, Minato-ku, Tokyo 105-8659 JAPAN

Tel: 03-3502-2740 Fax: 03-3508-2480

URL <http://www.smcworld.com>

© 2005 SMC Corporation All Rights Reserved

Specifications are subject to change without prior notice and any obligation on the part of the manufacturer.

D-DN

1st printing JR printing JR 120DN Printed in Japan.

This catalog is printed on recycled paper with concern for the global environment.