

Basic type / Direct mount type

Series *CY3B/CY3R*

ø6, ø10, ø15, ø20, ø25, ø32, ø40, ø50, ø63



CY3B
CY3R

CY1S

CY1L

CY1H

CY1F

CYP

D-□

-X□

Individual
-X□

Technical
data

Series *CY3B/CY3R*

Improved durability

Improved bearing performance

A 70% longer wear ring length achieving an improvement in bearing performance compared to the CY1B.

Improved lubrication by using a lubretainer

A special resin lubretainer is installed on the dust seal to achieve ideal lubrication on the external surface of the cylinder tube.

Direct mount type *Series CY3R*



Basic type *Series CY3B*



Series Variations

Series	Bore size	Standard stroke (mm)											Individual made-to-order products						
		50	100	150	200	250	300	350	400	450	500	600	700	800	900	1000			
CY3B	ø6	●																Heat resistant specifications (XB6)	
	ø10	●	●	●	●	●	●	●	●	●	●	●	●	●	●	●	●	Low speed specifications (15 to 50 mm/s) (XB9)	
	ø15	●	●	●	●	●	●	●	●	●	●	●	●	●	●	●	●	Long stroke (XB11)	
	ø20	●	●	●	●	●	●	●	●	●	●	●	●	●	●	●	●	Low speed specifications (7 to 50 mm/s) (XB13)	
	ø25	●	●	●	●	●	●	●	●	●	●	●	●	●	●	●	●	Hydro specifications (X116)	
	ø32	●	●	●	●	●	●	●	●	●	●	●	●	●	●	●	●	Axial ports (X132)	
	ø40	●	●	●	●	●	●	●	●	●	●	●	●	●	●	●	●	High speed specifications (X160)	
	ø50	●	●	●	●	●	●	●	●	●	●	●	●	●	●	●	●	Helical insert thread specifications (X168)	
CY3R	ø6	●																Added mounting tap positions for slider (X206)	
	ø10	●	●	●	●	●	●	●	●	●	●	●	●	●	●	●	●	Oil-free exterior specifications (X210)	
	ø15	●	●	●	●	●	●	●	●	●	●	●	●	●	●	●	●	Outside of cylinder tube with hard chrome plating (X322)	
	ø20	●	●	●	●	●	●	●	●	●	●	●	●	●	●	●	●	Oil-free exterior specifications (with dust seal) (X324)	
	ø25	●	●	●	●	●	●	●	●	●	●	●	●	●	●	●	●	Interchangeable specification with CY1□6 (X1468)	
	ø32	●	●	●	●	●	●	●	●	●	●	●	●	●	●	●	●	With magnetic shielding plate (XC24)	
	ø40	●	●	●	●	●	●	●	●	●	●	●	●	●	●	●	●	With floating joint (XC57)	
	ø50	●	●	●	●	●	●	●	●	●	●	●	●	●	●	●	●		
ø63	●	●	●	●	●	●	●	●	●	●	●	●	●	●	●	●			

Note) The ● mark indicates the available combination of bore size and standard stroke.

Availability of made to order products varies with the series and the bore size. For more information, please refer to pages 1395 to 1565.

Upgraded version of space saving magnetically rodless cylinder!

Reduction of sliding resistance

Minimum operating pressure reduced by 30%

By using a lubretainer, the minimum operating pressure is reduced by 30%.

(CY3B40 compared with CY1B40)

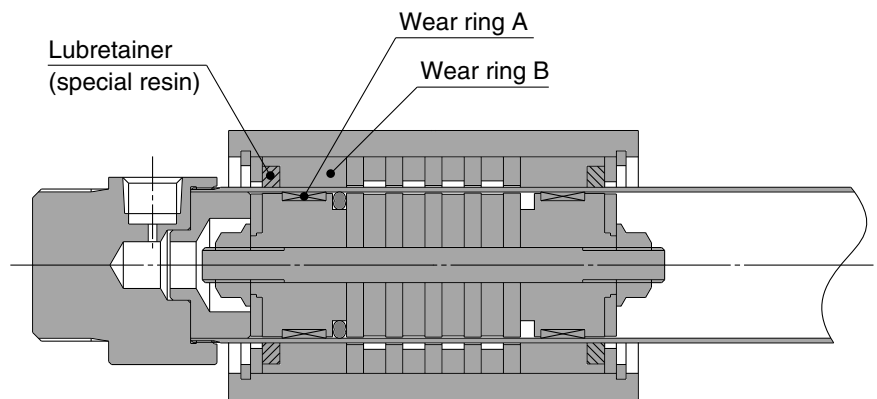

■ Series CY3B ■

CY3B
CY3R

CY1S

CY1L

CY1H

CY1F

CYP

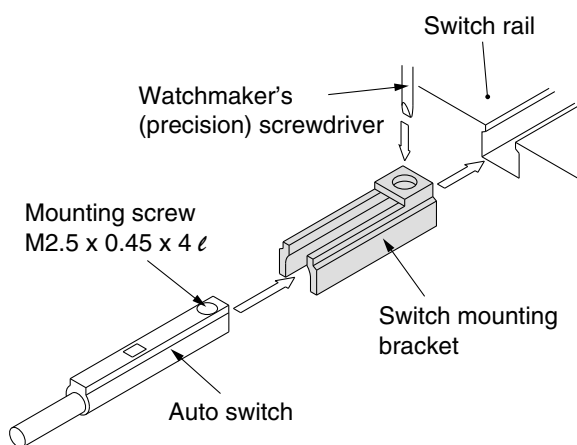

Small auto switches are mountable.

Small auto switches can be mounted on the current auto switch mounting groove of the CY3R25 to 63. So, they can be mounted to all of the cylinder sizes in the CY3R series, making inventory control of the product easy.

Lightweight

The body weight has been reduced by approximately 10% by eliminating unnecessary body weight and by reducing the outer diameter of the cylinder tube. (Compared with previous $\phi 50$ and $\phi 60$ models)

D-□

-X□

Individual
-X□

Technical
data

Series CY3B/CY3R

Model Selection 1

E: Kinetic energy of load (J)

$$E = \frac{(W + W_B)}{2} \times \left(\frac{V}{1000}\right)^2$$

Es: Allowable kinetic energy for intermediate stop using an air pressure circuit (J)

Fn: Allowable driving force (N)

Mb: Maximum allowable moment (N-m) when a connection bracket, etc. is carried directly

Ps: Operating pressure limit for intermediate stop using an external stopper, etc. (MPa)

Pv: Maximum operating pressure for vertical operation (MPa)

Wbmax: Maximum load mass (kg) when loaded directly on the body

Wv: Allowable load mass for vertical operation (kg)

Operating Conditions

- W: Load mass (kg)
- W_B: Connection bracket mass (kg)
- μ: Guide's coefficient of friction
- L_o: Distance from cylinder shaft center to workpiece point of application (cm)
- L₁: Distance from cylinder shaft center to connection fitting, etc. (mm)
- Switches
- P: Operating pressure (MPa)
- V: Speed (mm/s)
- Stroke (mm)
- Mode of operation (horizontal, inclined, vertical)

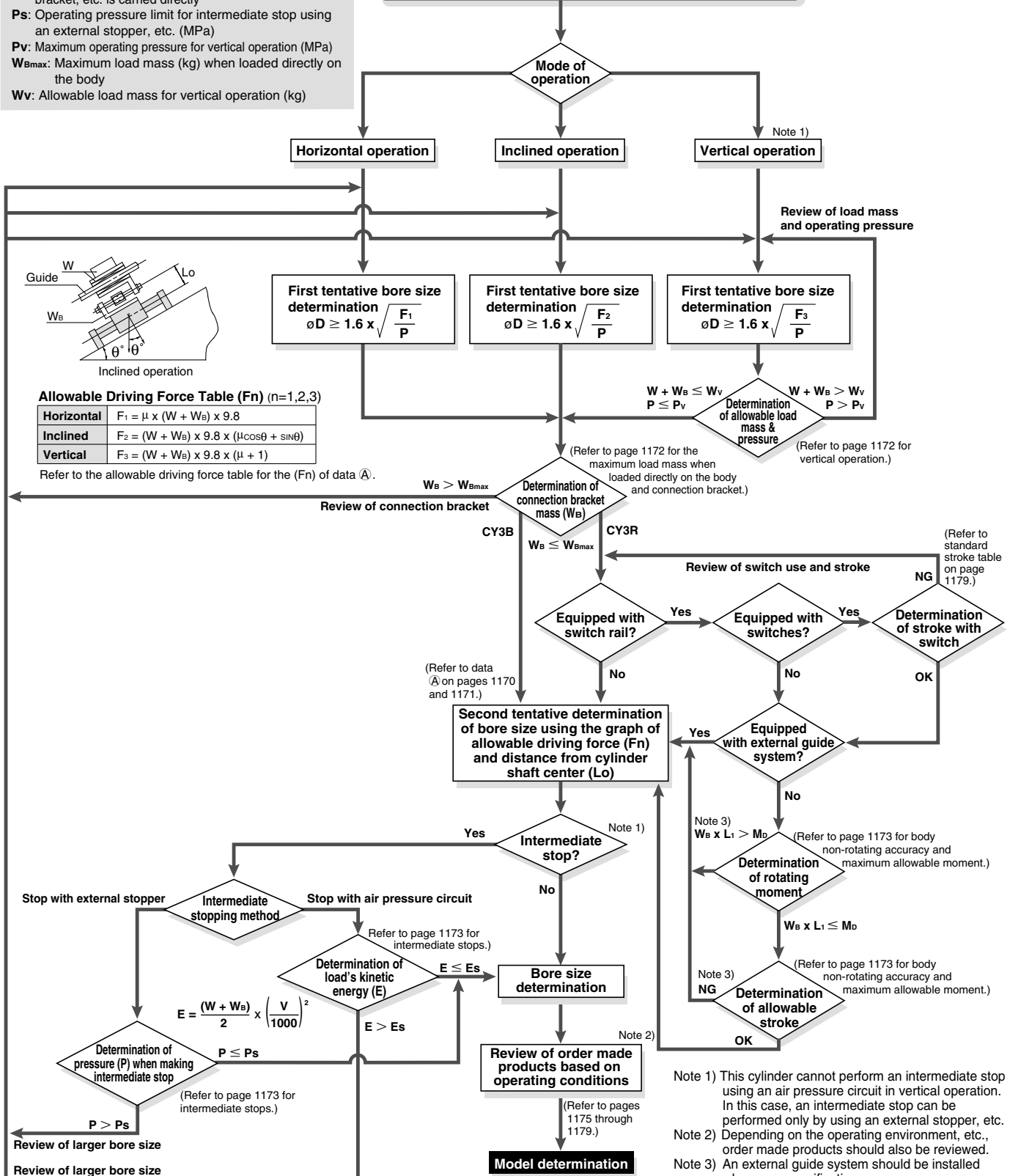

- CY3B
- CY3R
- CY1S
- CY1L
- CY1H
- CY1F
- CYP

- D-□
- X□
- Individual
- X□
- Technical data

Note 1) This cylinder cannot perform an intermediate stop using an air pressure circuit in vertical operation. In this case, an intermediate stop can be performed only by using an external stopper, etc.

Note 2) Depending on the operating environment, etc., order made products should also be reviewed.

Note 3) An external guide system should be installed when over specifications.

Series CY3B/CY3R

Model Selection 2

Precautions on Design 1

Selection Procedure

Selection procedure

1. Find the drive resisting force F_n (N) when moving the load horizontally.
2. Find the distance L_o (cm) from the point of the load where driving force is applied, to the center of the cylinder shaft.
3. Select the bore size from L_o and F_n , based on data (A).

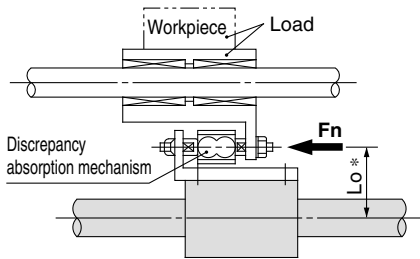

Selection example

Given a load drive resisting force of $F_n = 100$ (N) and a distance from the cylinder shaft center to the load application point of $L_o = 8$ cm, find the intersection point by extending upward from the horizontal axis of data (A) where the distance from the shaft center is 8 cm, and then extending to the side, find the allowable driving force on the vertical axis.

Models suitable in satisfying the requirement of 100 (N) are **CY3□32** or **CY3□40**.

* The L_o point from the cylinder shaft center is the moment working point between the cylinder and the load section.

<Data (A): Distance from cylinder shaft center — Allowable driving capacity>

CY3B6

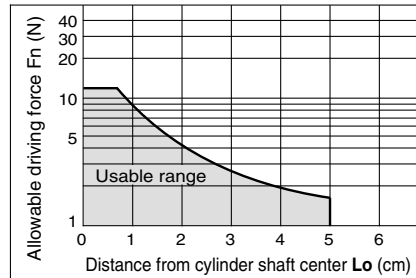

CY3B32

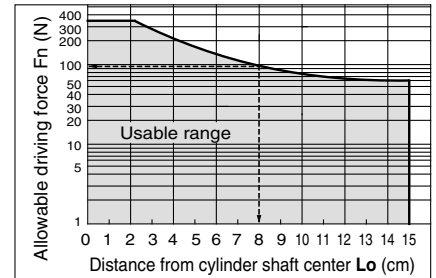

CY3B10

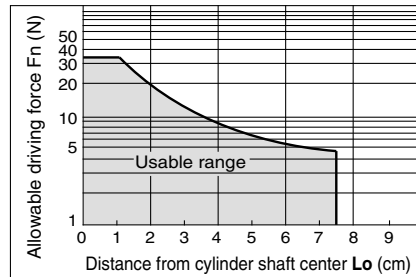

CY3B40

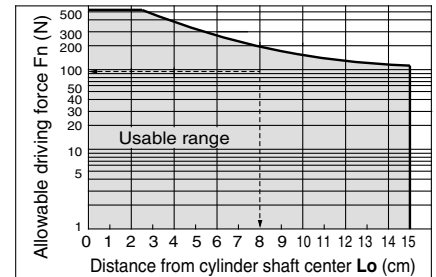

CY3B15

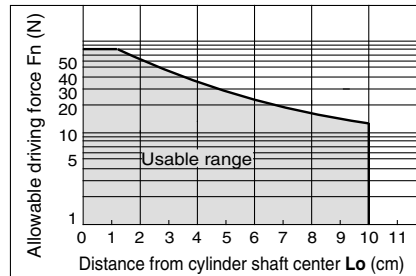

CY3B50

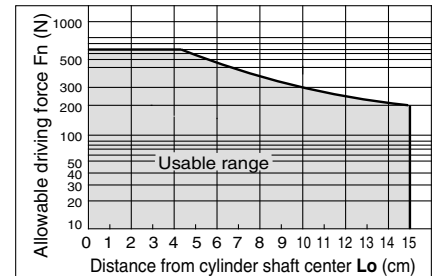

CY3B20

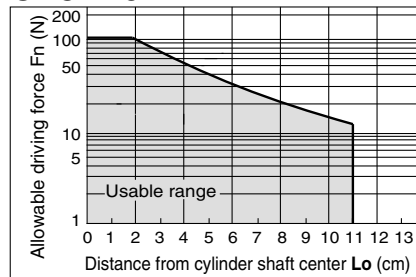

CY3B63

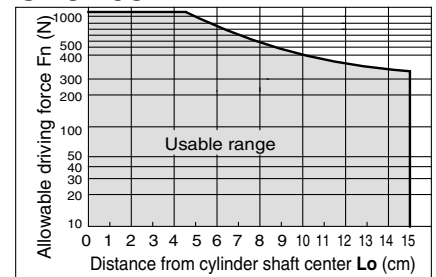

CY3B25

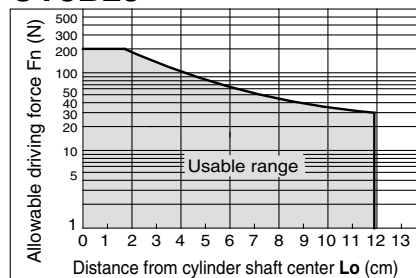

Precautions on Design 1

<Data (A) : Distance from cylinder shaft center — Allowable driving capacity>

CY3R6

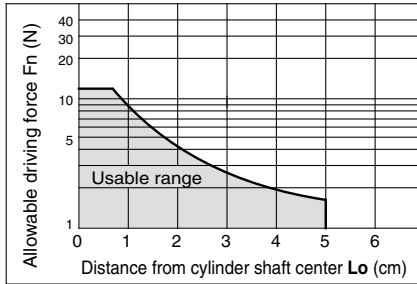

CY3R32

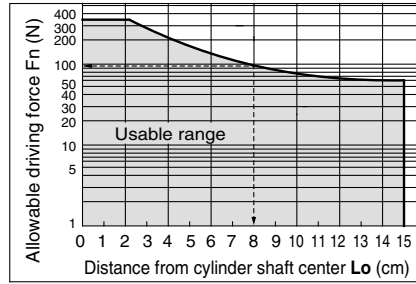

CY3R10

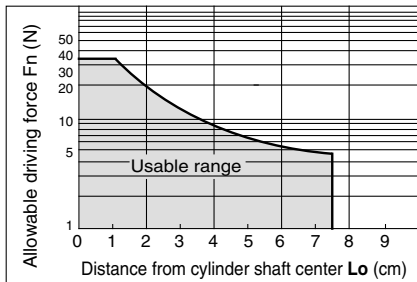

CY3R40

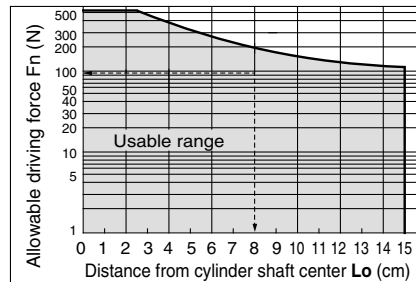

CY3R15

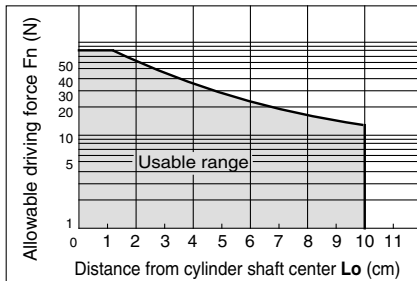

CY3R50

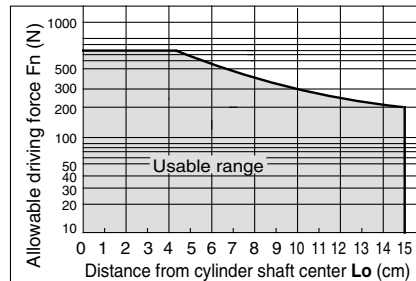

CY3R20

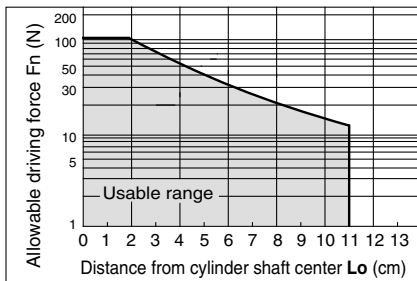

CY3R63

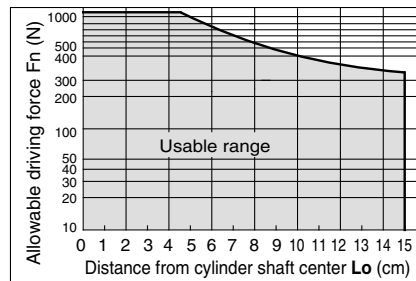

CY3R25

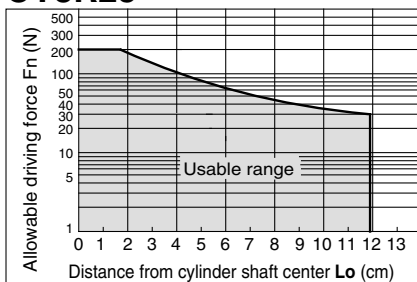

CY3B
CY3R

CY1S

CY1L

CY1H

CY1F

CYP

D-□

-X□

Individual

-X□

Technical
data

Series CY3B/CY3R

Model Selection 3

Precautions on Design 2

Cylinder Dead Weight Deflection

When the cylinder is mounted horizontally, deflection appears due to its own weight as shown in the data, and the longer the stroke is, the greater the amount of variation in the shaft center. Therefore, a connection method should be considered which can assimilate this deflection.

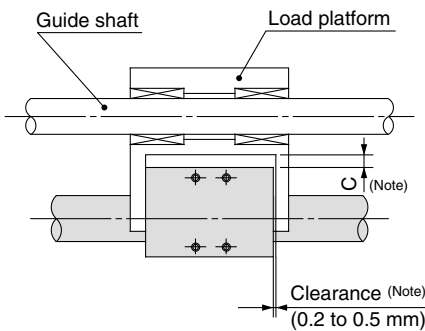

The above clearance amount is a reference value.

Note 1) According to the dead weight deflection in the figure on the right, provide clearance so that the cylinder does not touch the mounting surface or the load, etc., and is able to operate smoothly within the minimum operating pressure range for a full stroke. For more information, refer to instruction manual.

Note 2) In case of the CY3R, install a shim, etc. to eliminate clearance between the body and the switch rail. For more information, refer to the CY3R instruction manual.

Note 3) The amount of deflection differs from the CY1B/CY1R. Adjust the clearance value by referring to the dead weight deflection as shown in the table on the right.

When CY1B/CY1R are replaced with CY3B/CY3R, install a cylinder after confirming a full stroke and clearance are allowed.

Vertical Operation

It is recommended that the load is guided by a ball type bearing (linear guide, etc.). If a slide bearing is used, sliding resistance increases due to the load mass and moment, which may cause malfunctions.

When the cylinder is mounted vertically or sidelong, a slider may move downwards due to the self-weight or workpiece mass. If an accurate stopping position is required at the stroke end or mid-stroke, use an external stopper to secure accurate positioning.

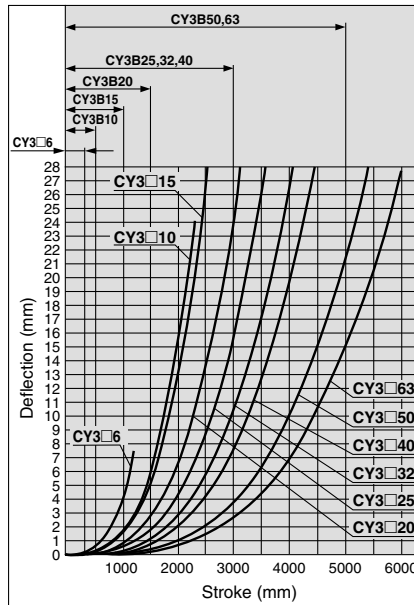
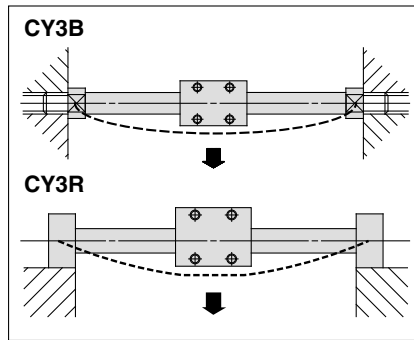
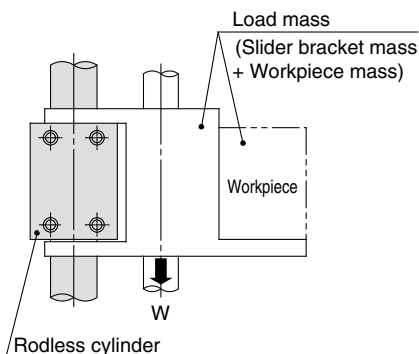

* The above deflection data represent values at the time when the external sliding part moves to the middle of the stroke.

Maximum Mass of Connection Bracket to the Body

Series CY3B is guided by an external axis (such as a linear guide) without directly mounting the load. When designing a metal bracket to connect the load, make sure that its weight will not exceed the value in the table below. Basically, guide the CY3R direct mounting type also with an external axis. (For connection methods, refer to the Instruction Manual.)

Max. Connection Bracket Mass

Model	Max. connection bracket mass (W _{max}) (kg)
CY3□6	0.2
CY3□10	0.4
CY3□15	1.0
CY3□20	1.1
CY3□25	1.2
CY3□32	1.5
CY3□40	2.0
CY3□50	2.5
CY3□63	3.0

Consult with SMC in case a bracket with mass exceeding the above value is to be mounted.

<CY3R>

Maximum Load Mass when Loaded Directly on Body

When the load is applied directly to the body, it should be no greater than the maximum values shown in the table below.

Model	Max. load weight (W _{max}) (kg)
CY3R6	0.2
CY3R10	0.4
CY3R15	1.0
CY3R20	1.1
CY3R25	1.2
CY3R32	1.5
CY3R40	2.0
CY3R50	2.5
CY3R63	3.0

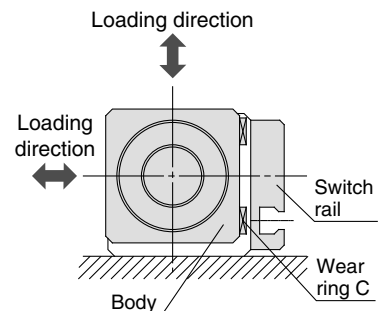

Bore size (mm)	Model	Allowable load mass (W _v) (kg)	Max. operating pressure (P _v) (MPa)
6	CY3□6	1.0	0.55
10	CY3□10	2.7	0.55
15	CY3□15	7.0	0.65
20	CY3□20	11.0	0.65
25	CY3□25	18.5	0.65
32	CY3□32	30.0	0.65
40	CY3□40	47.0	0.65
50	CY3□50	75.0	0.65
63	CY3□63	115.0	0.65

* Use caution, as there is a danger of breaking the magnetic coupling if operated above the maximum operating pressure.

Precautions on Design 3

Intermediate Stop

(1) Intermediate stopping of load with an external stopper, etc.

When stopping a load in mid-stroke using an external stopper, etc., operate within the operating pressure limits shown in the table below. Use caution, as operation at a pressure exceeding these limits can result in breaking of the magnetic coupling.

Bore size (mm)	Model	Operating pressure limit for intermediate stop (Ps) (MPa)
6	CY3□6	0.55
10	CY3□10	0.55
15	CY3□15	0.65
20	CY3□20	0.65
25	CY3□25	0.65
32	CY3□32	0.65
40	CY3□40	0.65
50	CY3□50	0.65
63	CY3□63	0.65

(2) Intermediate stopping of load with an air pressure circuit

When performing an intermediate stop of a load using an air pressure circuit, operate at or below the kinetic energy shown in the table below. Use caution, as operation when exceeding the allowable value can result in breaking of the magnetic coupling.

(Reference values)

Bore size (mm)	Model	Allowable kinetic energy for intermediate stop (Es) (J)
6	CY3□6	0.007
10	CY3□10	0.03
15	CY3□15	0.13
20	CY3□20	0.24
25	CY3□25	0.45
32	CY3□32	0.88
40	CY3□40	1.53
50	CY3□50	3.12
63	CY3□63	5.07

Stroke End Stopping Method

When stopping a load having a large inertial force at the stroke end, tilting of the body and damage to the bearings and cylinder tube may occur. (Refer to the left hand drawing below.)

As shown in the right hand drawing below, a shock absorber should be used together with the stopper, and thrust should also be transmitted from the center of the body so that tilting will not occur.

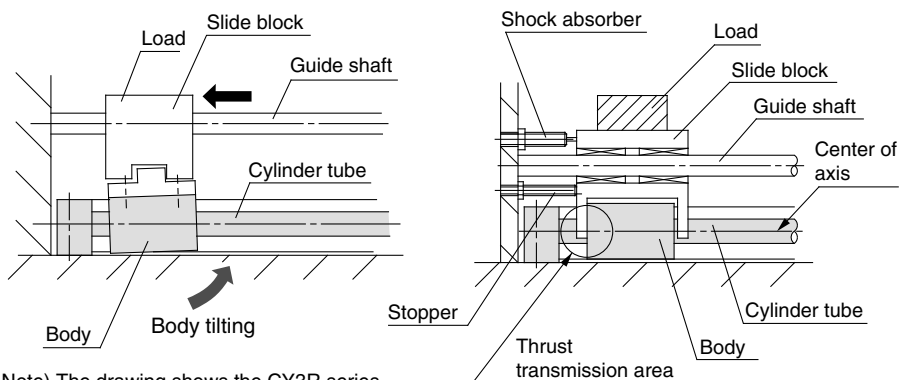

Note) The drawing shows the CY3R series.

<CY3R>

Body Non-rotating Accuracy and Maximum Allowable Moment (with Switch Rail)

(Reference values)

Reference values for non-rotating accuracy and maximum allowable moment at stroke end are indicated below.

Bore size (mm)	Non-rotating accuracy (°)	Max. allowable moment (M ₀) (N·m)	Allowable stroke (mm)
6	7.3	0.02	100
10	6.0	0.05	100
15	4.5	0.15	200
20	3.7	0.20	300
25	3.7	0.25	300
32	3.1	0.40	400
40	2.8	0.62	400
50	2.4	1.00	500
63	2.2	1.37	500

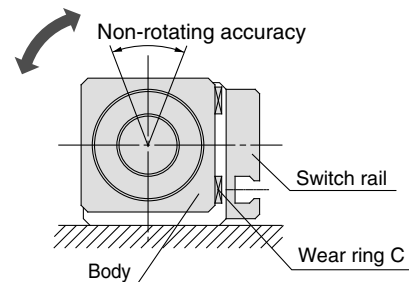

Note 1) Avoid operations where rotational torque (moment) is applied. In such a case, the use of an external guide is recommended.

Note 2) The above reference values will be satisfied within the allowable stroke ranges, but caution is necessary, because as the stroke becomes longer, the inclination (rotation angle) within the stroke can be expected to increase.

Note 3) When a load is applied directly to the body, the loaded weight should be no greater than the allowable load mass on page 1172.

CY3B
CY3R

CY1S

CY1L

CY1H

CY1F

CYP

D-□

-X□

Individual
-X□

Technical
data

Magnetically Coupled Rodless Cylinder/ Basic Type

Series **CY3B**

ø6, ø10, ø15, ø20, ø25, ø32, ø40, ø50, ø63

How to Order

Basic type **CY3B** **25** - **300** -

Basic type

Bore size

6	6mm
10	10mm
15	15mm
20	20mm
25	25mm
32	32mm
40	40mm
50	50mm
63	63mm

Standard stroke
Refer to the standard stroke table shown below.

Made to Order
Refer to page 1175 for details.

Port thread type

Symbol	Type	Bore size
Nil	M thread	6, 10, 15
	Rc	20, 25, 32, 40
TN	NPT	50, 63
TF	G	

Standard Stroke

Bore size (mm)	Standard stroke (mm)	Maximum available stroke (mm)
6	50, 100, 150, 200	300
10	50, 100, 150, 200, 250, 300	500
15	50, 100, 150, 200, 250, 300, 350, 400, 450, 500	1000
20	100, 150, 200, 250, 300, 350, 400, 450, 500, 600, 700, 800	1500
25		3000
32		3000
40	100, 150, 200, 250, 300, 350, 400, 450, 500, 600, 700, 800, 900, 1000	3000
50		5000
63		5000

Note 1) Long stroke specification (XB11) applies to the strokes exceeding 2000 mm. (Refer to page 1405.)

Note 2) The longer the stroke, the larger the amount of deflection in a cylinder tube. Pay attention to the mounting bracket and clearance value.

Note 3) Intermediate stroke is available by the 1 mm interval.

Magnetically Coupled Rodless Cylinder Basic Type **Series CY3B**

Specifications



JIS Symbol

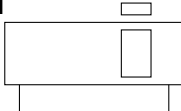

Made to Order
(Refer to pages 1395 to 1565 for details.)

Symbol	Specifications
-XB6	Head resistant cylinder (-10 to 150°C)
-XB9	Low-speed cylinder (15 to 50mm/s)
-XB11	Long stroke type
-XB13	Low-speed cylinder (7 to 50mm/s)
-XC24	With magnetic shielding plate
-XC57	With floating joint
-X116	Hydro specifications
-X132	Axial ports
-X160	High speed specifications
-X168	Helical insert thread specifications
-X206	Added mounting tap positions for slider
-X210	Non-lubricated exterior specifications
-X322	Outside of cylinder tube with hard chrome plating
-X324	Non-lubricated exterior specifications (with dust seal)
-X1468	Interchangeable specification with CY1□6

Bore size (mm)	6	10	15	20	25	32	40	50	63
Fluid	Air								
Proof pressure	1.05 MPa								
Max. operating pressure	0.7 MPa								
Min. operating pressure	0.16	0.16	0.16	0.16	0.15	0.14	0.12	0.12	0.12
Ambient and fluid temperature	-10 to 60°C								
Piston speed	50 to 500 mm/s								
Cushion	Rubber bumper								
Lubrication	Not required (Non-lube)								
Stroke length tolerance	0 to 250 st: $+1.0_0$, 251 to 1000 st: $+1.4_0$, 1001 st to: $+1.8_0$								
Mounting orientation	Horizontal, Inclined, Vertical (Note)								
Mounting nut (2 pcs.)	Standard equipment (accessory)								
Magnet holding force (N)	19.6	53.9	137	231	363	588	922	1471	2256

Note) When vertically mounting, it is impossible to perform an intermediate stop by means of a pneumatic circuit.

Theoretical Cylinder Thrust

Caution When calculating the actual thrust, design should consider the minimum actuating pressure.

ø6, ø10

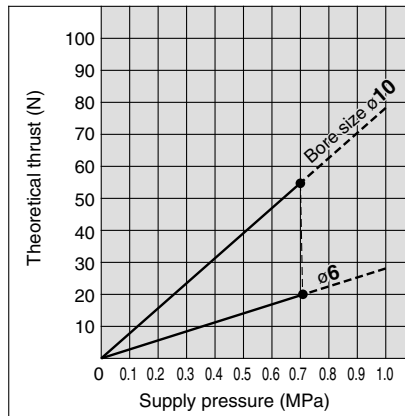

ø15, ø20, ø25, ø32, ø40

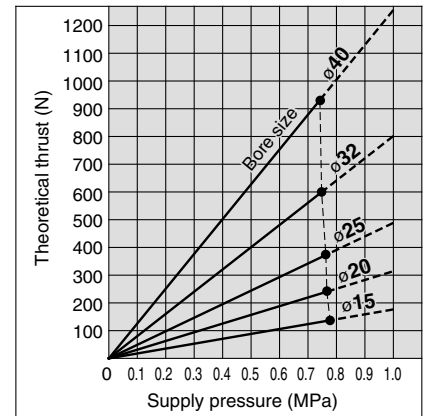

ø50, ø63

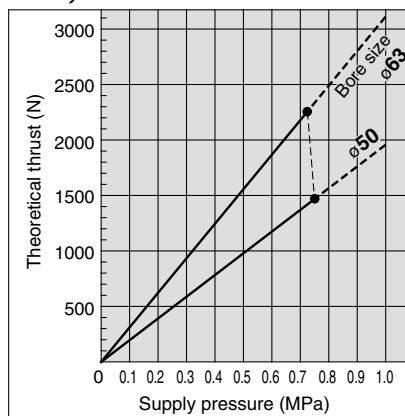

Mass

Unit: kg

Bore size (mm)	6	10	15	20	25	32	40	50	63
Basic mass (at 0 st)	0.052	0.08	0.275	0.351	0.672	1.287	2.07	3.2	5.3
Additional mass per 50 mm of stroke	0.004	0.014	0.015	0.02	0.023	0.033	0.04	0.077	0.096

Calculation method/Example: **CY3B32-500**

Basic mass 1.287 kg
 Additional mass 0.033/50 st
 Cylinder stroke 500 st
 } 1.287 + 0.033 x 500 ÷ 50 = 1.617 kg



CY3B
CY3R

CY1S

CY1L

CY1H

CY1F

CYP

D-□

-X□

Individual

-X□

Technical

data

Series CY3B

Construction

Basic type CY3B6

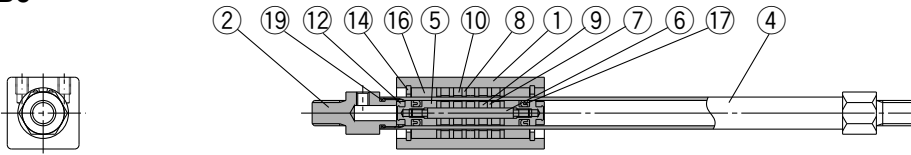

CY3B10, 15

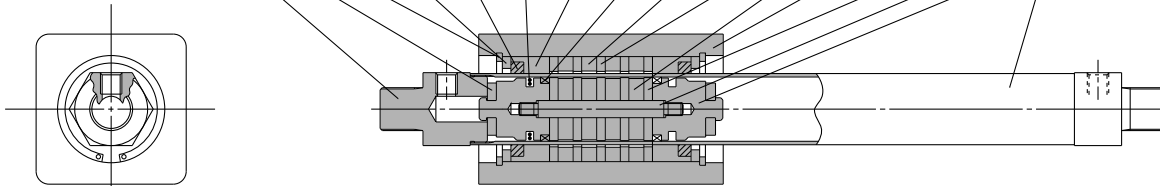

* The above drawing is $\phi 15$. (3 magnets are used in $\phi 10$.)

CY3B20 to 40

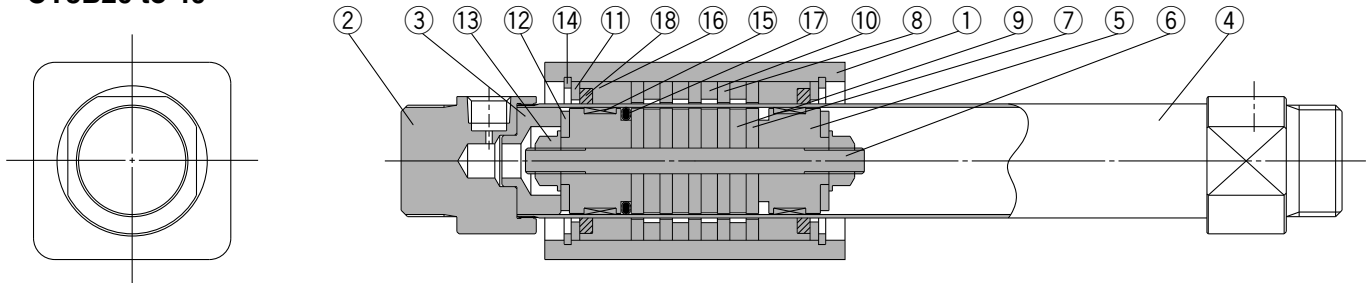

CY3B50, 63

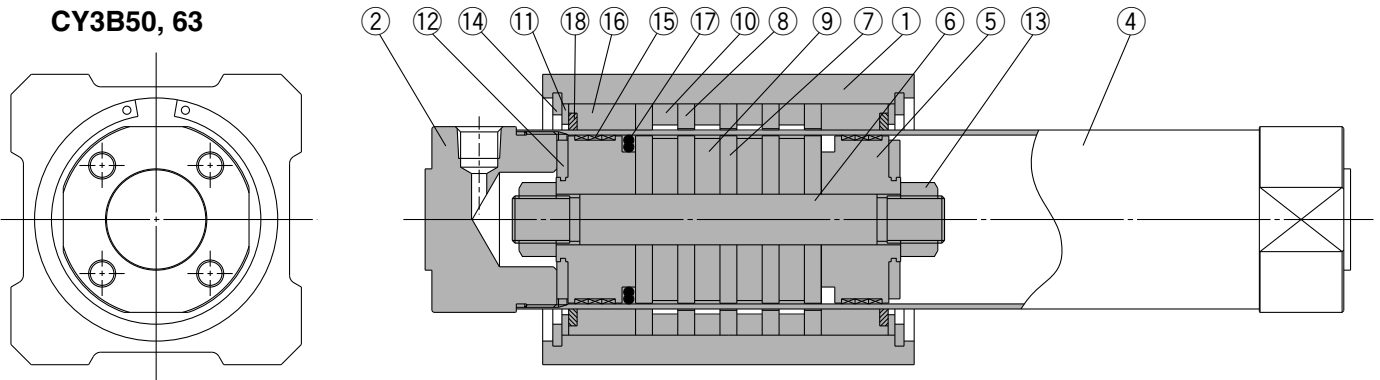

Component Parts

No.	Description	Material	Note
1	Body	Aluminum alloy	Hard anodized
2	Head cover	$\phi 6, \phi 10$ Brass	
		$\phi 15$ to $\phi 63$ Aluminum alloy	
3	End collar	Aluminum alloy	$\phi 20$ to $\phi 40$ only
4	Cylinder tube	Stainless steel	
5	Piston	$\phi 6$ to $\phi 15$ Brass	$\phi 6$ to $\phi 15$ Electroless Ni plated
		$\phi 20$ to $\phi 63$ Aluminum alloy	$\phi 20$ to $\phi 63$ Chromated
6	Shaft	Stainless steel	
7	Piston side yoke	Rolled steel	Zinc chromated
8	External slider side yoke	Rolled steel	Zinc chromated
9	Magnet A	—	
10	Magnet B	—	
11	Spacer	Aluminum alloy	$\phi 6$: not available
12	Bumper	Urethane rubber	
13	Piston nut	Carbon steel	$\phi 6$ to $\phi 15$: not available
14	C type retaining ring for hole	Carbon tool steel	Nickel plated
15	Wear ring A	Special resin	
16	Wear ring B	Special resin	
17	Piston seal	NBR	
18	Lubretainer	Special resin	$\phi 6$: not available
19	Cylinder tube gasket	NBR	$\phi 6, \phi 10$ only

Replacement Parts/Seal Kit

Bore size (mm)	Kit no.	Contents
6	CY3B6-PS	Set of nos. above 15, 16, 17, 19
10	CY3B10-PS	Set of nos. above 15, 16, 17, 18, 19
15	CY3B15-PS	Set of nos. above 15, 16, 17, 18
20	CY3B20-PS	
25	CY3B25-PS	
32	CY3B32-PS	
40	CY3B40-PS	
50	CY3B50-PS	
63	CY3B63-PS	

Note 1) Seal kits are sets consisting of numbers 15 through 19. Order using the kit number corresponding to each bore size.

Note 2) Adhesive glue is applied to the thread fixed section of the head cover and cylinder tube. Contact SMC if the head cover removal is difficult.

* Seal kit includes a grease pack ($\phi 6, \phi 10$: 5 g and 10 g, $\phi 15$ to $\phi 63$: 10 g). Order with the following part number when only the grease pack is needed.

Grease pack part number for $\phi 6, \phi 10$: GR-F-005 (5 g) For external sliding sections

GR-S-010 (10 g) For tubing interior

Grease pack part number for $\phi 15$ to $\phi 63$: GR-S-010 (10 g)

Dimensions

Basic type

CY3B6 to 63

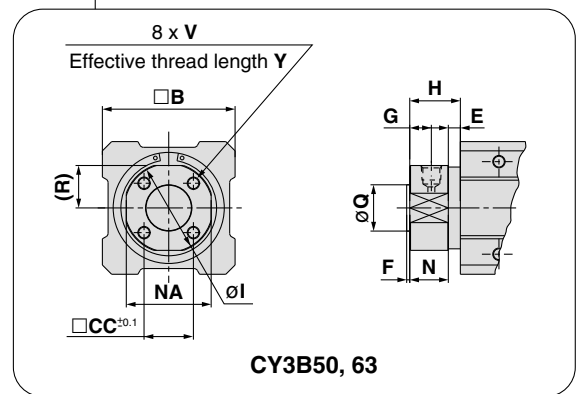
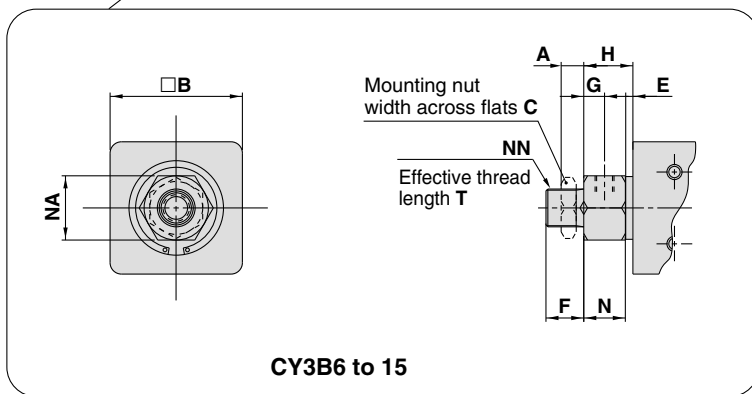
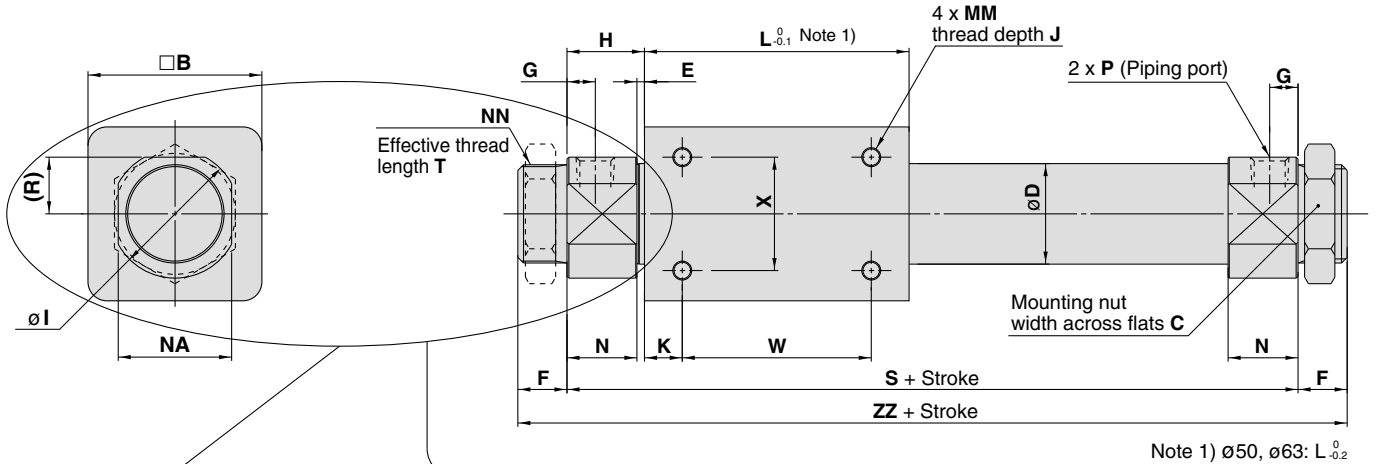

Model	A	B	C	CC	D	E	F	G	H	I	J	K	L	MM	N	NA	NN	Q	R	S	T	V
CY3B6	4	17	8*	—	7.6	4	8*	5	13.5*	—	4.5	5	35	M3 x 0.5	9.5*	10*	M6 x 1*	—	—	62*	6.5	—
CY3B10	4	25	14	—	12	1.5	9	5	12.5	—	4.5	4	38	M3 x 0.5	11	14	M10 x 1	—	—	63	7.5	—
CY3B15	4	35	14	—	16.6*	2	10	5.5	13	—	6	11	57	M4 x 0.7	11	17	M10 x 1	—	—	83	8	—
CY3B20	8	36	26	—	21.6*	2*	13	7.5*	20	28	6	8	66	M4 x 0.7	18*	24	M20 x 1.5	—	12*	106	10	—
CY3B25	8	46	32	—	26.4*	2*	13	7.5*	20.5	34	8	10	70	M5 x 0.8	18.5*	30	M26 x 1.5	—	15*	111	10	—
CY3B32	8	60	32	—	33.6*	2*	16	8*	22	40	8	15	80	M6 x 1	20*	36	M26 x 1.5	—	18*	124	13	—
CY3B40	10	70	41	—	41.6*	3*	16	11	29	50	10	16	92	M6 x 1	26*	46	M32 x 2	—	23*	150	13	—
CY3B50	—	86	—	32	52.4*	8	2	14	33	58*	12	25	110	M8 x 1.25	25	55	—	30 ^{-0.007/-0.037}	27.5*	176	—	M8 x 1.25
CY3B63	—	100	—	38	65.4*	8	2	14	33	72*	12	26	122	M8 x 1.25	25	69	—	32 ^{-0.007/-0.043}	34.5*	188	—	M10 x 1.5

Model	W	X	Y	ZZ	P (Piping port)		
					Nil	TN*	TF*
CY3B6	25	10	—	78*	M3 x 0.5*	—	—
CY3B10	30	16	—	81	M5 x 0.8	—	—
CY3B15	35	19	—	103	M5 x 0.8	—	—
CY3B20	50	25	—	132	Rc 1/8	NPT 1/8	G 1/8
CY3B25	50	30	—	137	Rc 1/8	NPT 1/8	G 1/8
CY3B32	50	40	—	156	Rc 1/8	NPT 1/8	G 1/8
CY3B40	60	40	—	182	Rc 1/4	NPT 1/4	G 1/4
CY3B50	60	60	16	180	Rc 1/4	NPT 1/4	G 1/4
CY3B63	70	70	16	192	Rc 1/4	NPT 1/4	G 1/4

Note 2) The astrisk denotes the dimensions which are different from the CY1B series.

Note 3) Mounting nuts can be screwed on only for the effective thread length of the head cover (T dimension). When mounting a cylinder, consider the thickness of flange, etc.

Mounting Nut/Included in the package (2 pcs).

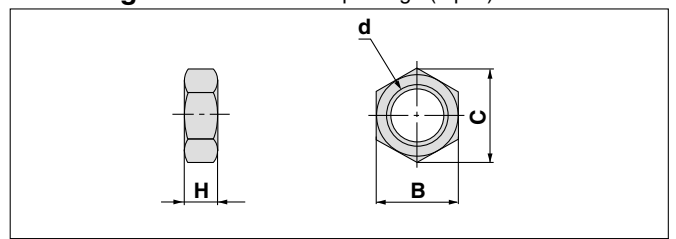

Part no.	Applicable bore size (mm)	d	H	B	C
SNJ-006B	6	M6 x 1.0	4	8	9.2
SNJ-016B	10, 15	M10 x 1.0	4	14	16.2
SN-020B	20	M20 x 1.5	8	26	30
SN-032B	25, 32	M26 x 1.5	8	32	37
SN-040B	40	M32 x 2.0	10	41	47.3

Note) Mounting nuts are not available for $\phi 50$ and $\phi 63$.

- CY3B**
- CY3R**
- CY1S**
- CY1L**
- CY1H**
- CY1F**
- CYP**

- D-□**
- X□**
- Individual
- X□**
- Technical data

Magnetically Coupled Rodless Cylinder/ Direct Mount Type

Series **CY3R**

ø6, ø10, ø15, ø20, ø25, ø32, ø40, ø50, ø63

How to Order

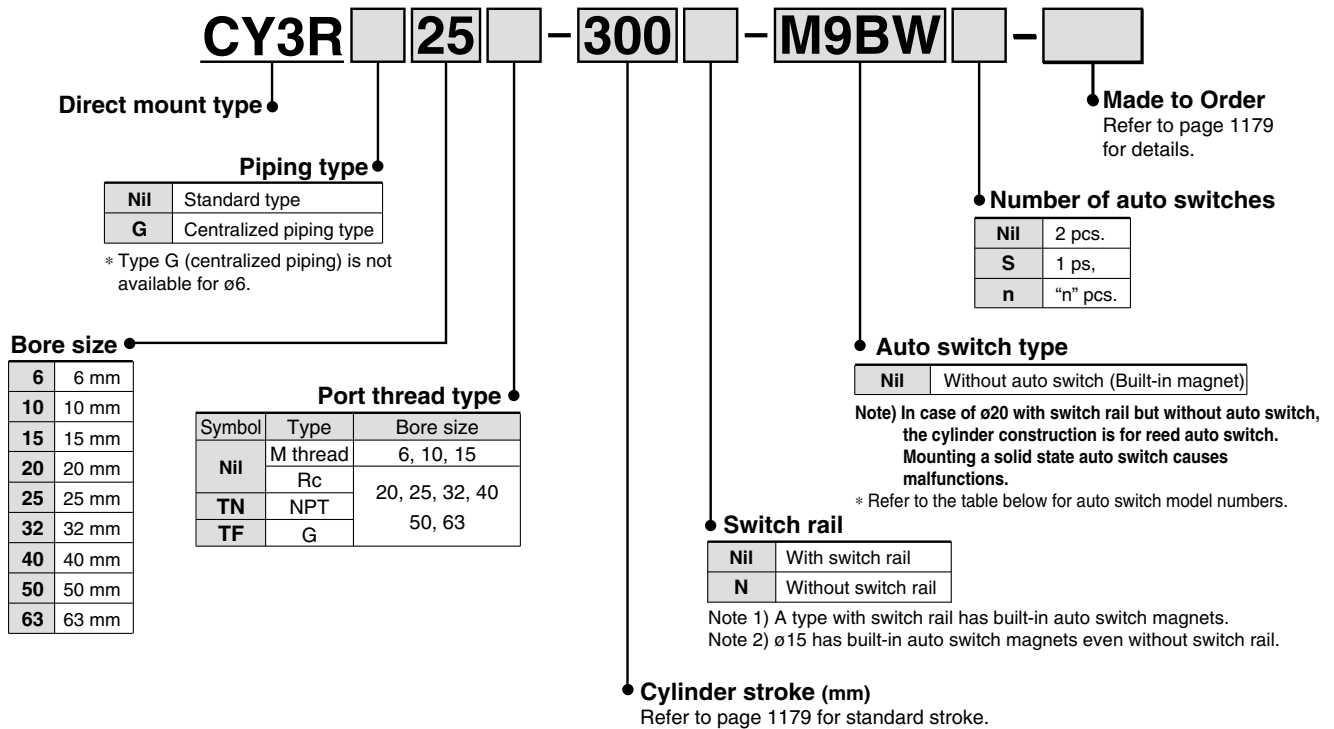

Applicable Auto Switches / Refer to pages 1263 to 1371 for further information on auto switches.

Type	Special function	Electrical entry	Indicator light	Wiring (output)	Load voltage		Auto switch model	Lead wire length (m)				Pre-wired connector	Applicable load										
					DC	AC		0.5 (Nil)	1 (M)	3 (L)	5 (Z)												
Solid state switch	Diagnostic indication (2-color display)	Grommet	Yes	3-wire (NPN)	24V	5V, 12V	—	M9N	●	●	●	○	○	IC circuit									
				3-wire (PNP)				M9P	●	●	●	○	○										
				2-wire				M9B	●	●	●	○	○		—								
				Reed switch				—	Grommet	Yes	3-wire (NPN equiv.)	24V	5V, 12V	100V 100V or less	A96	●	—	●	—	—	IC circuit	—	
											2-wire				A93	●	—	●	—	—	—	—	Relay, PLC
															A90	●	—	●	—	—	—	—	IC circuit

* Lead wire length symbols: 0.5 m Nil (Example) M9NW
1 m M (Example) M9NWM
3 m L (Example) M9NWL
5 m Z (Example) M9NWZ

* Solid state auto switches marked "○" are produced upon receipt of order.

* Other than the applicable auto switches listed in "How to Order", the other auto switches can be mounted. For detailed specifications, refer to page 1185.
* With pre-wired connector is also available in solid state auto switches. For specifications, refer to pages 1328 to 1329.
* The auto switch is shipped together, but not assembled.

Magnetically Coupled Rodless Cylinder Direct Mount Type **Series CY3R**

Specifications



Bore size (mm)	6	10	15	20	25	32	40	50	63
Fluid	Air								
Proof pressure	1.05 MPa								
Max. operating pressure	0.7 MPa								
Min. operating pressure	0.16	0.16	0.16	0.16	0.15	0.14	0.12	0.12	0.12
Ambient and fluid temperature	-10 to 60°C								
Piston speed	50 to 500 mm/s								
Cushion	Rubber bumper								
Lubrication	Not required (Non-lube)								
Stroke length tolerance	0 to 250 st: $+1.0_0$, 251 to 1000 st: $+1.4_0$, 1001 st to: $+1.8_0$								
Mounting	Direct mount type								
Mounting orientation	Horizontal, Inclined, Vertical ^{Note 2)}								
Magnet holding force (N)	19.6	53.9	137	231	363	588	922	1471	2256

Note 1) When an auto switch is installed at an intermediate position of a type with auto switch, keep the maximum piston speed at 300 mm/s or below to ensure operation of relays or other devices.

Note 2) When vertically mounting, it is impossible to perform an intermediate stop by means of a pneumatic circuit.



Made to Order
(Refer to pages 1395 to 1565 for details.)

Symbol	Specifications
-X116	Hydro specifications
-X160	High speed specifications
-X322	Outside of cylinder tube with hard chrome plating
-X1468	Interchangeable specification with CY1□6
-XC57	With floating joint

Standard Stroke

Bore size (mm)	Standard stroke (mm)	Max. stroke without switch (mm)	Max. stroke with switch (mm)
6	50, 100, 150, 200	300	300
10	50, 100, 150, 200, 250, 300	500	500
15	50, 100, 150, 200, 250, 300 350, 400, 450, 500	1000	750
20	100, 150, 200, 250, 300, 350 400, 450, 500, 600, 700, 800	1500	1000
25			1200
32	100, 150, 200, 250, 300, 350 400, 450, 500, 600, 700, 800 900, 1000	2000	1500
40			
50			
63			

Note 1) The longer the stroke, the larger the amount of deflection in a cylinder tube. Pay attention to the mounting bracket and clearance value.

Note 2) Intermediate stroke is available by the 1 mm interval.

Theoretical Cylinder Thrust



When calculating the actual thrust, design should consider the minimum actuating pressure.

ø6, ø10

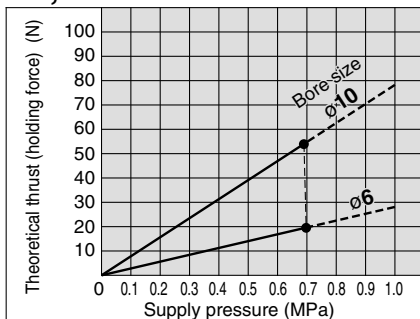

ø15, ø20, ø25, ø32, ø40

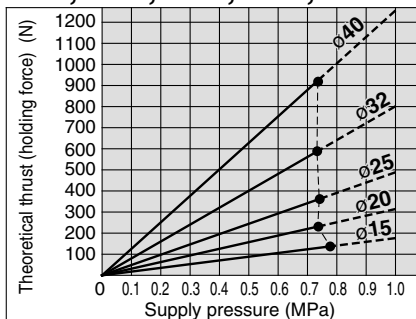

ø50, ø63

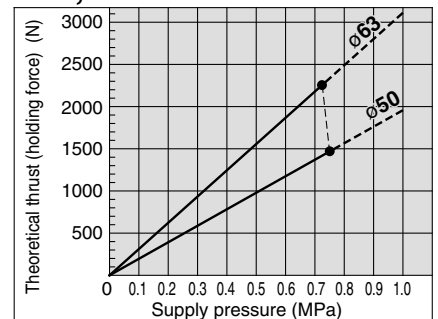

Mass

Unit: kg

Bore size (mm)		6	10	15	20	25	32	40	50	63
Basic mass (at 0 st)	With switch rail	0.086	0.111	0.272	0.421	0.622	1.217	1.98	3.54	5.38
	Without switch rail	0.069	0.08	0.225	0.351	0.542	1.097	1.82	3.25	5.03
Additional mass per 50 mm of stroke	With switch rail	0.016	0.034	0.040	0.051	0.056	0.076	0.093	0.159	0.188
	Without switch rail	0.004	0.014	0.015	0.020	0.023	0.033	0.040	0.077	0.096

Calculation method/Example: **CY3R25-500** (with switch rail) Basic mass...0.622 (kg), Additional mass...0.056 (kg/50 st), Cylinder stroke...500 (st)
 $0.622 + 0.056 \times 500 \div 50 = 1.182$ (kg)

CY3B
CY3R

CY1S

CY1L

CY1H

CY1F

CYP

D-□

-X□

Individual
-X□

Technical
data

Series CY3R

Construction

Both sides piping type

CY3R6

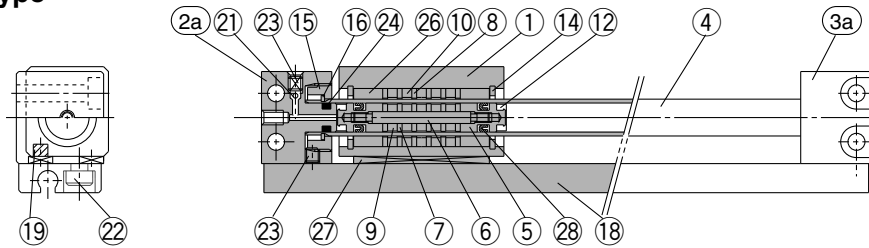

CY3R10

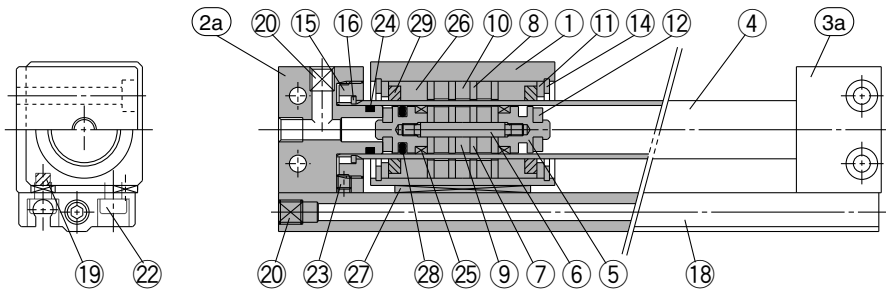

CY3R15 to 63

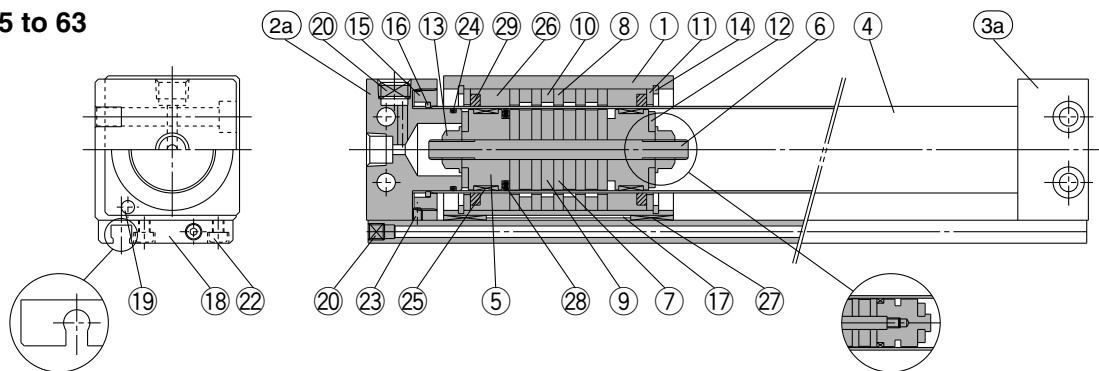

CY3R15, 20

CY3R15

Component Parts

No.	Description	Material	Note								
1	Body	Aluminum alloy	Hard anodized								
2a	End cover A	Aluminum alloy									
2b	End cover C	Aluminum alloy									
3a	End cover B	Aluminum alloy									
3b	End cover D	Aluminum alloy									
4	Cylinder tube	Stainless steel									
5	Piston	<table border="1"> <tr> <td>ø6 to ø15</td> <td>Brass</td> <td>ø6 to ø15</td> <td>Electroless nickel plated</td> </tr> <tr> <td>ø20 to ø63</td> <td>Aluminum alloy</td> <td>ø20 to ø63</td> <td>Chromate</td> </tr> </table>	ø6 to ø15	Brass	ø6 to ø15	Electroless nickel plated	ø20 to ø63	Aluminum alloy	ø20 to ø63	Chromate	
ø6 to ø15	Brass	ø6 to ø15	Electroless nickel plated								
ø20 to ø63	Aluminum alloy	ø20 to ø63	Chromate								
6	Shaft	Stainless steel									
7	Piston side yoke	Rolled steel plate	Zinc chromated								
8	External slider side yoke	Rolled steel plate	Zinc chromated								
9	Magnet A	—									
10	Magnet B	—									
11	Spacer	Aluminum alloy	ø6: not available								
12	Bumper	Urethane rubber									
13	Piston nut	Carbon steel	Zinc chromate (ø6 to ø15: not available)								
14	Type C retaining ring for hole	Carbon tool steel	Nickel plated								
15	Attachment ring	Aluminum alloy	Chromate								
16	Type C retaining ring for shaft	Hard steel wire									
17	Magnetic shielding plate	Rolled steel plate	Chromated (ø6, ø10: not available)								
18	Switch rail	Aluminum alloy	White anodized								
19	Magnet	—									
20	Hexagon socket head plug	Chromium steel	Nickel plated								
21	Steel balls	Chromium steel	<table border="1"> <tr> <td>ø40</td> <td>Hexagon socket head plug</td> </tr> <tr> <td>ø20, ø50, ø63</td> <td>None</td> </tr> </table>	ø40	Hexagon socket head plug	ø20, ø50, ø63	None				
ø40	Hexagon socket head plug										
ø20, ø50, ø63	None										
22	Hexagon socket head screw	Chromium steel									
23	Hexagon socket head set screw	Chromium steel	Nickel plated								
24 ^{Note2)}	Cylinder tube Gasket	NBR									

No.	Description	Material	Note
25 ^{Note2)}	Wear ring A	Special resin	
26 ^{Note2)}	Wear ring B	Special resin	
27 ^{Note2)}	Wear ring C	Special resin	
28 ^{Note2)}	Piston seal	NBR	
29 ^{Note2)}	Lubretainer	Special resin	
30 ^{Note2)}	Switch rail gasket	NBR	Both sides piping type: None

Replacement Parts/Seal Kit

Bore size (mm)	Kit no.	Contents
6	CY3R6-PS	Set of nos. above 24, 26, 27, 28
10	CY3R10-PS	
15	CY3R15-PS	
20	CY3R20-PS	
25	CY3R25-PS	Set of nos. above 24, 25, 26, 27, 28, 29, 30
32	CY3R32-PS	
40	CY3R40-PS	
50	CY3R50-PS	
63	CY3R63-PS	

Note1) Seal kits are the same for both the both sides piping type and the centralized piping type.

Note2) Seal kits are sets consisting of numbers 24 through 30. Order using the kit number corresponding to each bore size.

* Seal kit includes a grease pack (ø6, ø10: 5 and 10 g, ø15 to ø63: 10 g). Order with the following part number when only the grease pack is needed.

Grease pack part number for ø6, ø10: GR-F-005 (5 g) For external sliding sections
GR-S-010 (10 g) For tubing interior

Grease pack part number for ø15 to ø63: GR-S-010 (10 g)

Construction

Centralized piping type

CY3RG10

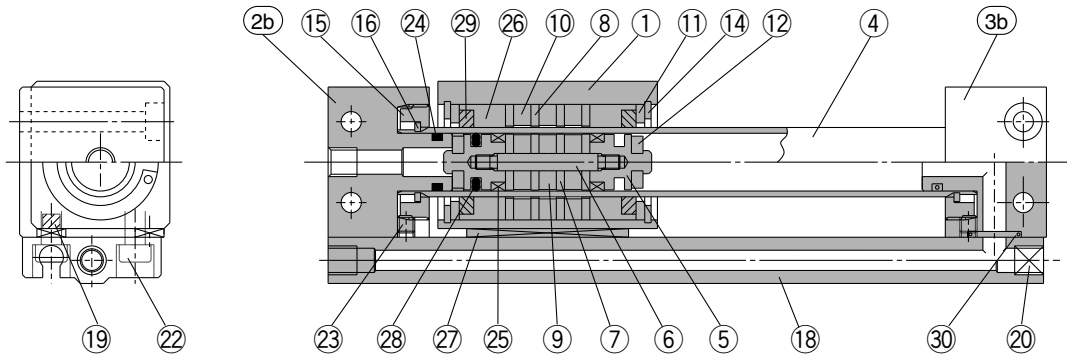

CY3RG15 to 63

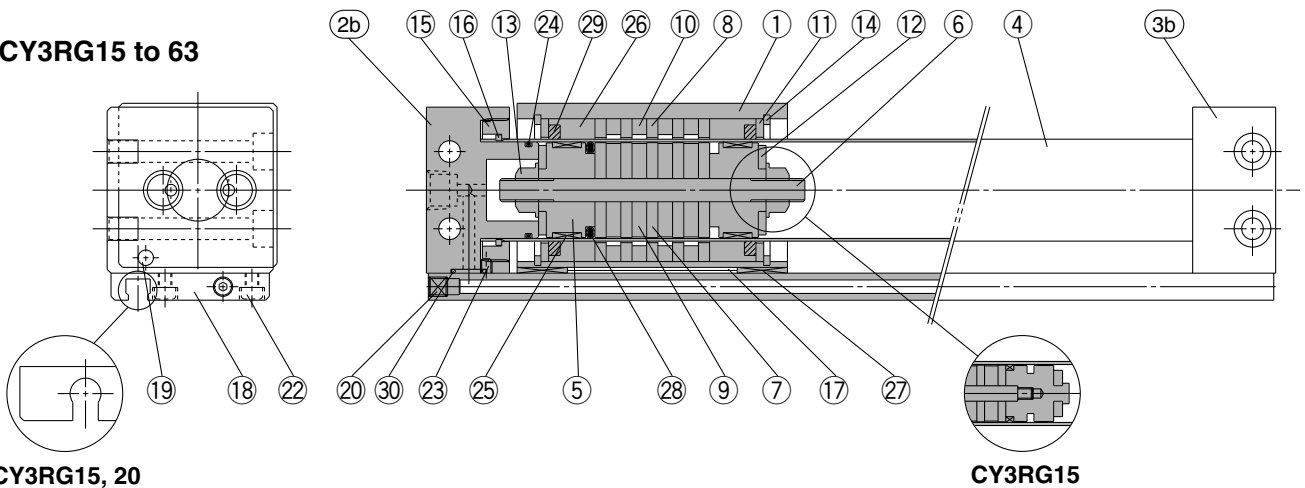

CY3RG15, 20

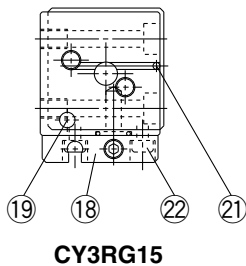

CY3RG15

CY3B
CY3R

CY1S

CY1L

CY1H

CY1F

CYP

Switch Rail Accessory

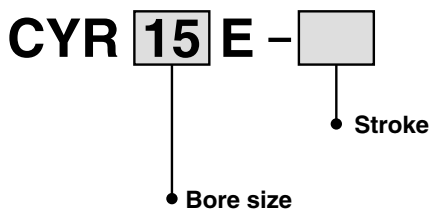

Switch Rail Accessory Kit

Bore size (mm)	Kit no.	Contents
6	CYR6E-□-N	Numbers 18, 19, 22, 27 on the left
10	CYR10E-□	Numbers 18, 19, 20, 22, 27 on the left
15	CYR15E-□	Numbers 17, 18, 20, 22, 27 on the left <small>Note 2)</small>
20	For reed switch CYR20E-□	Numbers 17, 18, 19, 20, 22, 27 on the left
	For solid state switch CYR20EN-□	
25	CYR25E-□	Numbers 17, 18, 19, 20, 22, 27 on the left
32	CYR32E-□	
40	CYR40E-□	
50	CYR50E-□	
63	CYR63E-□	

Note 1) □ indicates the stroke.

Note 2) A magnet is already built in for ø15.

D-□

-X□

Individual
-X□

Technical
data

Series CY3R

Dimensions

Both sides piping type: $\varnothing 6$ to $\varnothing 63$

Note) This figure shows types with switch rail (Nil).

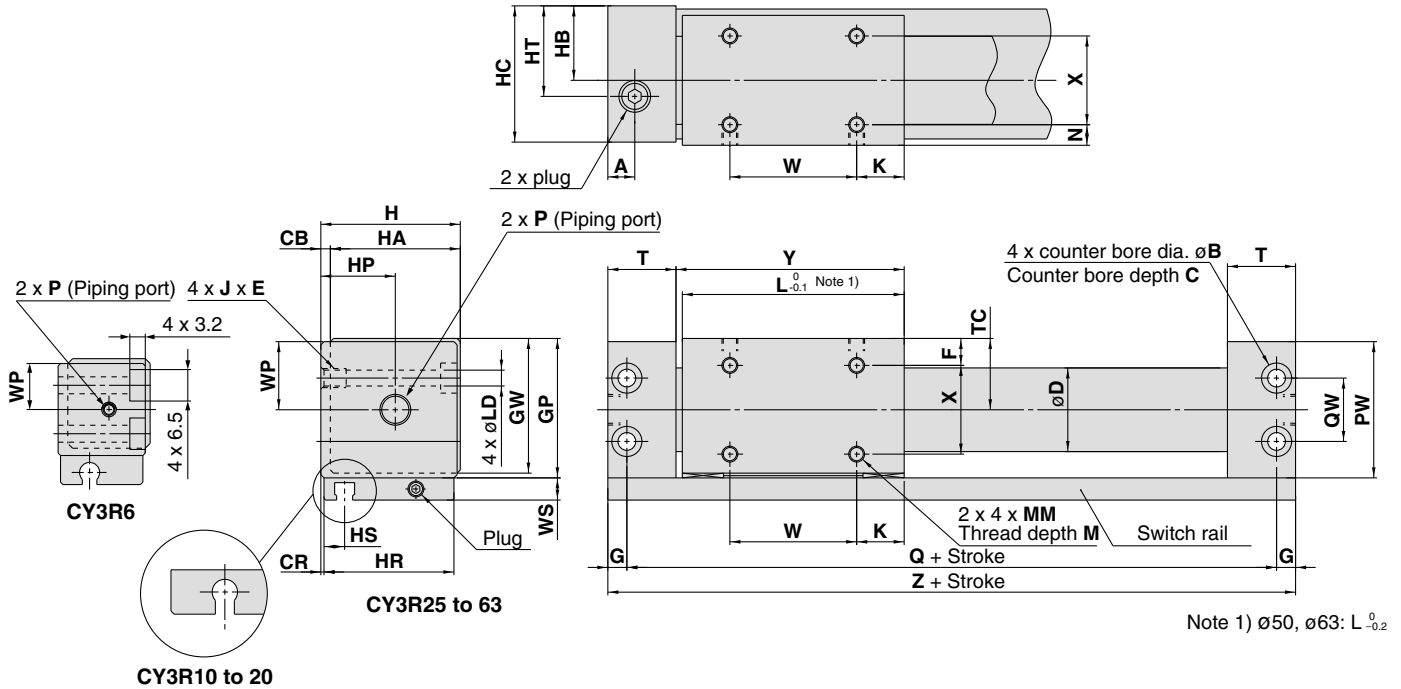

Note 1) $\varnothing 50, \varnothing 63$: $L_{-0.2}^0$

Model	A	B	C	CB	CR	D	F	G	GP	GW	H	HA	HB	HC	HP	HR	HS	HT	J x E	K
CY3R6	7*	—*	—*	2	0.5	7.6	5.5	3*	20	18.5	19	17	10.5	18	10.5*	17	6	10.5*	M4 x 0.7 x 6	7
CY3R10	9	6.5	3.2	2	0.5	12	6.5	4	27	25.5	26	24	14	25	14	24	5	14	M4 x 0.7 x 6	9
CY3R15	10.5	8	4.2	2	0.5	16.6*	8	5	33	31.5	32	30	17	31	17	30	8.5	17	M5 x 0.8 x 7	14
CY3R20	9	9.5	5.2	3	1	21.6*	9	6	39	37.5	39	36	21	38	24	36	7.5	24	M6 x 1 x 8	11
CY3R25	8.5	9.5	5.2	3	1	26.4*	8.5	6	44	42.5	44	41	23.5	43	23.5	41	6.5	23.5	M6 x 1 x 8	15
CY3R32	10.5	11	6.5	3	1.5	33.6*	10.5	7	55	53.5	55	52	29	54	29	51	7	29	M8 x 1.25 x 10	13
CY3R40	10	11	6.5	5	2	41.6*	13	7	65	63.5	67	62	36	66	36	62	8	36	M8 x 1.25 x 10	15
CY3R50	14	14	8.2	5	2	52.4*	17	8.5	83	81.5	85	80	45	84	45	80	9	45	M10 x 1.5 x 15	25
CY3R63	15	14	8.2	5	3	65.4*	18	8.5	95	93.5	97	92	51	96	51	90	9.5	51	M10 x 1.5 x 15	24

Model	L	LD	M	MM	N	PW	Q	QW	T	TC	W	WP	WS	X	Y	Z
CY3R6	34	3.5	3.5	M3 x 0.5	3.5	19	60*	10	14.5*	10.5	20	9.5	6	10	35.5	66*
CY3R10	38	3.5	4	M3 x 0.5	4.5	26	68	14	17.5	14	20	13	8	15	39.5	76
CY3R15	53	4.3	5	M4 x 0.7	6	32	84	18	19	17	25	16	7	18	54.5	94
CY3R20	62	5.4	5	M4 x 0.7	7	38	95	17	20.5	20	40	19	7	22	64	107
CY3R25	70	5.4	6	M5 x 0.8	6.5	43	105	20	21.5	22.5	40	21.5	7	28	72	117
CY3R32	76	7	7	M6 x 1	8.5	54	116	26	24	28	50	27	7	35	79	130
CY3R40	90	7	8	M6 x 1	11	64	134	34	26	33	60	32	7	40	93	148
CY3R50	110	8.6	10	M8 x 1.25	15	82	159	48	30	42	60	41	10	50	113	176
CY3R63	118	8.6	10	M8 x 1.25	16	94	171	60	32	48	70	47	10	60	121	188

Model	P (Piping port)		
	Nil	TN*	TF*
CY3R6	M3 x 0.5*	—	—
CY3R10	M5 x 0.8	—	—
CY3R15	M5 x 0.8	—	—
CY3R20	Rc 1/8	NPT 1/8	G 1/8
CY3R25	Rc 1/8	NPT 1/8	G 1/8
CY3R32	Rc 1/8	NPT 1/8	G 1/8
CY3R40	Rc 1/4	NPT 1/4	G 1/4
CY3R50	Rc 1/4	NPT 1/4	G 1/4
CY3R63	Rc 1/4	NPT 1/4	G 1/4

Note 2) The astrisk denotes the dimensions which are different from the CY1R series.

Dimensions

Centralized piping type: $\varnothing 10$ to $\varnothing 63$

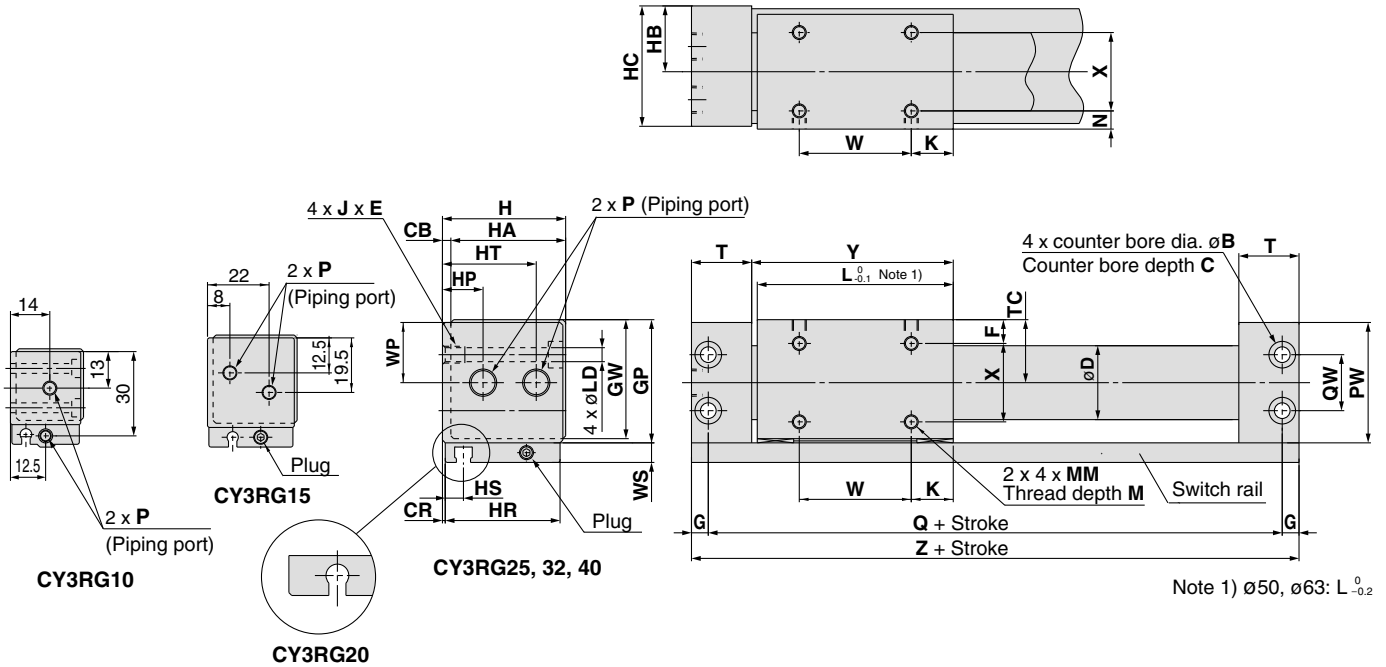

Model	B	C	CB	CR	D	F	G	GP	GW	H	HA	HB	HC	HP	HR	HS	HT	J x E	K	L
CY3RG10	6.5	3.2	2	0.5	12	6.5	4	27	25.5	26	24	14	25	—	24	5	—	M4 x 0.7 x 6	9	38
CY3RG15	8	4.2	2	0.5	16.6*	8	5	33	31.5	32	30	17	31	—	30	8.5	—	M5 x 0.8 x 7	14	53
CY3RG20	9.5	5.2	3	1	21.6*	9	6	39	37.5	39	36	21	38	11	36	7.5	28	M6 x 1 x 8	11	62
CY3RG25	9.5	5.2	3	1	26.4*	8.5	6	44	42.5	44	41	23.5	43	14.5	41	6.5	33.5	M6 x 1 x 8	15	70
CY3RG32	11	6.5	3	1.5	33.6*	10.5	7	55	53.5	55	52	29	54	20	51	7	41	M8 x 1.25 x 10	13	76
CY3RG40	11	6.5	5	2	41.6*	13	7	65	63.5	67	62	36	66	25	62	8	50	M8 x 1.25 x 10	15	90
CY3RG50	14	8.2	5	2	52.4*	17	8.5	83	81.5	85	80	45	84	32	80	9	56	M10 x 1.5 x 15	25	110
CY3RG63	14	8.2	5	3	65.4*	18	8.5	95	93.5	97	92	51	96	35	90	9.5	63.5	M10 x 1.5 x 15	24	118

Model	LD	M	MM	N	PW	Q	QW	T	TC	W	WP	WS	X	Y	Z
CY3RG10	3.5	4	M3 x 0.5	4.5	26	68	14	17.5	14	20	13	8	15	39.5	76
CY3RG15	4.3	5	M4 x 0.7	6	32	84	18	19	17	25	16	7	18	54.5	94
CY3RG20	5.4	5	M4 x 0.7	7	38	95	17	20.5	20	40	19	7	22	64	107
CY3RG25	5.4	6	M5 x 0.8	6.5	43	105	20	21.5	22.5	40	21.5	7	28	72	117
CY3RG32	7	7	M6 x 1	8.5	54	116	26	24	28	50	27	7	35	79	130
CY3RG40	7	8	M6 x 1	11	64	134	34	26	33	60	32	7	40	93	148
CY3RG50	8.6	10	M8 x 1.25	15	82	159	48	30	42	60	41	10	50	113	176
CY3RG63	8.6	10	M8 x 1.25	16	94	171	60	32	48	70	47	10	60	121	188

Model	P (Piping port)		
	Nil	TN*	TF*
CY3RG10	M5 x 0.8	—	—
CY3RG15	M5 x 0.8	—	—
CY3RG20	Rc 1/8	NPT 1/8	G 1/8
CY3RG25	Rc 1/8	NPT 1/8	G 1/8
CY3RG32	Rc 1/8	NPT 1/8	G 1/8
CY3RG40	Rc 1/4	NPT 1/4	G 1/4
CY3RG50	Rc 1/4	NPT 1/4	G 1/4
CY3RG63	Rc 1/4	NPT 1/4	G 1/4

Note 2) The astrisk denotes the dimensions which are different from the CY1RG series.

Series CY3B/CY3R

Auto Switch Proper Mounting Position for Stroke End Detection

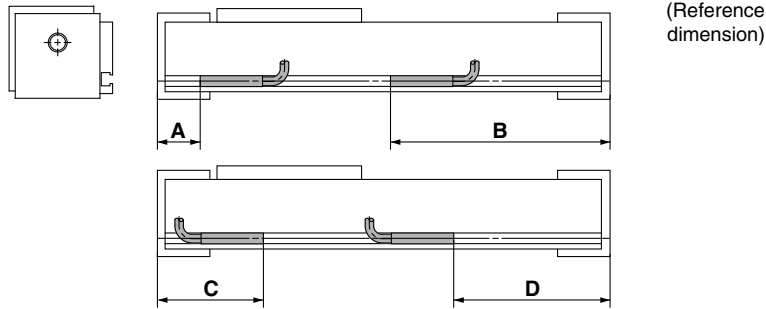

Auto Switch Proper Mounting Position

ø6 to ø20

(mm)

Auto switch model Bore size (mm)	A		B		C		D	
	D-A9□	D-M9□ D-M9□W	D-A9□	D-M9□ D-M9□W	D-A9□	D-M9□ D-M9□W	D-A9□	D-M9□ D-M9□W
6	26	30	46	42	46	42	26	30
10	28	32	48	44	48	44	—	32
15	17.5	21.5	76.5	72.5	—	—	56.5	60.5
20	19.5	23.5	87.5	83.5	39.5	35.5	67.5	71.5

Note 1) Auto switches cannot be installed in Area C in the case of ø15.

Note 2) D-A9□ type cannot be mounted on the section D of ø10.

Note 3) The above values are a guideline of the auto switch mounting position when detected at the stroke end. Adjust the auto switch after confirming the operating conditions in the actual setting.

Note 4) D-Z7□ and D-Y□ types cannot be mounted.

ø25 to ø63

(mm)

Auto switch model Bore size (mm)	A			B			C			D		
	D-A9□	D-M9□ D-M9□W	D-Z7□ D-Z80 D-Y59□ D-Y7P D-Y7□W	D-A9□	D-M9□ D-M9□W	D-Z7□ D-Z80 D-Y59□ D-Y7P D-Y7□W	D-A9□	D-M9□ D-M9□W	D-Z7□ D-Z80 D-Y59□ D-Y7P D-Y7□W	D-A9□	D-M9□ D-M9□W	D-Z7□ D-Z80 D-Y59□ D-Y7P D-Y7□W
25	19	23	18	98	94	99	42	38	43	75	79	74
32	22.5	26.5	21.5	107.5	103.5	108.5	45.5	41.5	46.5	84.5	88.5	83.5
40	24.5	28.5	23.5	123.5	119.5	124.5	47.5	43.5	48.5	100.5	104.5	99.5
50	28.5	32.5	27.5	147.5	143.5	148.5	51.5	47.5	52.5	124.5	128.5	123.5
63	30.5	34.5	29.5	157.5	153.5	158.5	53.5	49.5	54.5	134.5	138.5	133.5

Note 1) 50 mm is the minimum stroke available with 2 auto switches mounted.

Note 2) Figures in the table above are used as a reference when mounting the auto switches for stroke end detection. In the case of actually setting the auto switches, adjust them after confirming their operation.

Note 3) Auto switch brackets are required when ordering D-A9□/M9□/M9□W types and cylinders separately. (Refer to the auto switch mounting bracket: part no. on page 1185.)

Magnetically Coupled Rodless Cylinder *Series CY3B/CY3R*

Auto Switch Operation Range

Auto switch model	Bore size (mm)								
	6	10	15	20	25	32	40	50	63
D-A9□	8	11	8	6	6	7	9	8	8
D-M9□ D-M9□W	4.5	6.5	6.5	4	5	5.5	5.5	6.5	7
D-Z7□/Z80	—	—	—	—	9	9	11	9	10
D-Y59□/Y7P/Y7□W	—	—	—	—	5	5	6	6	6

- * The auto switches cannot be mounted in some cases.
- * Since the operating range is provided as a guideline including hysteresis, it cannot be guaranteed (assuming approximately ±30% dispersion). It may vary substantially depending on an ambient environment.

Auto Switch Mounting Bracket/Part No.

Auto switch model	Bore size (mm)
	ø25 to ø63
D-A9□ D-M9□ D-M9□W	BMG2-012

D-A9□/M9□/M9□W

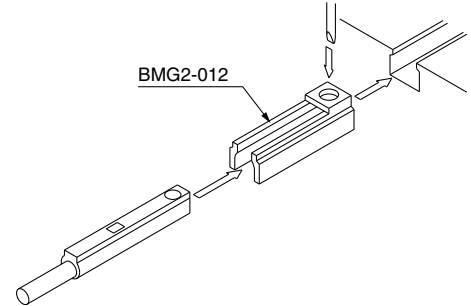

Other than the applicable auto switches listed in “How to Order”, the following auto switches can be mounted. For detailed specifications, refer to pages 1263 to 1371.

Type	Model	Electrical entry	Features	Applicable bore size
Reed auto switch	D-Z73, Z76	Grommet (In-line)	—	ø25 to ø63
	D-Z80		Without indicator light	
Solid state auto switch	D-Y59A, Y59B, Y7P	Grommet (In-line)	—	
	D-Y7NW, Y7PW, Y7BW		Diagnostic indication (2-color display)	

- * With pre-wired connector is also available in solid state auto switches. For specifications, refer to pages 1328 and 1329.
- * Normally closed (NC = b contact), solid state switch (D-F9G/F9H/Y7G/Y7H type) are also available. For details, refer to pages 1290 and 1292.
- * Applicable bore sizes are ø25 to ø63.

CY3B
CY3R

CY1S

CY1L

CY1H

CY1F

CYP

D-□

-X□

Individual
-X□

Technical
data



Series CY3B/CY3R Specific Product Precautions 1

Be sure to read before handling.

Refer to front matters 54 and 55 for Safety Instructions and pages 3 to 11 for Actuator and Auto Switch Precautions.

Handling

Warning

- 1. Pay attention to the space between the head cover and the body.**
Take sufficient care to avoid getting your hands or fingers caught when the cylinder is operated.
- 2. Do not apply a load to a cylinder which is greater than the allowable value stated in the Model Selection.**
Applying an improper load may cause malfunctions.
- 3. When the cylinder is used in a place where water or cutting oil may splash it or the lubrication on its sliding parts could be deteriorate, please consult with SMC.**
- 4. When applying grease to the cylinder, use the grease that has already been applied to the product. Contact SMC for available grease packs.**

Mounting

Caution

- 1. Take care to avoid nicks or other damage on the outside surface of the cylinder tube.**
This can lead to damage of the wear ring and lubretainer, which in turn can cause malfunction.
- 2. Take care regarding rotation of the external slider.**
Rotation should be controlled by connecting it to another shaft (linear guide, etc.).
- 3. Do not operate with the magnetic coupling out of position.**
In case the magnetic coupling is out of position, push the external slider back into the correct position by hand at the end of the stroke (or correct the piston slider with air pressure).
- 4. The cylinder is mounted with bolts through the mounting holes in the end covers. Be sure they are tightened securely. (CY3R)**
- 5. If gaps occur between the mounting surface and the end covers when mounting with bolts, perform shim adjustment using spacers, etc. so that there is no unreasonable stress. (CY3R)**
- 6. Be sure that both end covers are secured to the mounting surface before operating the cylinder.**
Avoid operation with the external slider secured to the surface.

Mounting

Caution

- 7. Do not apply a lateral load to the external slider.**

When a load is mounted directly to the cylinder, variations in the alignment of each shaft center cannot be assimilated, which results in the generation of a lateral load that can cause malfunction. (Figure 1) The cylinder should be operated using a connection method which allows for assimilation of shaft alignment variations and deflection due to the cylinder's own mass. A drawing of a recommended mounting is shown in Figure 2.

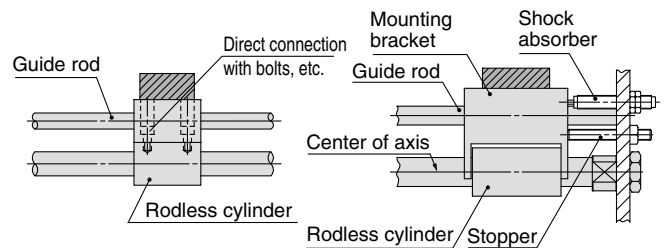

Variations in the load and cylinder shaft alignment cannot be assimilated, resulting in malfunction.

Shaft alignment variations are assimilated by providing clearance for the mounting bracket and cylinder. Moreover, the mounting bracket is extended above the cylinder shaft center, so that the cylinder is not subjected to moment.

Figure 1. Incorrect mounting

Figure 2. Recommended mounting

Note) The drawing shows the CY3B series.

- 8. Use caution regarding the allowable load mass when operating in a vertical direction.**
The allowable load mass when operating in a vertical direction (reference values on page 1172) is determined by the model selection method, however, if a load greater than the allowable value is applied, the magnetic coupling may break and there is a possibility of dropping the load. When using this type of application, contact SMC regarding the operating conditions (pressure, load, speed, stroke, frequency, etc.).
- 9. Careful alignment is necessary when connecting to a load having an external guide mechanism.**
As the stroke becomes longer, variations in the center axis become larger. Consider using a connection method (floating mechanism) that is able to absorb these variations. Furthermore, use the special floating brackets (XC57) which have been provided for the CY3B and CY3R series (page 1483).



Series CY3B/CY3R

Specific Product Precautions 2

Be sure to read before handling.

Refer to front matters 54 and 55 for Safety Instructions and pages 3 to 11 for Actuator and Auto Switch Precautions.

Disassembly & Maintenance

Warning

1. Use caution as the attractive power of the magnets is very strong.

When removing the external slider and piston slider from the cylinder tube for maintenance, etc., handle with caution, since the magnets installed in each slider have very strong attractive power.

Caution

1. When reattaching the head covers after disassembly, confirm that they are tightened securely. (CY3B)

When disassembling, hold the wrench flat section of one head cover with a vise, and remove the other cover using a spanner or adjustable angle wrench on its wrench flat section. When retightening, first coat with Locktight (No. 542 red), and retighten 3 to 5° past the original position prior to removal.

2. Special tools are necessary for disassembly. (CY3R)

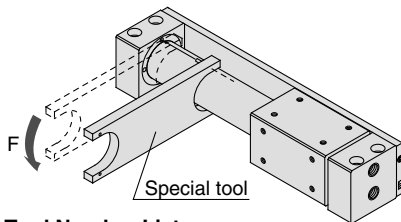

Special Tool Number List

Part no.	Applicable bore size (mm)
CYRZ-V	6, 10, 15, 20
CYRZ-W	25, 32, 40
CYRZ-X	50
CYRZ-Y	63

3. Use caution when taking off the external slider, as the piston slider will be directly attracted to it.

When removing the external slider or piston slider from the cylinder tube, first force the sliders out of their magnetically coupled positions and then remove them individually while there is no longer any holding force. If they are removed when still magnetically coupled, they will be directly attracted to one another and will not come apart.

4. Do not disassemble the magnetic components (piston slider, external slider).

This can cause a loss of holding force and malfunction.

5. When disassembling to replace the seals and wear ring, refer to the separate disassembly instructions.

Disassembly & Maintenance

Caution

6. Note the direction of the external slider and piston slider.

Since the external slider and piston slider are directional for $\phi 6$ and $\phi 10$, refer to the figures below when performing disassembly or maintenance. Put the external slider and piston slider together, and insert the piston slider into the cylinder tube so that they will have the correct positional relationship as shown in Figure 3. If they align as shown in Figure 4, insert the piston slider after turning it around 180°. If the direction is not correct, it will be impossible to obtain the specified holding force.

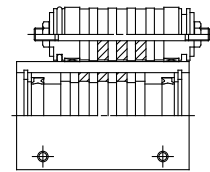
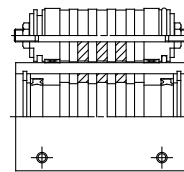

Figure 3. Correct position

Figure 4. Incorrect position

For $\phi 6$ and $\phi 10$

CY3B
CY3R

CY1S

CY1L

CY1H

CY1F

CYP

D-□

-X□

Individual
-X□

Technical
data

Slider Type/Slide Bearing

Series *CY1S*

ø6, ø10, ø15, ø20, ø25, ø32, ø40



CY3B
CY3R

CY1S

CY1L

CY1H

CY1F

CYP

D-□

-X□

Individual
-X□

Technical
data

Series CY1S

Model Selection 1

E: Kinetic energy of load (J)

$$E = \frac{W}{2} \cdot \left(\frac{V}{1000}\right)^2$$

Es: Allowable kinetic energy for intermediate stop using an air pressure circuit (J)

Ps: Operating pressure limit for intermediate stop using an external stopper, etc. (MPa)

Pv: Maximum operating pressure for vertical operation (MPa)

W_A: Allowable load mass based on these operating conditions (kg)

W_v: Allowable load mass for vertical operation (kg)

F_A: Allowable drive resisting force at pusher (kg)

σ: Stroke coefficient

$$\sigma = \frac{\text{Load mass within stroke}}{\text{Maximum load mass}}$$

Operating Conditions

- W: Load mass (kg)
- P: Operating pressure (MPa)
- L_o: Distance from slide block mounting surface to workpiece center of gravity (cm)
- Mode of operation (Horizontal, Inclined, Vertical)
- F: Drive resisting force (kg)
- V: Speed (mm/s)
- Stroke (mm)

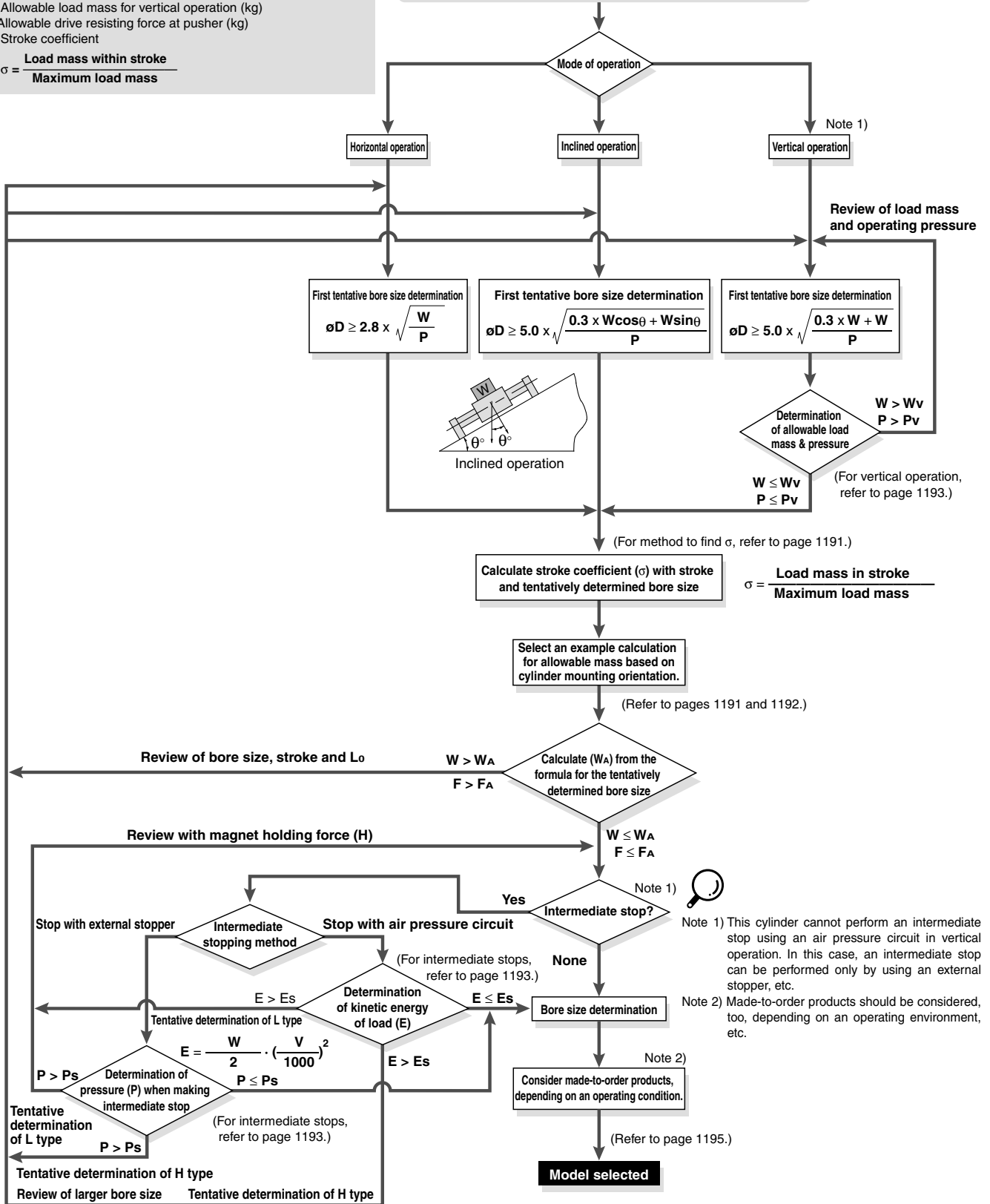

Series CY1S

Model Selection 2

Caution on Design (1)

How to Find σ when Selecting the Allowable Load Mass

Since the maximum load mass with respect to the cylinder stroke changes as shown in the table below, σ should be considered as a coefficient determined in accordance with each stroke.

Example) CY1S25□-650

- (1) Maximum load mass = 20 kg
- (2) Load mass for 650 st = 13.6 kg
- (3) $\sigma = \frac{13.6}{20} = 0.68$ is the result.

Calculation Formula for σ ($\sigma \leq 1$)

ST: Stroke (mm)

Model	CY1S6	CY1S10	CY1S15
$\sigma =$	1	$10^{(0.86 - 1.3 \times 10^{-3} \times \text{ST})}$ 3	$10^{(1.5 - 1.3 \times 10^{-3} \times \text{ST})}$ 7

Model	CY1S20	CY1S25	CY1S32
$\sigma =$	$\frac{10^{(1.71 - 1.3 \times 10^{-3} \times \text{ST})}}{12}$	$\frac{10^{(1.98 - 1.3 \times 10^{-3} \times \text{ST})}}{20}$	$\frac{10^{(2.26 - 1.3 \times 10^{-3} \times \text{ST})}}{30}$

Model	CY1S40
$\sigma =$	$\frac{10^{(2.48 - 1.3 \times 10^{-3} \times \text{ST})}}{50}$

Note) Calculate with $\sigma = 1$ for all applications up to $\phi 10 - 300$ mmST, $\phi 15 - 500$ mmST, $\phi 20 - 500$ mmST, $\phi 25 - 500$ mmST, $\phi 32 - 600$ mmST and $\phi 40 - 600$ mmST.

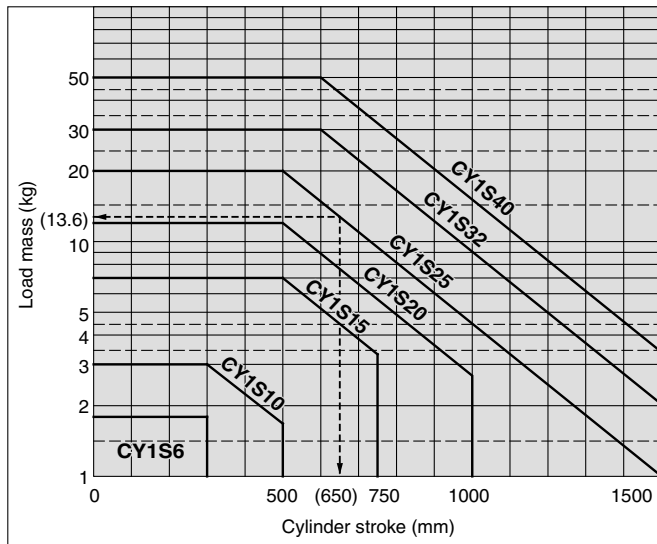

Example of Allowable Load Mass Calculation Based on Cylinder Mounting Orientation

1. Horizontal Operation (Floor mounting)

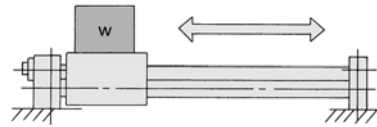

Maximum Load Mass (Center of slide block) (kg)

Bore size (mm)	6	10	15	20	25	32	40
Max. load mass (kg)	1.8	3	7	12	20	30	50
Stroke (Max)	Up to 300 st	Up to 300 st	Up to 500 st	Up to 500 st	Up to 500 st	Up to 600 st	Up to 600 st

The above maximum load mass values will change with the stroke length for each cylinder size, due to limitation from warping of the guide shafts. (Take note of the coefficient σ .) Moreover, depending on the operating direction, the allowable load mass may be different from the maximum load mass.

2. Horizontal Operation (Wall mounting)

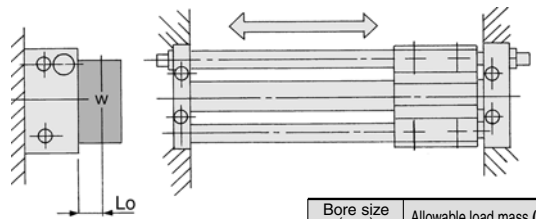

Lo: Distance from mounting surface to load center of gravity (cm)

Bore size (mm)	Allowable load mass (W _a) (kg)
6	$\frac{\sigma \cdot 5.44}{7 + 2Lo}$
10	$\frac{\sigma \cdot 12.0}{8.4 + 2Lo}$
15	$\frac{\sigma \cdot 36.4}{10.6 + 2Lo}$
20	$\frac{\sigma \cdot 74.4}{12 + 2Lo}$
25	$\frac{\sigma \cdot 140}{13.8 + 2Lo}$
32	$\frac{\sigma \cdot 258}{17 + 2Lo}$
40	$\frac{\sigma \cdot 520}{20.6 + 2Lo}$

3. Vertical Operation

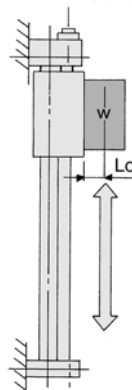

Bore size (mm)	Allowable load mass (W _v) (kg)
6	$\frac{\sigma \cdot 1.33}{1.9 + Lo}$
10	$\frac{\sigma \cdot 4.16}{2.2 + Lo}$
15	$\frac{\sigma \cdot 13.23}{2.7 + Lo}$
20	$\frac{\sigma \cdot 26.8}{2.9 + Lo}$
25	$\frac{\sigma \cdot 44.0}{3.4 + Lo}$
32	$\frac{\sigma \cdot 88.2}{4.2 + Lo}$
40	$\frac{\sigma \cdot 167.8}{5.1 + Lo}$

Lo: Distance from mounting surface to load center of gravity (cm)

Note) Operating pressure should be equal to or less than the maximum operating pressure in the article, "Vertical Operation" listed on page 1193.

CY3B
CY3R

CY1S

CY1L

CY1H

CY1F

CYP

D-□

-X□

Individual

-X□

Technical data

Caution on Design (2)

Example of Allowable Load Mass Calculation Based on Cylinder Mounting Orientation

4. Inclined Operation (In operating direction)

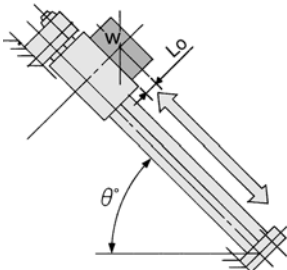

Angle	to 45°	to 60°	to 75°	to 90°
k	1	0.9	0.8	0.7

Angle coefficient (k): $k = [\text{to } 45^\circ (= \theta)] = 1$,
 $[\text{to } 60^\circ] = 0.9$, $[\text{to } 75^\circ] = 0.8$,
 $[\text{to } 90^\circ] = 0.7$

Lo: Distance from mounting surface to load center of gravity (cm)

Bore size (mm)	Allowable load mass (WA) (kg)
6	$\sigma \cdot 5.1 \text{ K}$
	$3\cos \theta + 2 (1.9 + \text{Lo}) \sin \theta$
10	$\sigma \cdot 10.5 \text{ K}$
	$3.5\cos \theta + 2 (2.2 + \text{Lo}) \sin \theta$
15	$\sigma \cdot 35 \text{ K}$
	$5\cos \theta + 2 (2.7 + \text{Lo}) \sin \theta$
20	$\sigma \cdot 72 \text{ K}$
	$6\cos \theta + 2 (2.9 + \text{Lo}) \sin \theta$
25	$\sigma \cdot 120 \text{ K}$
	$6\cos \theta + 2 (3.4 + \text{Lo}) \sin \theta$
32	$\sigma \cdot 210 \text{ K}$
	$7\cos \theta + 2 (4.2 + \text{Lo}) \sin \theta$
40	$\sigma \cdot 400 \text{ K}$
	$8\cos \theta + 2 (5.1 + \text{Lo}) \sin \theta$

5. Inclined Operation (At a right angle to operating direction)

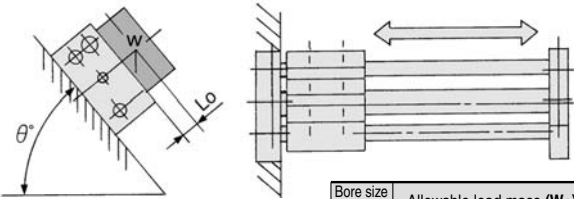

Lo: Distance from mounting surface to load center of gravity (cm)

Bore size (mm)	Allowable load mass (WA) (kg)
6	$\sigma \cdot 5.44$
	$3.2 + 2 (1.9 + \text{Lo}) \sin \theta$
10	$\sigma \cdot 12.0$
	$4 + 2 (2.2 + \text{Lo}) \sin \theta$
15	$\sigma \cdot 36.4$
	$5.2 + 2 (2.7 + \text{Lo}) \sin \theta$
20	$\sigma \cdot 74.4$
	$6.2 + 2 (2.9 + \text{Lo}) \sin \theta$
25	$\sigma \cdot 140$
	$7 + 2 (3.4 + \text{Lo}) \sin \theta$
32	$\sigma \cdot 258$
	$8.6 + 2 (4.2 + \text{Lo}) \sin \theta$
40	$\sigma \cdot 520$
	$10.4 + 2 (5.1 + \text{Lo}) \sin \theta$

6. Load Center Offset in Operating Direction (Lo)

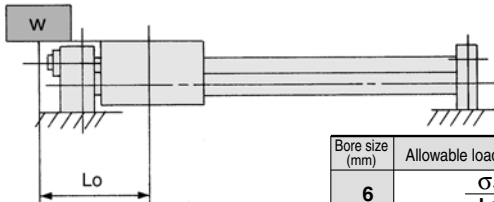

Lo: Distance from center of slide block to load's center of gravity (cm)

Bore size (mm)	Allowable load mass (WA) (kg)
6	$\sigma \cdot 2.55$
	$\text{Lo} + 3$
10	$\sigma \cdot 5.25$
	$\text{Lo} + 3.5$
15	$\sigma \cdot 17.5$
	$\text{Lo} + 5.0$
20	$\sigma \cdot 36$
	$\text{Lo} + 6.0$
25	$\sigma \cdot 60$
	$\text{Lo} + 6.0$
32	$\sigma \cdot 105$
	$\text{Lo} + 7.0$
40	$\sigma \cdot 200$
	$\text{Lo} + 8.0$

7. Horizontal Operation (Pushing load, Pusher)

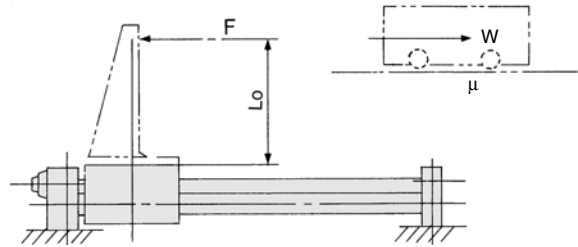

F: Drive (from slide block to position Lo) resistance force $W \times \mu$ (kg)
 Lo: Distance from mounting surface to load center of gravity (cm)
 μ : Friction coefficient

Bore size (mm)	6	10	15	20
Allowable drive resisting force (FA) (kg)	$\frac{\sigma \cdot 2.55}{1.9 + \text{Lo}}$	$\frac{\sigma \cdot 5.25}{2.2 + \text{Lo}}$	$\frac{\sigma \cdot 17.5}{2.7 + \text{Lo}}$	$\frac{\sigma \cdot 36}{2.9 + \text{Lo}}$

Bore size (mm)	25	32	40
Allowable drive resisting force (FA) (kg)	$\frac{\sigma \cdot 60}{3.4 + \text{Lo}}$	$\frac{\sigma \cdot 105}{4.2 + \text{Lo}}$	$\frac{\sigma \cdot 200}{5.1 + \text{Lo}}$

8. Horizontal Operation (Load, Lateral offset Lo)

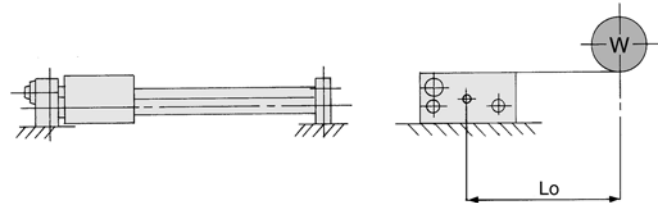

Lo: Distance from mounting surface to load center of gravity (cm)

Bore size (mm)	6	10	15	20
Allowable load mass (WA) (kg)	$\frac{\sigma \cdot 3.80}{3.2 + \text{Lo}}$	$\frac{\sigma \cdot 8.40}{4 + \text{Lo}}$	$\frac{\sigma \cdot 25.48}{5.2 + \text{Lo}}$	$\frac{\sigma \cdot 52.1}{6.2 + \text{Lo}}$

Bore size (mm)	25	32	40
Allowable load mass (WA) (kg)	$\frac{\sigma \cdot 98}{7.0 + \text{Lo}}$	$\frac{\sigma \cdot 180}{8.6 + \text{Lo}}$	$\frac{\sigma \cdot 364}{10.4 + \text{Lo}}$

Caution on Design (3)

Vertical Operation

When operating a load vertically, it should be operated within the allowable load mass and maximum operating pressures shown in the table below. Use caution, as operating above the prescribed values may lead to dropping of the load.

When the cylinder is mounted vertically or sidelong, sliders may move downwards due to the self-weight or workpiece mass. If an accurate stopping position is required at the stroke end or the middle-stroke, use an external stopper to secure accurate positioning.

Bore size (mm)	Model	Allowable load mass (Wv) (kg)	Maximum operating pressure (Pv) (MPa)
6	CY1S 6H	1.0	0.55
10	CY1S10H	2.7	0.55
15	CY1S15H	7.0	0.65
	CY1S15L	4.1	0.40
20	CY1S20H	11.0	0.65
	CY1S20L	7.0	0.40
25	CY1S25H	18.5	0.65
	CY1S25L	11.2	0.40
32	CY1S32H	30.0	0.65
	CY1S32L	18.2	0.40
40	CY1S40H	47.0	0.65
	CY1S40L	29.0	0.40

Note 1) Use caution, since the magnetic coupling may be dislocated if it is used over the maximum operating pressure.

Note 2) Allowable load mass above indicates the maximum load mass when loaded. The actual loadable mass must be determined referring to the flow chart in the Model Selection 1.

Intermediate Stop

1) Intermediate stopping of load with an external stopper, etc.

When stopping a load in mid-stroke using an external stopper (adjusting bolt, etc.), operate within the operating pressure limits shown in the table below. Use caution, as operation at a pressure exceeding these limits can result in breaking of the magnetic coupling.

Bore size (mm)	Model	Operating pressure limit for intermediate stop (Ps) (MPa)
6	CY1S 6H	0.55
10	CY1S10H	0.55
15	CY1S15H	0.65
	CY1S15L	0.40
20	CY1S20H	0.65
	CY1S20L	0.40
25	CY1S25H	0.65
	CY1S25L	0.40
32	CY1S32H	0.65
	CY1S32L	0.40
40	CY1S40H	0.65
	CY1S40L	0.40

2) Intermediate stopping of load with an air pressure circuit

When stopping a load using an air pressure circuit, operate at or below the kinetic energy shown in the table below. Use caution, as operation when exceeding the allowable value can result in breaking of the magnetic coupling.

(Reference values)

Bore size (mm)	Model	Allowable kinetic energy for intermediate stop (Es) (J)
6	CY1S 6H	0.007
10	CY1S10H	0.03
15	CY1S15H	0.13
	CY1S15L	0.076
20	CY1S20H	0.24
	CY1S20L	0.16
25	CY1S25H	0.45
	CY1S25L	0.27
32	CY1S32H	0.88
	CY1S32L	0.53
40	CY1S40H	1.53
	CY1S40L	0.95

CY3B
CY3R

CY1S

CY1L

CY1H

CY1F

CYP

D-□

-X□

Individual
-X□

Technical
data

Magnetically Coupled Rodless Cylinder Slider Type: Slide Bearing

Series *CY1S*

ø6, ø10, ø15, ø20, ø25, ø32, ø40

How to Order

CY1S 25 H - 300 -

With auto switch **CDY1S 25 H - 300 - J79W -**

With switch rail

Slider type (Slide bearing)

Bore size

6	6 mm	25	25 mm
10	10 mm	32	32 mm
15	15 mm	40	40 mm
20	20 mm		

Port thread type

Symbol	Type	Bore size
Nil	M thread	ø6, ø10, ø15
	Rc	ø20, ø25, ø32, ø40
TN	NPT	ø20, ø25, ø32, ø40
TF	G	ø20, ø25, ø32, ø40

Magnetic holding force
Refer to page 1195 for specifications.

Standard stroke
Refer to "Standard Stroke" on page 1195.

Made to Order
Refer to page 1195 for details.

Number of auto switches

Nil	2 pcs.
S	1 pc.
n	"n" pcs.

Auto switch

Nil	Without auto switch (Built-in magnet)
-----	---------------------------------------

* For the applicable auto switch model, refer to the table below.

Adjustment type

Nil	With adjusting bolt
B	With shock absorbers (2 pcs.)
BS	With shock absorber (With plate A) * Installed on Side A at time of shipment.

Applicable Auto Switch/Refer to pages 1263 to 1371 for further information on auto switches.

Type	Special function	Electrical entry	Indicator/light	Wiring (Output)	Load voltage		Auto switch model		Lead wire length (m)*				Pre-wired connector	Applicable load	
					DC	AC	Electrical entry direction		0.5 (Nil)	3 (L)	5 (Z)	None (N)		IC circuit	Relay, PLC
							Perpendicular	In-line							
Solid state switch	—	Grommet	Yes	3-wire (NPN)	5 V, 12 V	—	F7NV	F79	●	●	○	—	○	IC circuit	Relay, PLC
				3-wire (PNP)			F7PV	F7P	●	●	○	—	○		
		Connector		2-wire	12 V	—	—	●	●	○	—	○	—		
	Grommet			3-wire (NPN)	24 V	5 V, 12 V	F7NWV	F79W	●	●	○	—	○	IC circuit	
		3-wire (PNP)		—			F7PW	●	●	○	—	○	IC circuit		
		2-wire		12 V	F7BWV	J79W	●	●	○	—	○	—			
		4-wire (NPN)	5 V, 12 V	—	F79F	●	●	○	—	○	IC circuit				
Reed switch	—	Grommet	Yes	3-wire (NPN equivalent)	—	5 V	—	—	A76H	●	●	—	—	IC circuit	Relay, PLC
				Connector	24 V	12 V	100 V	A72	A72H	●	●	—	—	—	
								A73	A73H	●	●	●	—	—	
		No/Yes/No			5 V, 12 V	100 V or less	A80	A80H	●	●	—	—	—	IC circuit	
							12 V	—	A73C	—	●	●	●	●	
		5 V, 12 V		—	—	A80C	—	●	●	●	●	—	IC circuit		

* Lead wire length symbols: 0.5 m..... Nil (Example) J79W
 3 m..... L (Example) J79WL
 5 m..... Z (Example) J79WZ
 None..... N (Example) J79CN

* Solid state auto switches marked with "○" are produced upon receipt of order.

- Since there are other applicable auto switches than listed, refer to page 1199 for details.
- For details about auto switches with pre-wired connector, refer to pages 1328 and 1329.
- * Auto switches are shipped together, (but not assembled).

Magnetically Coupled Rodless Cylinder Slider Type: Slide Bearing **Series CY1S**

Specifications



Made to Order Specifications
(For details, refer to pages 1395 to 1565.)

Symbol	Specifications
—XB9	Low speed cylinder (15 to 50 mm/s)
—XB13	Low speed cylinder (7 to 50 mm/s)
—X116	Hydro specifications rodless cylinder
—X168	Helical insert thread specifications
—X210	Non-lubricated exterior specifications
—X322	Outside of cylinder tube with hard chrome plated
—X324	Non-lubricated exterior specifications (With dust seal)
—X431	Auto switch rails on both side faces (with 2 pcs.)

Amount of Adjustment for Adjusting Bolt and Shock Absorber

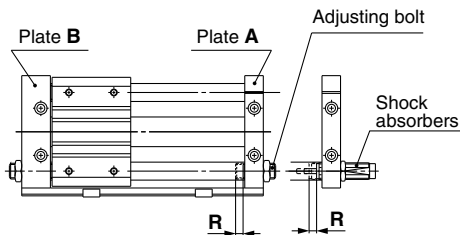

Bore size (mm)	R	Amount of adjustment by adjusting bolt (both ends: R x 2) (mm)
6	0 to 6	12
10	0 to 5.5	11
15	0 to 3.5	7
20	0 to 5.5	11
25	0 to 5	10
32	0 to 5.5	11
40	0 to 4.5	9

Bore size (mm)	Amount of adjustment by shock absorber: R (mm)	
	Plate A side	Plate B side
6	17	11
10	14	6
15	14	4
20	16	7
25	32	23
32	33	23
40	32	17

* Since the cylinder is in an intermediate stop condition when stroke adjustment is performed, use caution regarding the operating pressure and the kinetic energy of the load.

* The amount of adjustment for adjustment bolts is the total amount when adjusted on both plate ends. For the adjustment on a single plate end, the amount of adjustment is half of the figures in the table above.

* The Plate A: Piping port side

Bore size (mm)	6	10	15	20	25	32	40	
Fluid	Air							
Proof pressure	1.05 MPa							
Maximum operating pressure	0.7 MPa							
Minimum operating pressure	0.18 MPa							
Ambient and fluid temperature	-10 to 60°C							
Piston speed *	50 to 400 mm/s							
Cushion	Rubber bumper / Shock absorbers							
Lubrication	Non-lube							
Stroke length tolerance	0 to 250 st: $+1.0_0$, 251 to 1000 st: $+1.4_0$, 1001 st and up: $+1.8_0$							
Holding force	Type H	19.6	53.9	137	231	363	588	922
	Type L	—	—	81.4	154	221	358	569

* In the case of setting an auto switch (CDY1S) at the intermediate position, the maximum piston speed is subject to restrict for detection upon the response time of a load (Relays, Sequence controller, etc.)

Standard Stroke

Bore size (mm)	Standard stroke (mm)	Maximum manufacturable stroke (mm)
6	50, 100, 150, 200	300
10	50, 100, 150, 200, 250, 300	500
15	50, 100, 150, 200, 250, 300, 350 400, 450, 500	750
20	100, 150, 200, 250, 300, 350 400, 450, 500, 600, 700, 800	1000
25		1500
32		1500
40	100, 150, 200, 250, 300, 350 400, 450, 500, 600, 700, 800 900, 1000	1500

Note) Intermediate stroke is available by the 1 mm interval.

Mass

Number of magnets	Bore size (mm)	(kg)						
		6	10	15	20	25	32	40
Basic mass	CY1S□H	0.27	0.48	0.91	1.48	1.84	3.63	4.02
	CY1S□L	—	—	0.85	1.37	1.75	3.48	3.84
Additional mass per each 50 mm of stroke		0.044	0.074	0.104	0.138	0.172	0.267	0.406

Calculation

(Example) CY1S32H-500

• Basic mass 3.63 kg • Additional mass 0.267/50 st
• Cylinder stroke 500 st $3.63 + 0.267 \times 500 \div 50 = 6.3$ kg

Shock Absorber Specifications

Refer to the Series RB in Best Pneumatics No. 3 for the details on shock absorbers.

Applicable rodless cylinder	CY1S10 ⁶ ₁₅	CY1S20	CY1S25	CY1S ³² ₄₀	
Shock absorber model	RB0805	RB1006	RB1411	RB2015	
Maximum energy absorption: (J)	0.98	3.92	14.7	58.8	
Stroke absorption: (mm)	5	6	11	15	
Collision speed: (m/s)	0.05 to 5				
Max. operating frequency: (cycle/min) *	80	70	45	25	
Ambient temperature range	-10 to 80 °C				
Spring force: (N)	Extended	1.96	4.22	6.86	8.34
	Retracted	3.83	6.18	15.3	20.50

* It denotes the values at the maximum energy absorption per one cycle. Therefore, the operating frequency can be increased according to the energy absorption.

The shock absorber service life is different from that of the CY1S cylinder. Refer to the Specific Product Precautions for the replacement period.

Series CY1S

Construction

Slider type/Slide bearing

CY1S6 to 40

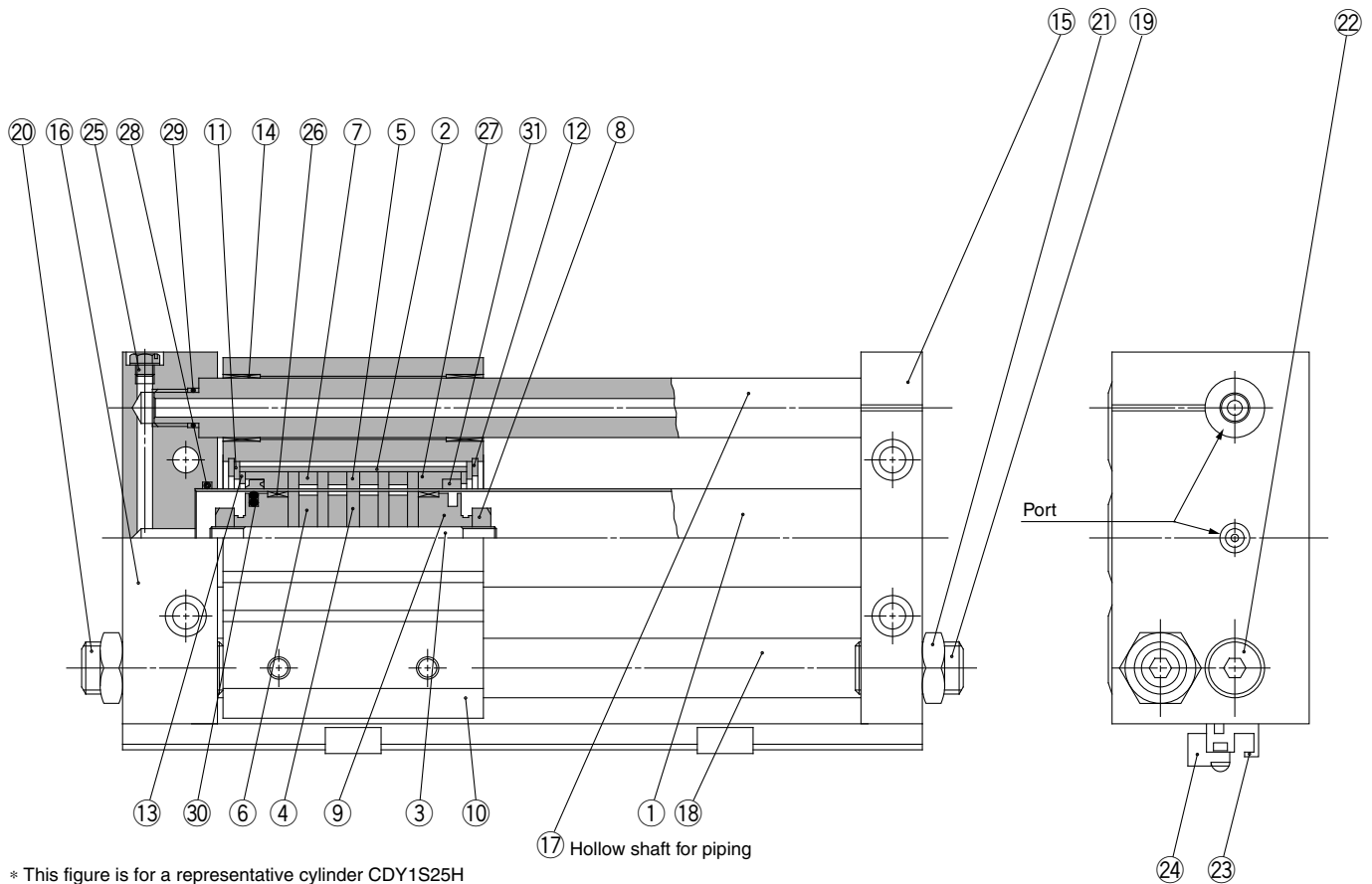

* This figure is for a representative cylinder CDY1S25H

Component Parts

No.	Description	Material	Note
1	Cylinder tube	Stainless steel	
2	External slider tube	Aluminum alloy	
3	Shaft	Stainless steel	
4	Piston side yoke	Rolled steel	Zinc chromated
5	External slider side yoke	Rolled steel	Zinc chromated
6	Magnet A	—	
7	Magnet B	—	
8	Piston nut	Carbon steel	Zinc chromated
9	Piston	Aluminum alloy ^{Note 1)}	Chromated
10	Slide block	Aluminum alloy	Anodized
11	Slider spacer	Rolled steel	Nickel plated
12	Retaining ring	Carbon tool steel	Nickel plated
13	Spacer	Rolled steel	Nickel plated
14	Bushing	Oil retaining bearing material	
15	Plate A	Aluminum alloy	Anodized
16	Plate B	Aluminum alloy	Anodized
17	Guide shaft A	Carbon steel	Hard chrome plated
18	Guide shaft B	Carbon steel	Hard chrome plated
19	Adjusting bolt A	Chromium molybdenum steel	
20	Adjusting bolt B	Chromium molybdenum steel	
21	Hexagon nut	Carbon steel	Nickel plated
22	Hexagon socket head cap screw	Chromium molybdenum steel	
23	Switch mounting rail	Aluminum alloy	

Note 1) Brass for $\phi 6$, $\phi 10$ and $\phi 15$.

Note 2) Piston nuts are not included for $\phi 6$, $\phi 10$ and $\phi 15$.

No.	Description	Material	Note
24	Auto switch	—	
25	Plug	Brass	
26*	Wear ring A	Special resin	
27*	Wear ring B	Special resin	
28*	Cylinder tube gasket	NBR	
29*	Guide shaft gasket	NBR	
30*	Piston seal	NBR	
31*	Scraper	NBR	

Replacement Parts: Seal Kit

Bore size (mm)	Kit no.	Contents
6	CY1S6-PS-N	Set of nos. above 27, 28, 29, 30
10	CY1S10-PS-N	Nos. above 26, 27, 28, 29, 30, 31
15	CY1S15-PS-N	
20	CY1S20-PS-N	
25	CY1S25-PS-N	
32	CY1S32-PS-N	
40	CY1S40-PS-N	

* Seal kit includes 27 to 30 for $\phi 6$. 26 to 31 are for $\phi 10$ to $\phi 40$. Order the seal kit, based on each bore size.

* Seal kit includes a grease pack ($\phi 6$, $\phi 10$: 5 and 10 g, $\phi 15$ to $\phi 40$: 10 g). Order with the following part number when only the grease pack is needed.
Grease pack part no. for $\phi 6$, $\phi 10$: GR-F-005 (5 g) for external sliding parts, GR-S-010 (10 g) for tube interior
Grease pack part no. for $\phi 15$ to $\phi 40$: GR-S-010 (10 g)

Magnetically Coupled Rodless Cylinder Slider Type: Slide Bearing **Series CY1S**

Dimensions

Slider type/Slide bearing

C□Y1S6/10

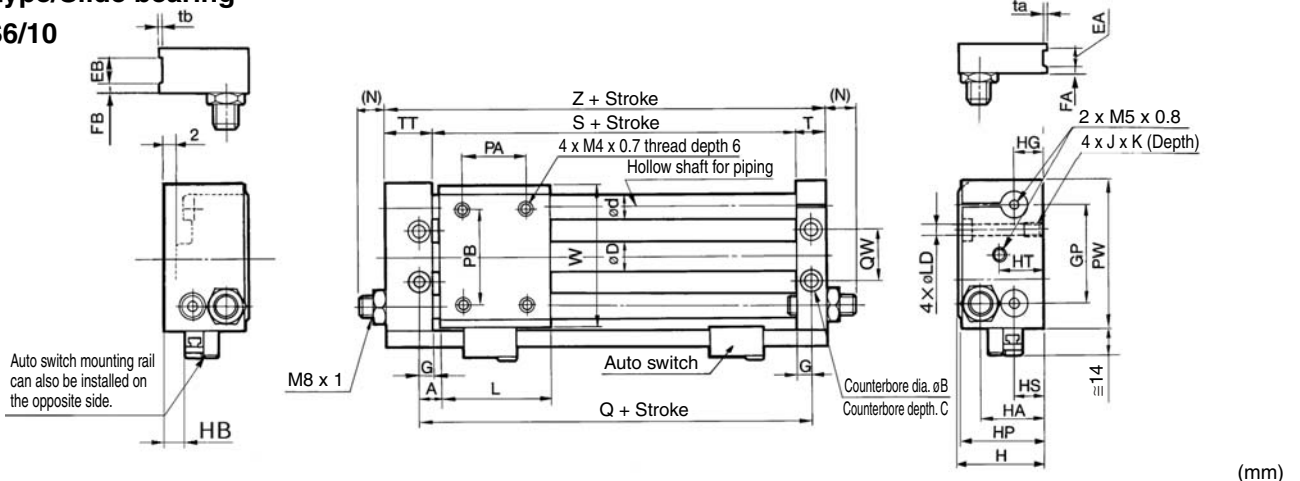

Model	A	B	C	D	d	EA	EB	FA	FB	G	GP	H	HA	HB*	HG	HP	HS	HT
CY1S6 CDY1S6	6	6.5	3	7.6	8	-	-	-	-	5	32	27	19	4	8	26	8	17
CY1S10 CDY1S10	7.5	8	4	12	10	6	12	3	5	6.5	40	34	25.5	10	12	33	14	18

Model	J x K	L	LD	(N)	PA*	PB	PW	Q	QW	S	T	TT	ta	tb	W	Z
CY1S6 CDY1S6	M4 x 0.7 x 6.5	40	3.5	11	25	25	50	52	16	42	10	16	-	-	46	68
CY1S10 CDY1S10	M5 x 0.8 x 9.5	45	4.3	10.5	25	38	60	60	24	47	12.5	20.5	0.5	1.0	58	80

* PA dimensions are for split from center. HB dimensions are for CDY1S.

C□Y1S15/ø20 to ø40

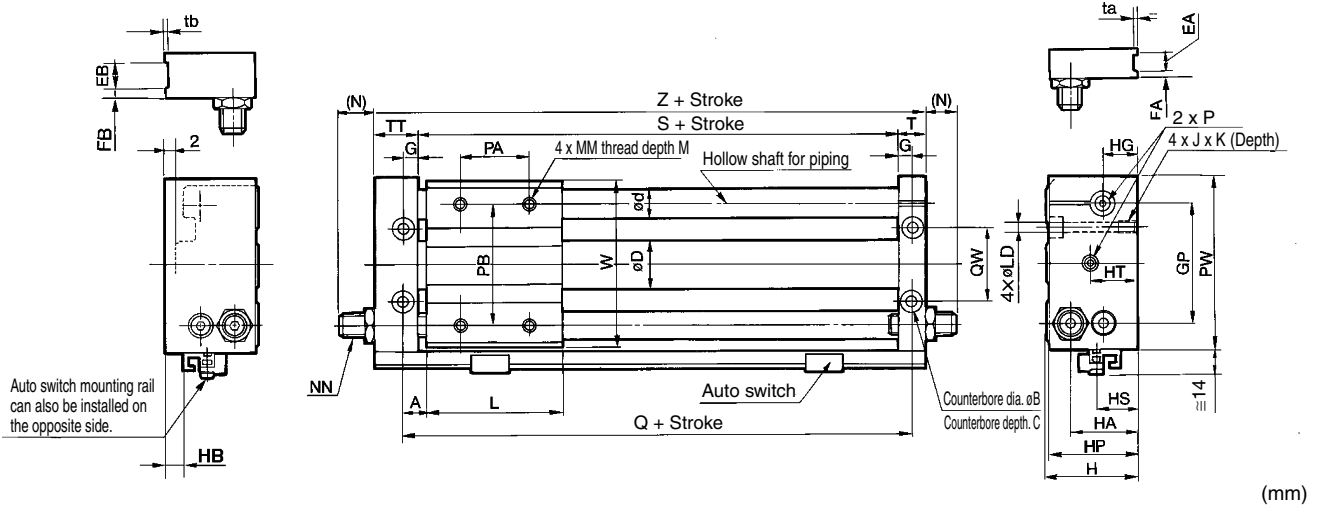

Model	A	B	C	D	d	EA	EB	FA	FB	G	GP	H	HA	HB*	HG	HP	HS	HT	J x K	L
CY1S15 CDY1S15	7.5	9.5	5	16.6	12	6	13	3	6	6.5	52	40	29	1	13	39	15	21	M6 x 1.0 x 9.5	60
CY1S20 CDY1S20	10	9.5	5.2	21.6	16	-	-	-	-	8.5	62	46	36	4.5	17	45	25.5	20	M6 x 1.0 x 9.5	70
CY1S25 CDY1S25	10	11	6.5	26.4	16	8	14	4	7	8.5	70	54	40	9	20	53	23	20	M8 x 1.25 x 10	70
CY1S32 CDY1S32	12.5	14	8	33.6	20	8	16	5	7	9.5	86	66	46	13	24	64	27	24	M10 x 1.5 x 15	85
CY1S40 CDY1S40	12.5	14	8	41.6	25	10	20	5	10	10.5	104	76	57	17	25	74	31	25	M10 x 1.5 x 15	95

Model	LD	M	MM	(N)	NN	P	PA*	PB	PW	Q	QW	S	T	TT	ta	tb	W	Z
CY1S15 CDY1S15	5.6	8	M5 x 0.8	8.5	M8 x 1.0	M5 x 0.8	30	50	75	75	30	62	12.5	22.5	0.5	1	72	97
CY1S20 CDY1S20	5.6	10	M6 x 1.0	10	M10 x 1.0	Rc1/8	40	70	90	90	38	73	16.5	25.5	-	-	87	115
CY1S25 CDY1S25	7	10	M6 x 1.0	12	M14 x 1.5	Rc1/8	40	70	100	90	42	73	16.5	25.5	0.5	1	97	115
CY1S32 CDY1S32	8.7	12	M8 x 1.25	11.5	M20 x 1.5	Rc1/8	40	75	122	110	50	91	18.5	28.5	0.5	1	119	138
CY1S40 CDY1S40	8.7	12	M8 x 1.25	11.5	M20 x 1.5	Rc1/4	65	105	145	120	64	99	20.5	35.5	1	1	142	155

* PA dimensions are for split from center. HB dimensions are for CDY1S.

- CY3B
- CY3R
- CY1S**
- CY1L
- CY1H
- CY1F
- CYP

- D-□
- X□
- Individual
- X□
- Technical data

Series CY1S

Dimensions: With Shock Absorber

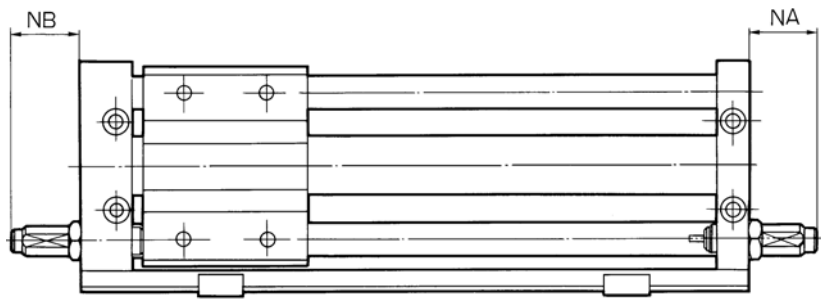

(mm)

Model	Applicable shock absorber	NA	NB
C□Y1S 6	RB0805	30	24
C□Y1S10		27	19
C□Y1S15		27	17
C□Y1S20	RB1006	29	20
C□Y1S25	RB1411	49.5	40.5
C□Y1S32	RB2015	52	42
C□Y1S40		51	36

Proper Auto Switch Mounting Position (Detection at stroke end)

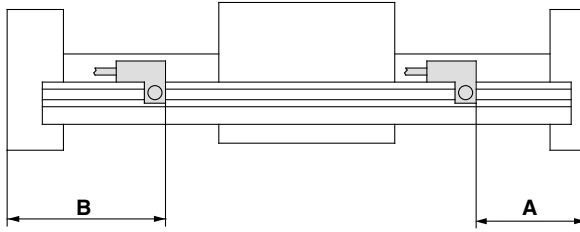

(mm)

Bore size (mm)	Applicable auto switch					
	D-A73, A80		D-A72/ A7□H/ A80H/ A73C/ D-A80C/ F7□/ J79/ F7□V/ J79C D-F7□W/ J79W/ F7□WV D-F7BAL/ F7BAVL/ D-F79F		D-F7NTL	
	A	B	A	B	A	B
6	27.5	40.5	28	40	33	35
10	35	45	35.5	44.5	40.5	39.5
15	34.5	62.5	35	62	40	57
20	64	50	64.5	49.5	69.5	44.5
25	44	71	44.5	70.5	49.5	65.5
32	55	83	55.5	82.5	60.5	77.5
40	61	94	61.5	93.5	66.5	88.5

Note 1) 50 mm is the minimum stroke available with 2 auto switches mounted. In the case of a stroke less than this, please contact SMC.

Note 2) Adjust the auto switch after confirming the operating conditions in the actual setting.

Operating Range

(mm)

Auto switch model	Bore size (mm)						
	6	10	15	20	25	32	40
D-A7□/ A8□	6	6	6	6	6	6	6
D-F7□/ J7□	3	3	4	3	3	3	3.5
D-F79F	4.5	4.5	4.5	4.5	4.5	4.5	4.5

* Since this is a guideline including hysteresis, not meant to be guaranteed.

(Assuming approximately ±30% dispersion)

There may be the case it will vary substantially depending on an ambient environment.

Other than the models listed in "How to Order", the following auto switches are applicable.
For detailed specifications, refer to page 1314.

Type	Model	Electrical entry (Fetching direction)	Features
Solid state auto switch	D-F7NTL	Grommet (In-line)	With timer

* With pre-wired connector is available for D-F7NTL type, too.
For details, refer to pages 1328 and 1329.

Mounting of Auto Switch

When mounting an auto switch, the auto switch mounting screw should be screwed into a hexagon nut (M3 x 0.5) which has been inserted into the groove of the switch mounting rail. (Tightening torque: Approx. 0.5 to 0.7 N·m.)

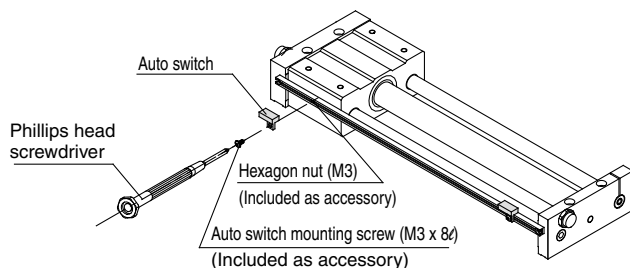

CY3B
CY3R

CY1S

CY1L

CY1H

CY1F

CYP

D-□

-X□

Individual

-X□

Technical data



Series CY1S Specific Product Precautions

Be sure to read before handling. Refer to front matters 54 and 55 for Safety Instructions and pages 3 to 11 for Actuator and Auto Switch Precautions.

Operation

Warning

- 1. Be aware of the space between the plates and the slide block.**
Take sufficient care to avoid getting your hands or fingers caught when the cylinder is operated.
- 2. Do not apply a load to a cylinder which is greater than the allowable value stated in the "Model Selection" pages.**
This may cause malfunctions.
- 3. When the cylinder is used in a place where water or cutting oil may splash or the lubrication condition on the cylinder sliding parts would be deteriorated, please consult SMC.**
- 4. When applying grease to the cylinder, use the grease that has already been applied to the product. Contact SMC for available grease packs.**

Mounting

Caution

- 1. Avoid operation with the external slider fixed to the mounting surface.**
The cylinder should be operated with the plates fixed to the mounting surface.
- 2. Make sure that the cylinder mounting surface is a flatness of 0.2 mm or less.**
If the flatness of the cylinder mounting surface is not appropriate, 2 guide shafts may be twisted. This may adversely affect the operating conditions and shorten the service life due to the increase of sliding resistance and the early abrasion of bearings.
The cylinder mounting surface must be a flatness of 0.2 mm or less, and the cylinder must be mounted as it smoothly operates through the full stroke at the minimum operating pressure (0.18 MPa or less).

Service Life and Replacement Period of Shock Absorber

Caution

- 1. Allowable operating cycle under the specifications set in this catalog is shown below.**
1.2 million times RB08□□
2 million times RB10□□ to RB2725
Note) Specified service life (suitable replacement period) is the value at room temperature (20 to 25°C).
The period may vary depending on the temperature and other conditions. In some cases the absorber may need to be replaced before the allowable operating cycle above.

Disassembly and Maintenance

Warning

- 1. Use caution as the attractive force of the magnets is very strong.**
When removing the external slider and piston slider from the cylinder tube for maintenance, etc., handle with caution, since the magnets installed in each slider have a very strong attractive force.

Caution

- 1. Use caution when removing the external slider, as the piston slider will be directly attracted to it.**
When removing the external slider or piston slider from the cylinder tube, first force the sliders out of their magnetically coupled positions, and then remove them individually when there is no longer any holding force. If they are removed while still magnetically coupled, they will be directly attracted to one another and will not come apart.
- 2. Since the magnetic holding force can be changed (for example, from CY1S25L to CY1S25H), please contact SMC if this is necessary.**
- 3. Do not disassemble the magnetic components (piston slider, external slider).**
This can cause a loss of holding force and malfunction.
- 4. When disassembling to replace the seals and wear ring, refer to the separate disassembly instructions.**
- 5. Use caution to the direction of the external slider and the piston slider.**
Since the external slider and piston slider are directional for $\phi 6$, $\phi 10$ and holding force type L, refer to the figures below when performing disassembly or maintenance. Put the external slider and piston slider together, and insert the piston slider into the cylinder tube so that they will have the correct positional relationship as shown in Fig. (1). If they align as shown in Fig. (2), insert the piston slider after turning it around 180°. If the direction is not correct, it will be impossible to obtain the specified holding force.

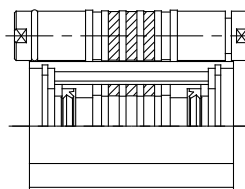

Fig. (1) Correct position

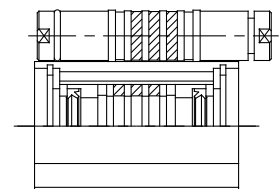

Fig. (2) Incorrect position

Example of $\phi 15$ with holding force type L

Slider Type/Ball Bushing Bearing

Series *CY1L*

ø6, ø10, ø15, ø20, ø25, ø32, ø40



CY3B
CY3R

CY1S

CY1L

CY1H

CY1F

CYP

D-□

-X□

Individual
-X□

Technical
data

Series CY1L Model Selection 1

E: Kinetic energy of load (J)

$$E = \frac{W}{2} \cdot \left(\frac{V}{1000}\right)^2$$

Es: Allowable kinetic energy for intermediate stop using an air pressure circuit (J)

Ps: Operating pressure limit for intermediate stop using an external stopper, etc. (MPa)

Pv: Maximum operating pressure for vertical operation (MPa)

W_A: Allowable load mass based on these operating conditions (kg)

W_v: Allowable load mass for vertical operation (kg)

F_A: Allowable drive resisting force at pusher (kg)

σ: Stroke coefficient

$$\sigma = \frac{\text{Load mass in stroke}}{\text{Maximum load mass}}$$

Operating Conditions

- W: Load mass (kg)
- V: Speed (mm/s)
- P: Operating pressure (MPa)
- Stroke (mm)
- L_o: Distance from slide block mounting surface to workpiece center of gravity (cm)
- Mode of operation (Horizontal, Inclined, Vertical)
- F: Drive resisting force (kg)

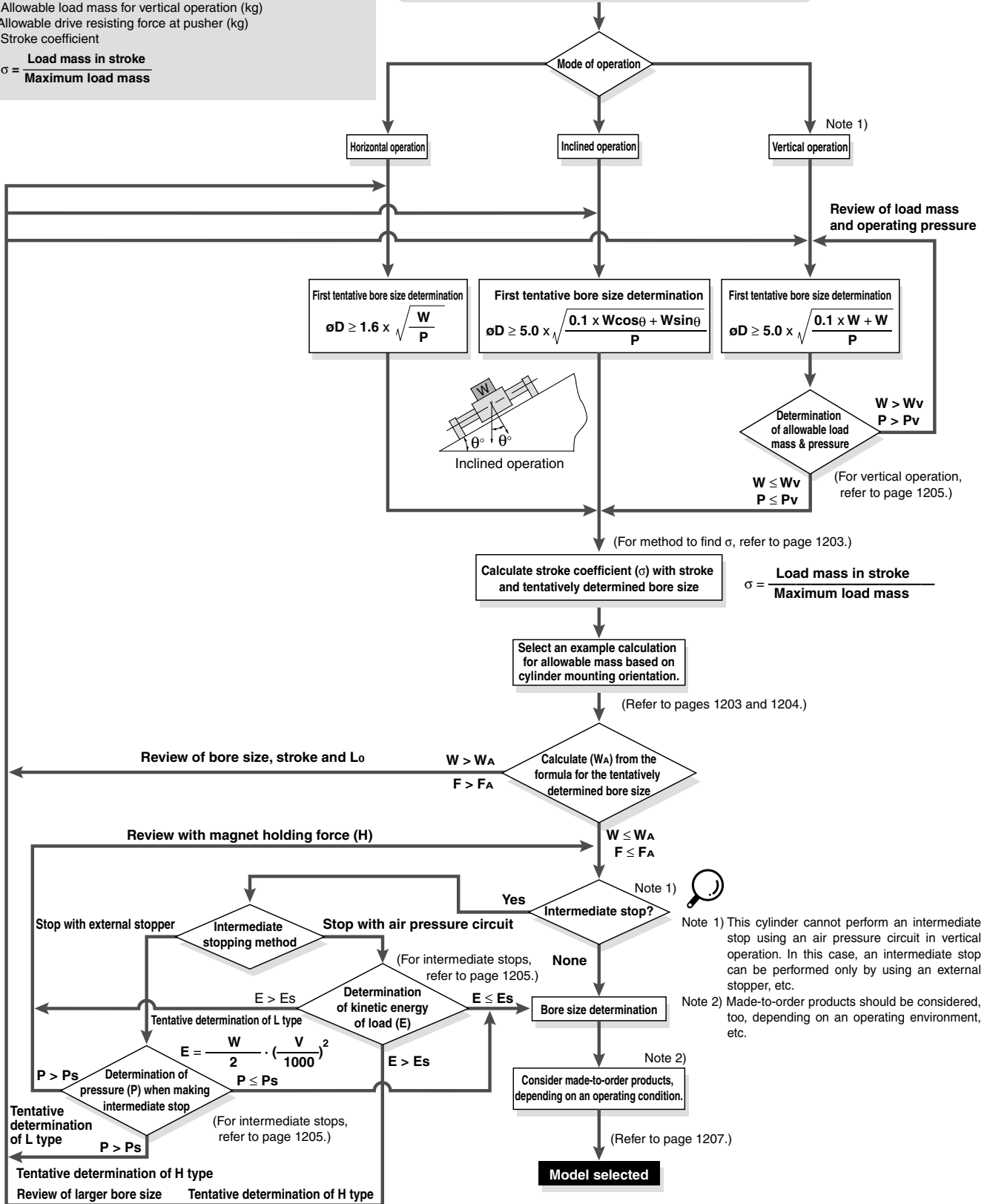

Determination of allowable load mass & pressure

W > W_v
P > P_v

W ≤ W_v
P ≤ P_v

(For vertical operation, refer to page 1205.)

$$\sigma = \frac{\text{Load mass in stroke}}{\text{Maximum load mass}}$$

Note 1) This cylinder cannot perform an intermediate stop using an air pressure circuit in vertical operation. In this case, an intermediate stop can be performed only by using an external stopper, etc.

Note 2) Made-to-order products should be considered, too, depending on an operating environment, etc.

Caution on Design (1)

How to Find σ when Selecting the Allowable Load Mass

Since the maximum load mass with respect to the cylinder stroke changes as shown in the table below, σ should be considered as a coefficient determined in accordance with each stroke.

Example) CY1L25□-650

- (1) Maximum load mass = 20 kg
- (2) Load mass for 650 st = 13.6 kg
- (3) $\sigma = \frac{13.6}{20} = 0.68$ is the result.

Calculation Formula for σ ($\sigma \leq 1$)

ST: Stroke (mm)

Model	CY1L6	CY1L10	CY1L15
$\sigma =$	1	$10^{\frac{(0.86 - 1.3 \times 10^{-3} \times \text{ST})}{3}}$	$10^{\frac{(1.5 - 1.3 \times 10^{-3} \times \text{ST})}{7}}$

Model	CY1L20	CY1L25	CY1L32
$\sigma =$	$10^{\frac{(1.71 - 1.3 \times 10^{-3} \times \text{ST})}{12}}$	$10^{\frac{(1.98 - 1.3 \times 10^{-3} \times \text{ST})}{20}}$	$10^{\frac{(2.26 - 1.3 \times 10^{-3} \times \text{ST})}{30}}$

Model	CY1L40
$\sigma =$	$10^{\frac{(2.48 - 1.3 \times 10^{-3} \times \text{ST})}{50}}$

Note) Calculate with $\sigma = 1$ for all applications up to $\phi 10 - 300$ mmST, $\phi 15 - 500$ mmST, $\phi 20 - 500$ mmST, $\phi 25 - 500$ mmST, $\phi 32 - 600$ mmST and $\phi 40 - 600$ mmST.

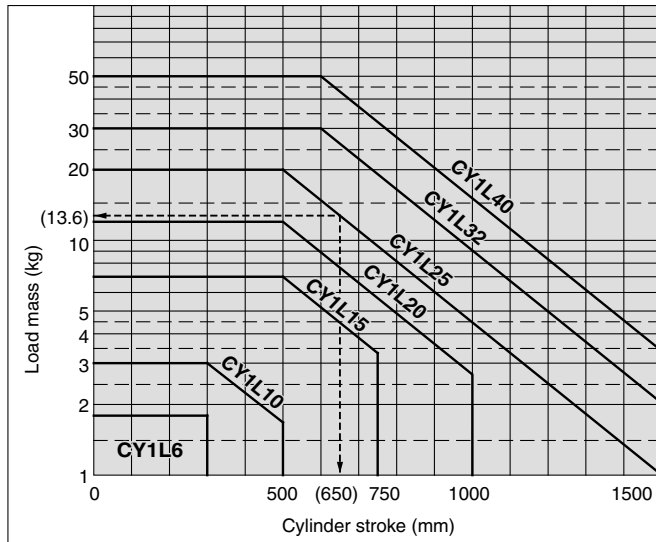

Examples of Allowable Load Mass Calculation Based on Cylinder Mounting Orientation

1. Horizontal Operation (Floor mounting)

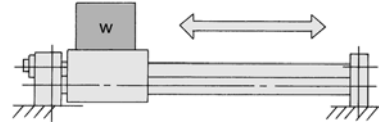

Maximum Load Mass (Center of slide block)

(kg)

Bore size (mm)	6	10	15	20	25	32	40
Max. load mass (kg)	1.8	3	7	12	20	30	50
Stroke (Max)	Up to 300 st	Up to 300 st	Up to 500 st	Up to 500 st	Up to 500 st	Up to 600 st	Up to 600 st

The above maximum load mass values will change with the stroke length for each cylinder size, due to limitation from warping of the guide shafts. (Take note of the coefficient σ .)

Moreover, depending on the operating direction, the allowable load mass may be different

2. Horizontal Operation (Wall mounting)

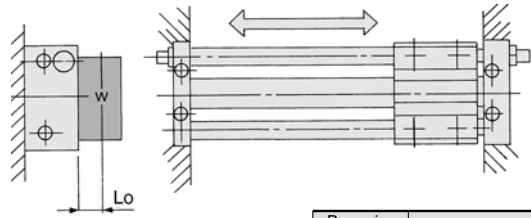

Lo: Distance from mounting surface to load center of gravity (cm)

Bore size (mm)	Allowable load mass (W _a) (kg)
6	$\frac{\sigma \cdot 6.48}{6.8 + 2Lo}$
10	$\frac{\sigma \cdot 15.0}{8.9 + 2Lo}$
15	$\frac{\sigma \cdot 45.5}{11.3 + 2Lo}$
20	$\frac{\sigma \cdot 101}{13.6 + 2Lo}$
25	$\frac{\sigma \cdot 180}{15.2 + 2Lo}$
32	$\frac{\sigma \cdot 330}{18.9 + 2Lo}$
40	$\frac{\sigma \cdot 624}{22.5 + 2Lo}$

3. Vertical Operation

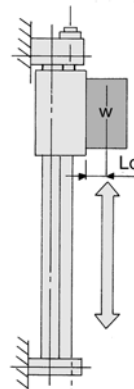

Bore size (mm)	Allowable load mass (W _v) (kg)
6	$\frac{\sigma \cdot 1.53}{1.6 + Lo}$
10	$\frac{\sigma \cdot 5.00}{1.95 + Lo}$
15	$\frac{\sigma \cdot 15.96}{2.4 + Lo}$
20	$\frac{\sigma \cdot 31.1}{2.8 + Lo}$
25	$\frac{\sigma \cdot 54.48}{3.1 + Lo}$
32	$\frac{\sigma \cdot 112.57}{3.95 + Lo}$
40	$\frac{\sigma \cdot 212.09}{4.75 + Lo}$

Lo: Distance from mounting surface to load center of gravity (cm)

Note) Operating pressure should be equal to or less than the maximum operating pressure in the article, "Vertical Operation" listed on page 1205.

CY3B
CY3R

CY1S

CY1L

CY1H

CY1F

CYP

D-□

-X□

Individual

-X□

Technical data

Caution on Design (2)

Example of Allowable Load Mass Calculation Based on Cylinder Mounting Orientation

4. Inclined Operation (In operating direction)

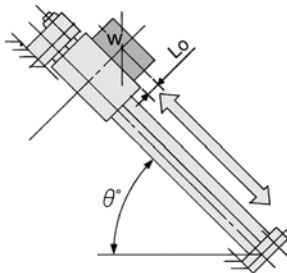

Angle	up to 45°	up to 60°	up to 75°	up to 90°
k	1	0.9	0.8	0.7

Angle coefficient (**k**) : $k = [\text{to } 45^\circ (= \theta)] = 1$,
 [to 60°] = 0.9, [to 75°] = 0.8,
 [to 90°] = 0.7

Lo: Distance from mounting surface to load center of gravity (cm)

Bore size (mm)	Allowable load mass (WA) (kg)
6	$\sigma \cdot 4.05 \cdot K$ $1.7 \cos \theta + 2 (1.6 + Lo) \sin \theta$
10	$\sigma \cdot 10.2 \cdot K$ $2.8 \cos \theta + 2 (1.95 + Lo) \sin \theta$
15	$\sigma \cdot 31.1 \cdot K$ $2.9 \cos \theta + 2 (2.4 + Lo) \sin \theta$
20	$\sigma \cdot 86.4 \cdot K$ $6 \cos \theta + 2 (2.8 + Lo) \sin \theta$
25	$\sigma \cdot 105.4 \cdot K$ $3.55 \cos \theta + 2 (3.1 + Lo) \sin \theta$
32	$\sigma \cdot 178 \cdot K$ $4 \cos \theta + 2 (3.95 + Lo) \sin \theta$
40	$\sigma \cdot 361.9 \cdot K$ $5.7 \cos \theta + 2 (4.75 + Lo) \sin \theta$

5. Inclined Operation (At a right angle to operating direction)

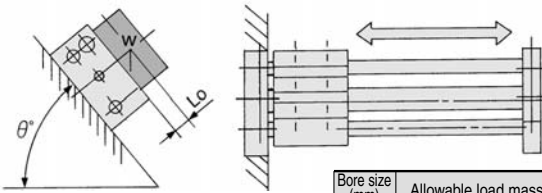

Lo: Distance from mounting surface to load center of gravity (cm)

Bore size (mm)	Allowable load mass (WA) (kg)
6	$\sigma \cdot 6.48$ $3.6 + 2 (1.6 + Lo) \sin \theta$
10	$\sigma \cdot 15$ $5 + 2 (1.95 + Lo) \sin \theta$
15	$\sigma \cdot 45.5$ $6.5 + 2 (2.4 + Lo) \sin \theta$
20	$\sigma \cdot 115$ $8 + 2 (2.8 + Lo) \sin \theta$
25	$\sigma \cdot 180$ $9 + 2 (3.1 + Lo) \sin \theta$
32	$\sigma \cdot 330$ $11 + 2 (3.95 + Lo) \sin \theta$
40	$\sigma \cdot 624$ $13 + 2 (4.75 + Lo) \sin \theta$

6. Load Center Offset in Operating Direction (Lo)

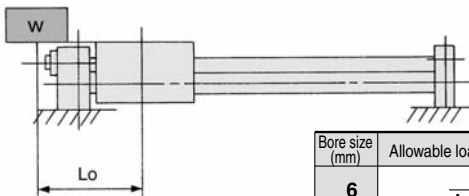

Lo: Distance from center of slide block to load's center of gravity (cm)

Bore size (mm)	Allowable load mass (WA) (kg)
6	$\frac{\sigma \cdot 2}{Lo + 1.7}$
10	$\frac{\sigma \cdot 5.6}{Lo + 2.8}$
15	$\frac{\sigma \cdot 13.34}{Lo + 2.9}$
20	$\frac{\sigma \cdot 43.2}{Lo + 6}$
25	$\frac{\sigma \cdot 46.15}{Lo + 3.55}$
32	$\frac{\sigma \cdot 80}{Lo + 4}$
40	$\frac{\sigma \cdot 188.1}{Lo + 5.7}$

7. Horizontal Operation (Pushing load, Pusher)

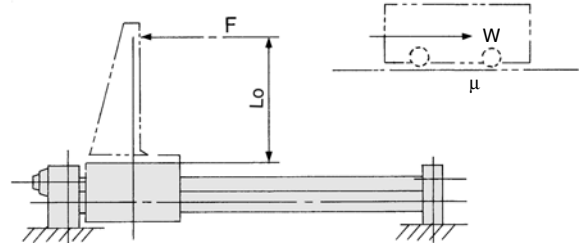

F: Drive (from slide block to position **Lo**) resistance force $W \times \mu$ (kg)
Lo: Distance from mounting surface to load center of gravity (cm)
 μ : Friction coefficient

Bore size (mm)	6	10	15	20
Allowable drive resisting force (FA) (kg)	$\frac{\sigma \cdot 2.72}{1.6 + Lo}$	$\frac{\sigma \cdot 5.55}{1.95 + Lo}$	$\frac{\sigma \cdot 15.96}{2.4 + Lo}$	$\frac{\sigma \cdot 41.7}{2.8 + Lo}$

Bore size (mm)	25	32	40
Allowable drive resisting force (FA) (kg)	$\frac{\sigma \cdot 58.9}{3.1 + Lo}$	$\frac{\sigma \cdot 106.65}{3.95 + Lo}$	$\frac{\sigma \cdot 228}{4.75 + Lo}$

8. Horizontal Operation (Load, Lateral offset Lo)

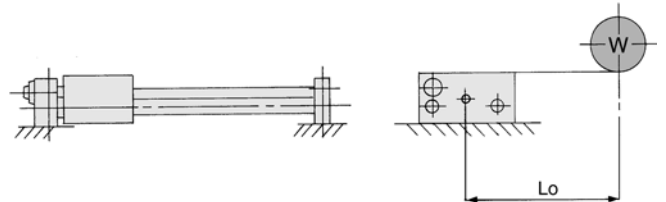

Lo: Distance from center of side block to load's center of gravity (cm)

Bore size (mm)	6	10	15	20
Allowable load mass (WA) (kg)	$\frac{\sigma \cdot 6.48}{3.6 + Lo}$	$\frac{\sigma \cdot 15}{5 + Lo}$	$\frac{\sigma \cdot 45.5}{6.5 + Lo}$	$\frac{\sigma \cdot 80.7}{8 + Lo}$

Bore size (mm)	25	32	40
Allowable load mass (WA) (kg)	$\frac{\sigma \cdot 144}{9 + Lo}$	$\frac{\sigma \cdot 275}{11 + Lo}$	$\frac{\sigma \cdot 520}{13 + Lo}$

Caution on Design (3)

Vertical Operation

When operating a load vertically, it should be operated within the allowable load mass and maximum operating pressures shown in the table below. Use caution, as operating above the prescribed values may lead to dropping of the load.

When the cylinder is mounted vertically or sidelong, sliders may move downwards due to the self-weight or workpiece mass. If an accurate stopping position is required at the stroke end or the middle-stroke, use an external stopper to secure accurate positioning.

Bore size (mm)	Model	Allowable load mass (Wv) (kg)	Maximum operating pressure (Pv) (MPa)
6	CY1L 6H	1.0	0.55
10	CY1L10H	2.7	0.55
15	CY1L15H	7.0	0.65
	CY1L15L	4.1	0.40
20	CY1L20H	11.0	0.65
	CY1L20L	7.0	0.40
25	CY1L25H	18.5	0.65
	CY1L25L	11.2	0.40
32	CY1L32H	30.0	0.65
	CY1L32L	18.2	0.40
40	CY1L40H	47.0	0.65
	CY1L40L	29.0	0.40

Note 1) Use caution, since the magnetic coupling may be dislocated if it is used over the maximum operating pressure.

Note 2) Allowable load mass above indicates the maximum load mass when loaded. The actual loadable mass must be determined referring to the flow chart in the Model Selection 1.

Intermediate Stop

1. Intermediate stopping of load with an external stopper, etc.

When stopping a load in mid-stroke using an external stopper (adjusting bolt, etc.), operate within the operating pressure limits shown in the table below. Use caution, as operation at a pressure exceeding these limits can result in breaking of the magnetic coupling.

Bore size (mm)	Model	Operating pressure limit for intermediate stop (Ps) (MPa)
6	CY1L 6H	0.55
10	CY1L10H	0.55
15	CY1L15H	0.65
	CY1L15L	0.40
20	CY1L20H	0.65
	CY1L20L	0.40
25	CY1L25H	0.65
	CY1L25L	0.40
32	CY1L32H	0.65
	CY1L32L	0.40
40	CY1L40H	0.65
	CY1L40L	0.40

2. Intermediate stopping of load with an air pressure circuit

When stopping a load using an air pressure circuit, operate at or below the kinetic energy shown in the table below. Use caution, as operation when exceeding the allowable value can result in breaking of the magnetic coupling.

(Reference values)

Bore size (mm)	Model	Allowable kinetic energy for intermediate stop (Es) (J)
6	CY1L 6H	0.007
10	CY1L10H	0.03
15	CY1L15H	0.13
	CY1L15L	0.076
20	CY1L20H	0.24
	CY1L20L	0.16
25	CY1L25H	0.45
	CY1L25L	0.27
32	CY1L32H	0.88
	CY1L32L	0.53
40	CY1L40H	1.53
	CY1L40L	0.95

CY3B
CY3R

CY1S

CY1L

CY1H

CY1F

CYP

D-□

-X□

Individual
-X□

Technical
data

Magnetically Coupled Rodless Cylinder Slider Type: Ball Bushing Bearing

Series *CY1L*

ø6, ø10, ø15, ø20, ø25, ø32, ø40

How to Order

Ball Bushing Bearing

CY1L 25 **H** - **300** - **J79W** -

Slider type
(Ball bushing bearing)

Bore size

6	6 mm	25	25 mm
10	10 mm	32	32 mm
15	15 mm	40	40 mm
20	20 mm		

Port thread type

Symbol	Type	Bore size
Nil	M thread	ø6, ø10, ø15
	Rc	ø20, ø25, ø32, ø40
TN	NPT	
TF	G	

Magnetic holding force

Refer to page 1207 for specifications.

Standard stroke

Refer to "Standard Stroke" on page 1207.

Made to Order
Refer to page 1207
for details.

Number of auto switches

Nil	2 pcs.
S	1 pc.
n	"n" pcs.

Auto switch

Nil	Without auto switch (Built-in magnet)
-----	---------------------------------------

* For the applicable auto switch model,
refer to the table below.

Adjustment type

Nil	With adjusting bolt
B	With shock absorbers (2 pcs.)
BS	With shock absorber (With plate A) * Installed on side A at time of shipment.

Applicable Auto Switch/Refer to pages 1263 to 1371 for further information on auto switches.

Type	Special function	Electrical entry	Indicator/light	Wiring (Output)	Load voltage		Auto switch model		Lead wire length (m) *				Pre-wired connector	Applicable load			
					DC	AC	Perpendicular	In-line	0.5 (Nil)	3 (L)	5 (Z)	None (N)		IC circuit	Relay, PLC		
Solid state switch	—	Grommet	Yes	3-wire (NPN)	5 V, 12 V	—	F7NV	F79	●	●	○	—	○	IC circuit	Relay, PLC		
				3-wire (PNP)			F7PV	F7P	●	●	○	—	○				
		Connector		2-wire	12 V		F7BV	J79	●	●	○	—	○				
	Diagnostic indication (2-color indication)	Grommet		3-wire (NPN)	24 V		5 V, 12 V	F7NWV	F79W	●	●	○	—			○	IC circuit
				3-wire (PNP)				—	F7PW	●	●	○	—			○	
		Water resistant (2-color indication)		2-wire	12 V		F7BWBV	J79W	●	●	○	—	○			—	
With diagnostic output (2-color indication)	4-wire (NPN)	5 V, 12 V	—	F79F	●	●	○	—	○	IC circuit							
Reed switch	—	Grommet	Yes	3-wire (NPN equivalent)	—	5 V	—	A76H	●	●	—	—	—	IC circuit	—		
				Connector	24 V	2-wire	12 V	100 V	A72	A72H	●	●	—	—	—	—	
		5 V, 12 V					100 V or less	A73	A73H	●	●	●	—	—	IC circuit		
		12 V					—	A80	A80H	●	●	—	—	—	IC circuit		
		5 V, 12 V					—	A73C	—	●	●	●	●	—	—	IC circuit	

* Lead wire length symbols: 0.5 m..... Nil (Example) J79W
3 m..... L (Example) J79WL
5 m..... Z (Example) J79WZ
None..... N (Example) J79CN

* Solid state auto switches marked with "○" are produced upon receipt of order.

- Since there are other applicable auto switches than listed, refer to page 1210 for details.
- For details about auto switches with pre-wired connector, refer to pages 1328 and 1329.
- * Auto switches are shipped together, (but not assembled).

Magnetically Coupled Rodless Cylinder Slider Type: Ball Bushing Bearing **Series CY1L**

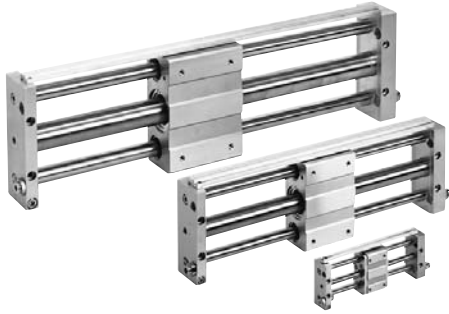

Easy piping and wiring

Hollow shafts are used, and centralization of ports on one side makes piping easy. Auto switches can be mounted through the use of special switch rails.

Shock absorbers and adjusting bolt are standard equipment

Impacts at stroke end due to high speed use can be absorbed, and fine adjustment of the stroke is possible.



Made to Order Specifications
(For details, refer to pages 1395 to 1565.)

Symbol	Specifications
—XB9	Low speed cylinder (15 to 50 mm/s)
—XB13	Low speed cylinder (7 to 50 mm/s)
—X116	Hydro specifications rodless cylinder
—X168	Helical insert thread specifications
—X322	Outside of cylinder tube with hard chrome plated

Amount of Adjustment by Adjusting Bolt

CY1L

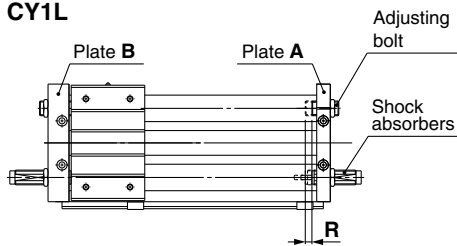

Bore size (mm)	Amount of adjustment by adjusting bolt: R(mm)	
	Single side	Both sides
6	6	12
10	5.5	11
15	3.5	7
20	5.5	11
25	5	10
32	5.5	11
40	4.5	9

* Since the cylinder is in an intermediate stop condition when stroke adjustment is performed, use caution regarding the operating pressure and the kinetic energy of the load.

* The amount of adjustment for adjustment bolts is the total amount when adjusted on both plate ends. For the adjustment on a single plate end, the amount of adjustment is half of the figures in the table above.

* Adjust the stroke adjustment with an adjustment bolt. It cannot be adjusted by a shock absorber.

Specifications

Bore size (mm)	6	10	15	20	25	32	40	
Fluid	Air							
Proof pressure	1.05 MPa							
Maximum operating pressure	0.7 MPa							
Minimum operating pressure	0.18 MPa							
Ambient and fluid temperature	-10 to 60°C							
Piston speed *	50 to 500 mm/s							
Cushion	Rubber bumper/Shock absorber							
Lubrication	Not required (Non-lube)							
Stroke length tolerance	0 to 250 st: $^{+1.0}_0$, 251 to 1000 st: $^{+1.4}_0$, 1001 st and up: $^{+1.8}_0$							
Holding force	Type H	19.6	53.9	137	231	363	588	922
	Type L	—	—	81.4	154	221	358	569
Standard equipment	Auto switch mounting rail							

* In the case of setting an auto switch at the intermediate position, the maximum piston speed is subject to restrict for detection upon the response time of a load (Relays, Sequence controller, etc.).

Standard Stroke

Bore size (mm)	Standard stroke (mm)	Maximum available stroke (mm)
6	50, 100, 150, 200	300
10	50, 100, 150, 200, 250, 300	500
15	50, 100, 150, 200, 250, 300, 350, 400, 450, 500	750
20	100, 150, 200, 250, 300, 350, 400, 450, 500, 600, 700, 800	1000
25		1500
32		1500
40	100, 150, 200, 250, 300, 350, 400, 450, 500, 600, 700, 800, 900, 1000	1500

Note) Intermediate stroke is available by the 1 mm interval.

Mass

Number of magnets	Bore size (mm)	(kg)						
		6	10	15	20	25	32	40
Basic mass	CY1L□H	0.324	0.580	1.10	1.85	2.21	4.36	4.83
	CY1L□L	—	—	1.02	1.66	2.04	4.18	4.61
Additional mass per each 50mm of stroke		0.044	0.077	0.104	0.138	0.172	0.267	0.406

Calculation

(Example) CY1L32H-500

• Basic mass 4.36 kg • Additional mass 0.267/50 st • Cylinder stroke 500 st
4.36 + 0.267 x 500 ÷ 50 = 7.03 kg

Shock Absorber Specifications

Refer to the Series RB in Best Pneumatics No. 3 for the details on shock absorbers.

Applicable rodless cylinder	6 CY1L10 15	CY1L20	CY1L25	32 40 CY1L	
Shock absorber model	RB0805	RB1006	RB1411	RB2015	
Maximum energy absorption: (J)	0.98	3.92	14.7	58.8	
Stroke absorption: (mm)	5	6	11	15	
Collision speed: (m/s)	0.05 to 5				
Max. operating frequency: (cycle/min) *	80	70	45	25	
Ambient temperature range	-10 to 80 °C				
Spring force: (N)	Extended	1.96	4.22	6.86	8.34
	Retracted	3.83	6.18	15.3	20.50

* It denotes the values at the maximum energy absorption per one cycle. Therefore, the operating frequency can be increased according to the energy absorption.

The shock absorber service life is different from that of the CY1L cylinder. Refer to the Specific Product Precautions for the replacement period.

Series CY1L

Construction

Slider type/Ball bushing bearing

CY1L6

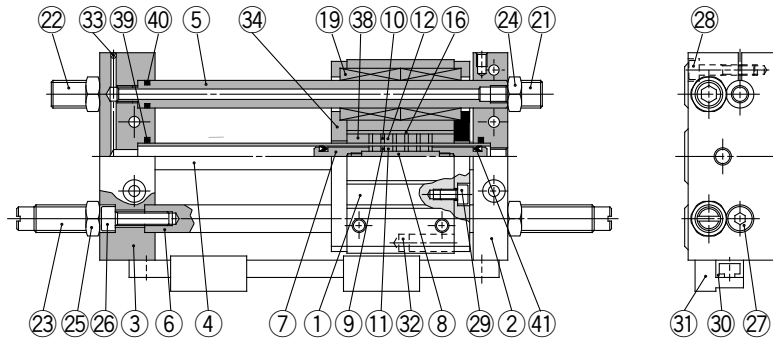

CY1L10 to 40

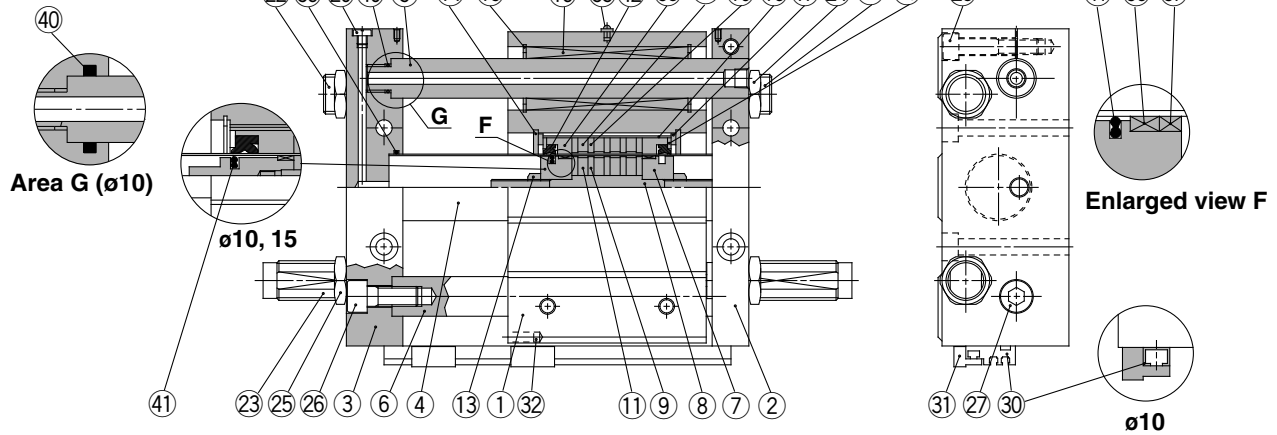

Component Parts

No.	Description	Material	Note
1	Slide block	Aluminum alloy	Anodized
2	Plate A	Aluminum alloy	Anodized
3	Plate B	Aluminum alloy	Anodized
4	Cylinder tube	Stainless steel	
5	Guide shaft A	Carbon steel	Hard chrome plated
6	Guide shaft B	Carbon steel	Hard chrome plated
7	Piston	Aluminum alloy ^{Note 1)}	Chromated
8	Shaft	Stainless steel	
9	Piston side yoke	Rolled steel	Zinc chromated
10	External slider side yoke	Rolled steel	Zinc chromated
11	Magnet A	—	
12	Magnet B	—	
13	Piston nut	Carbon steel	Zinc chromated ø25 to ø40
14	Retaining ring	Carbon tool steel	Nickel plated
15	Retaining ring	Carbon tool steel	Nickel plated
16	External slider tube	Aluminum alloy	
17	Slider spacer	Rolled steel	Nickel plated
18	Spacer	Rolled steel	Nickel plated
19	Ball bushing	—	
20	Plug	Brass	ø25, ø32, ø40 only
21	Adjusting bolt A	Chromium molybdenum steel	Nickel plated
22	Adjusting bolt B	Chromium molybdenum steel	Nickel plated
23	Shock absorber	—	
24	Hexagon nut	Carbon steel	Nickel plated
25	Hexagon nut	Carbon steel	Nickel plated
26	Hexagon socket head cap screw	Chromium molybdenum steel	Nickel plated
27	Hexagon socket head cap screw	Chromium molybdenum steel	Nickel plated
28	Hexagon socket head cap screw	Chromium molybdenum steel	Nickel plated

Note 1) Brass for ø6, ø10 and ø15

No.	Description	Material	Note
29	Hexagon socket head cap screw	Chromium molybdenum steel	Nickel plated
30	Switch mounting rail	Aluminum alloy	
31	Auto switch	—	
32	Magnet for auto switch	—	
33	Steel ball	—	ø6, ø10, ø15 only
34	Side cover	Carbon steel	ø6 only
35	Grease cup	Carbon steel	ø15 or larger
36*	Wear ring A	Special resin	
37*	Wear ring	Special resin	
38*	Wear ring B	Special resin	
39*	Cylinder tube gasket	NBR	
40*	Guide shaft gasket	NBR	
41*	Piston seal	NBR	
42*	Scraper	NBR	

Replacement Parts: Seal Kit

Bore size (mm)	Kit no.	Contents
6	CY1S6-PS-N	Set of nos. above 38, 39, 40, 41
10	CY1L10-PS-N	Set of nos. above 36, 38, 39, 40, 41, 42
15	CY1L15-PS-N	
20	CY1L20-PS-N	Set of nos. above 36, 37, 38, 39, 40, 41, 42
25	CY1L25-PS-N	
32	CY1L32-PS-N	
40	CY1L40-PS-N	

* Seal kit includes 38, 39, 40, 41 for ø6. 36, 38 to 42 are for ø10, ø15. 36 to 42 are for ø20 to ø40. Order the seal kit, based on each bore size.

* ø6: Same for CY1S6

* Seal kit includes a grease pack (ø6, ø10: 5 and 10 g, ø15 to ø40: 10 g). Order with the following part number when only the grease pack is needed.

Grease pack part no. for ø6, ø10: GR-F-005 (5 g) for external sliding parts,

GR-S-010 (10 g) for tube interior

Grease pack part no. for ø15 to ø40: GR-S-010 (10 g)

Magnetically Coupled Rodless Cylinder Slider Type: Ball Bushing Bearing **Series CY1L**

Dimensions

Slider type/Ball bushing bearing

CY1L6/10

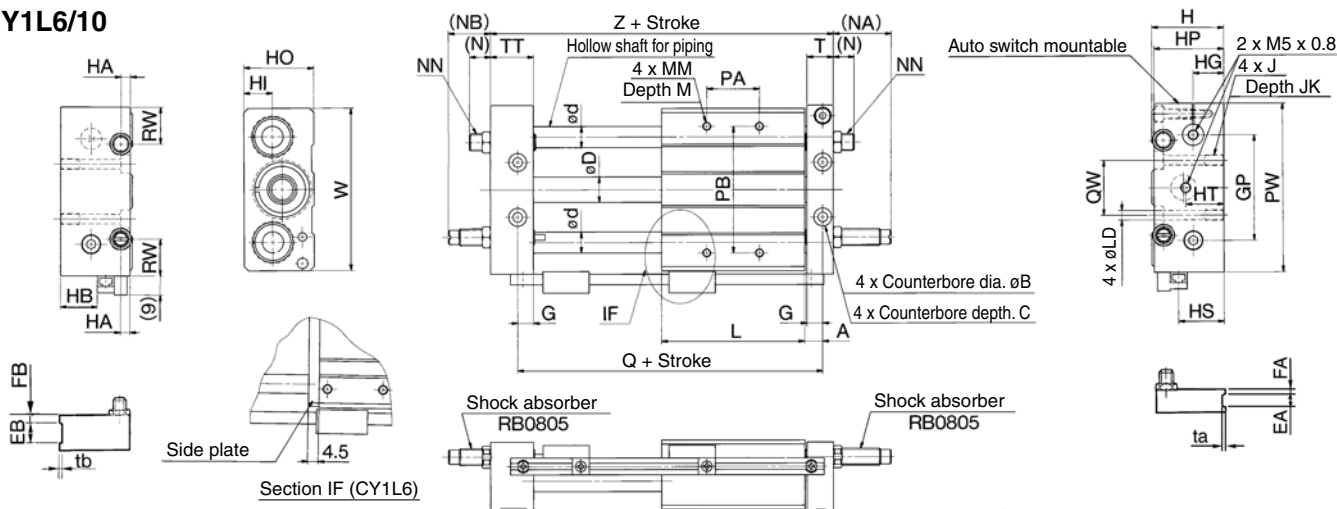

Model	A	B	C	D	d	EA	EB	FA	FB	G	GP	H	HA	HB	HG	HI	HO	HP	HS	HT	J	JK
CY1L6	7	6.5	3	7.6	8	—	—	—	—	6	36	27	6	10	11	9	25	26	14	16	M4 x 0.7	6.5
CY1L10	8.5	8	4	12	10	6	12	3	5	7.5	50	34	6	17.5	14.5	13.5	33	33	21.5	18	M5 x 0.8	9.5

Model	L	LD	M	MM	(N)	(NA)	(NB)	NN	PA*	PB	PW	Q	QW	RW	T	TT	ta	tb	W	Z
CY1L6	40	3.5	6	M4 x 0.7	11	30	24	M8 x 1.0	24	40	60	54	20	12	10	16	—	—	56	68
CY1L10	68	4.3	8	M4 x 0.7	10.5	27	19	M8 x 1.0	30	60	80	85	26	17.5	12.5	20.5	0.5	1.0	77	103

* PA dimensions are for split from center.

CY1L15/20/25/32/40

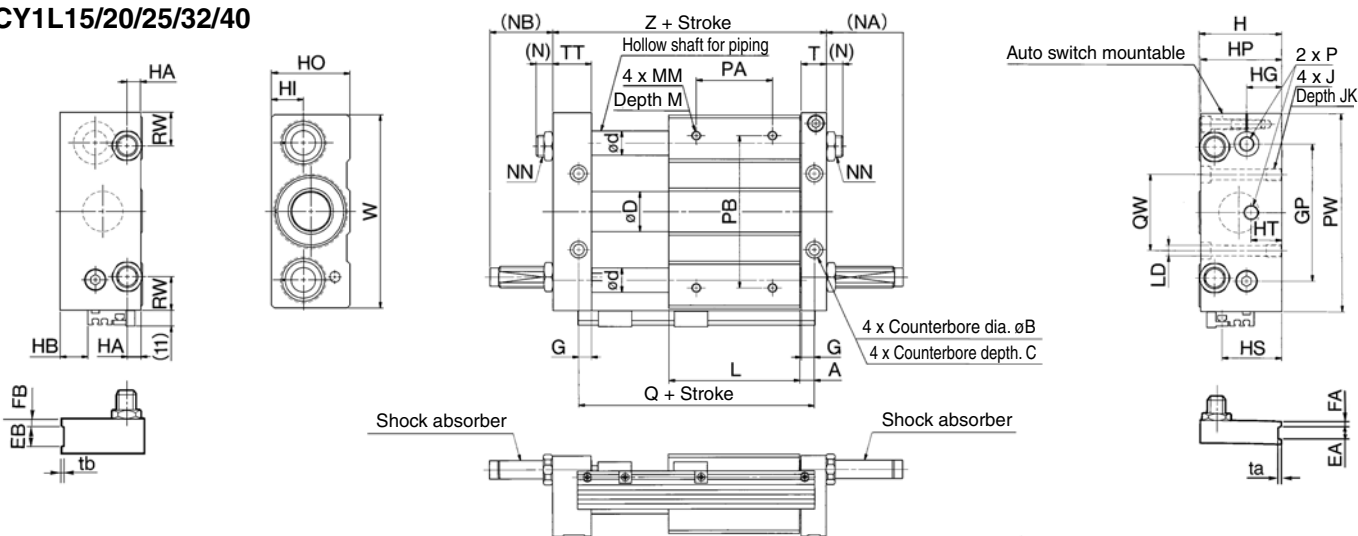

Model	A	B	C	D	d	EA	EB	FA	FB	G	GP	H	HA	HB	HG	HI	HO	HP	HS	HT	J	JK	L	LD
CY1L15	7.5	9.5	5	16.6	12	6	13	3	6	6.5	65	40	6.5	4	16	14	38	39	25	16	M6 x 1.0	9.5	75	5.6
CY1L20	9.5	9.5	5.2	21.6	16	—	—	—	—	8.5	80	46	9	10	18	16	44	45	31	20	M6 x 1.0	10	86	5.6
CY1L25	9.5	11	6.5	26.4	16	8	14	4	7	8.5	90	54	9	18	23	21	52	53	39	20	M8 x 1.25	10	86	7
CY1L32	10.5	14	8	33.6	20	8	16	5	7	9.5	110	66	12	26.5	26.5	24.5	64	64	47.5	25	M10 x 1.5	15	100	9.2
CY1L40	11.5	14	8	41.6	25	10	20	5	10	10.5	130	78	12	35	30.5	28.5	76	74	56	30	M10 x 1.5	15	136	9.2

Model	M	MM	(N)	(NA)	(NB)	NN	P	PA*	PB	PW	Q	QW	RW	T	ta	tb	TT	W	Z	Shock absorber
CY1L15	8	M5 x 0.8	8.5	27	17	M8 x 1.0	M5 x 0.8	45	70	95	90	30	15	12.5	0.5	1.0	22.5	92	112	RB0805
CY1L20	10	M6 x 1.0	10.5	29	20	M10 x 1.0	Rc 1/8	50	90	120	105	40	28	16.5	—	—	25.5	117	130	RB1006
CY1L25	10	M6 x 1.0	12.5	49	40	M14 x 1.5	Rc 1/8	60	100	130	105	50	22	16.5	0.5	1.0	25.5	127	130	RB1411
CY1L32	12	M8 x 1.25	13.5	52	42	M20 x 1.5	Rc 1/8	70	120	160	121	60	33	18.5	0.5	1.0	28.5	157	149	RB2015
CY1L40	12	M8 x 1.25	12.5	51	36	M20 x 1.5	Rc 1/4	90	140	190	159	84	35	20.5	1.0	1.0	35.5	187	194	RB2015

* PA dimensions are for split from center.

- CY3B
- CY3R
- CY1S
- CY1L**
- CY1H
- CY1F
- CYP

- D-□
- X□
- Individual
- X□
- Technical data

Series CY1L

Proper Auto Switch Mounting Position (Detection at stroke end)

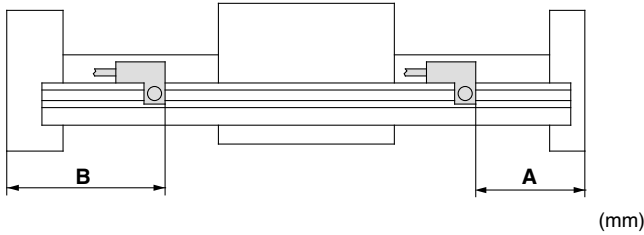

Bore size (mm)	Applicable auto switch					
	D-A73/A80		D-A72 □ D-A7□H/A80H D-A73C/A80C D-F7□/J79 D-F7□V/J79C D-F7□W/J79W D-F7□WV D-F7BAL/F7BAVL D-F79F		D-F7NTL	
	A	B	A	B	A	B
6	23□	45□	23.5□	44.5□	28.5□	39.5□
10	58□	45□	58.5□	44.5□	63.5□	39.5□
15	65□	47□	65.5□	46.5□	70.5□	41.5□
20	76□	54□	76.5□	53.5□	81.5□	48.5□
25	76□	54□	76.5□	53.5□	81.5□	48.5□
32	92□	57□	92.5□	56.5□	97.5□	51.5□
40	130	64	130.5	63.5	135.5	58.5

Note 1) 50 mm is the minimum stroke available with 2 auto switches mounted.
In the case of a stroke less than this, please contact SMC.□

Note 2) Adjust the auto switch after confirming the operating conditions in the actual setting.

Mounting of Auto Switch

When mounting an auto switch, the auto switch mounting screw should be screwed into a hexagon nut (M3 x 0.5) which has been inserted into the groove of the switch mounting rail. (Tightening torque: Approx. 0.5 to 0.7 N·m)

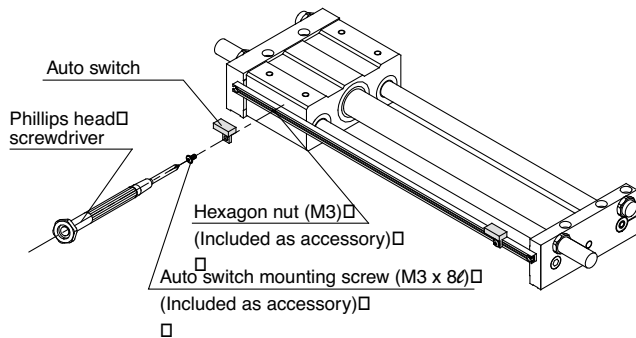

Operating Range

Auto switch model□	Bore size (mm)						
	6	10	15	20	25	32	40
D-A7□/A8□	6□	6□	6□	6□	6□	6□	6□
D-F7□/J7□	3□	3□	4□	3□	3□	3□	3.5□
D-F79F	4.5	4.5	4.5	4.5	4.5	4.5	4.5

* Since this is a guideline including hysteresis, not meant to be guaranteed. (Assuming approximately ±30% dispersion)□
There may be the case it will vary substantially depending on an ambient environment.□

Other than the models listed in “How to Order”, the following auto switches are applicable.□
For detailed specifications, refer to page 1314.

Type□	Model□	Electrical entry□ (Fetching direction)□	Features□
Solid state auto switch□	D-F7NTL□	Grommet □ (In-line)□	With timer□

* With pre-wired connector is available for D-F7NTL type, too. □
For details, refer to pages 1328 and 1329.□



Series CY1L Specific Product Precautions

Be sure to read before handling. Refer to front matters 54 and 55 for Safety Instructions and pages 3 to 11 for Actuator and Auto Switch Precautions.

Operation

Warning

- 1. Be aware of the space between the plates and the slide block.**
Take sufficient care to avoid getting your hands or fingers caught when the cylinder is operated.
- 2. Do not apply a load to a cylinder which is greater than the allowable value stated in the "Model Selection" pages.**
This may cause malfunctions.
- 3. When the cylinder is used in a place where water or cutting oil may splash or the lubrication condition on the cylinder sliding parts would be deteriorated, please consult with SMC.**
- 4. When applying grease to the cylinder, use the grease that has already been applied to the product. Contact SMC for available grease packs.**

Mounting

Caution

- 1. Avoid operation with the external slider fixed to the mounting surface.**
The cylinder should be operated with the plates fixed to the mounting surface.
- 2. Make sure that the cylinder mounting surface is a flatness of 0.2 mm or less.**
If the flatness of the cylinder mounting surface is not appropriate, 2 guide shafts may be twisted. This may adversely affect the operating conditions and shorten the service life due to the increase of sliding resistance and the early abrasion of bearings.
The cylinder mounting surface must be a flatness of 0.2 mm or less, and the cylinder must be mounted as it smoothly operates through the full stroke at the minimum operating pressure (0.18 MPa or less).

Service Life and Replacement Period of Shock Absorber

Caution

- 1. Allowable operating cycle under the specifications set in this catalog is shown below.**
1.2 million times RB08□□
2 million times RB10□□ to RB2725
Note) Specified service life (suitable replacement period) is the value at room temperature (20 to 25°C).
The period may vary depending on the temperature and other conditions. In some cases the absorber may need to be replaced before the allowable operating cycle above.

Disassembly and Maintenance

Warning

- 1. Use caution as the attractive power of the magnets is very strong.**
When removing the external slider and piston slider from the cylinder tube for maintenance, etc., handle with caution, since the magnets installed in each slider have a very strong attractive force.

Caution

- 1. Use caution when removing the external slider, as the piston slider will be directly attracted to it.**
When removing the external slider or piston slider from the cylinder tube, first force the sliders out of their magnetically coupled positions, and then remove them individually when there is no longer any holding force. If they are removed while still magnetically coupled, they will be directly attracted to one another and will not come apart.
- 2. Since the magnetic holding force can be changed (for example, from CY1L25L to CY1L25H), please contact SMC if this is necessary.**
- 3. Do not disassemble the magnetic components (piston slider, external slider).**
This can cause a loss of holding force and malfunction.
- 4. When disassembling to replace the seals and wear ring, refer to the separate disassembly instructions.**
- 5. Use caution to the direction of the external slider and the piston slider.**
Since the external slider and piston slider are directional for $\phi 6$, $\phi 10$ and holding force type L, refer to the figures below when performing disassembly or maintenance. Put the external slider and piston slider together, and insert the piston slider into the cylinder tube so that they will have the correct positional relationship as shown in Fig. (1). If they align as shown in Fig. (2), insert the piston slider after turning it around 180°. If the direction is not correct, it will be impossible to obtain the specified holding force.

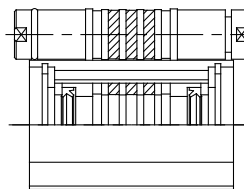

Fig. (1) Correct position

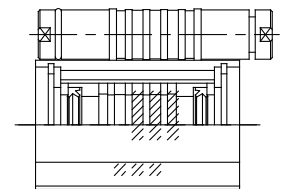

Fig. (2) Incorrect position

Example of $\phi 15$ with holding force type L

CY3B
CY3R

CY1S

CY1L

CY1H

CY1F

CYP

D-□

-X□

Individual
-X□

Technical
data

Linear Guide Type

Series *CY1H*

Single axis type: $\varnothing 10$, $\varnothing 15$, $\varnothing 20$, $\varnothing 25$

Double axes type: $\varnothing 25$, $\varnothing 32$

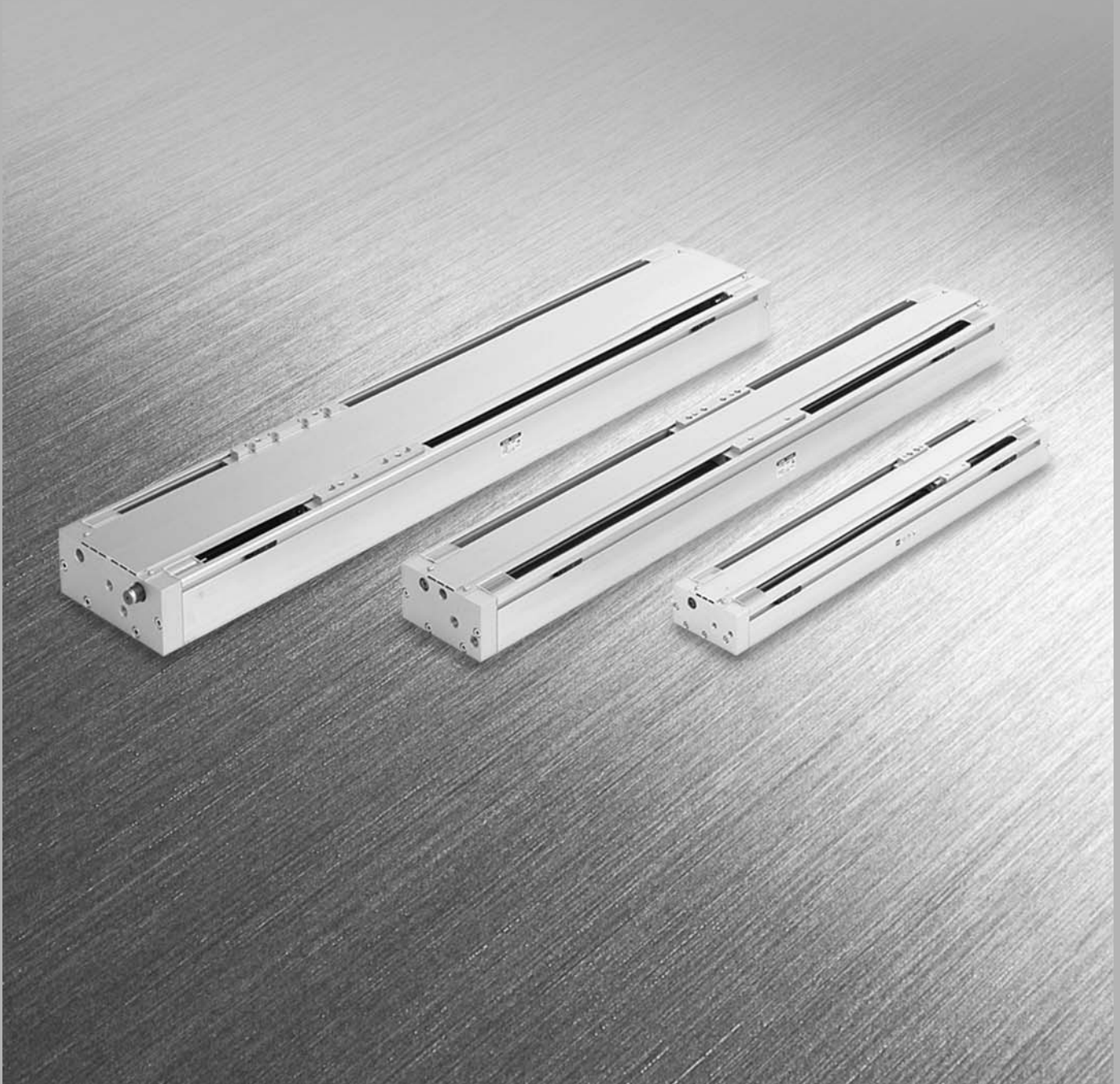

CY3B
CY3R

CY1S

CY1L

CY1H

CY1F

CYP

D-□

-X□

Individual
-X□

Technical
data

Series CY1H Model Selection 1

E: Kinetic energy of load (J)

$$E = \frac{W}{2} \cdot \left(\frac{V}{1000} \right)^2$$

Es: Allowable kinetic energy for intermediate stop using an air pressure circuit (J)

Ps: Operating pressure limit for intermediate stop using an external stopper, etc. (MPa)

Pv: Maximum operating pressure for vertical operation (MPa)

Wv: Allowable load mass for vertical operation (kg)

α: Load factor

$$\sum \alpha = \frac{\text{Load mass (W)}}{\text{Max. load mass (Wmax)}} + \frac{\text{Static moment (M)}}{\text{Allowable static moment (Mmax)}} + \frac{\text{Dynamic moment (Me)}}{\text{Allowable dynamic moment (Memax)}}$$

Operating Conditions

- W: Load mass (kg)
- V: Speed (mm/s)
- P: Operating pressure (MPa)
- Stroke (mm)
- Position of workpiece center of gravity (m)
- Mode of operation (Horizontal, Inclined, Vertical)

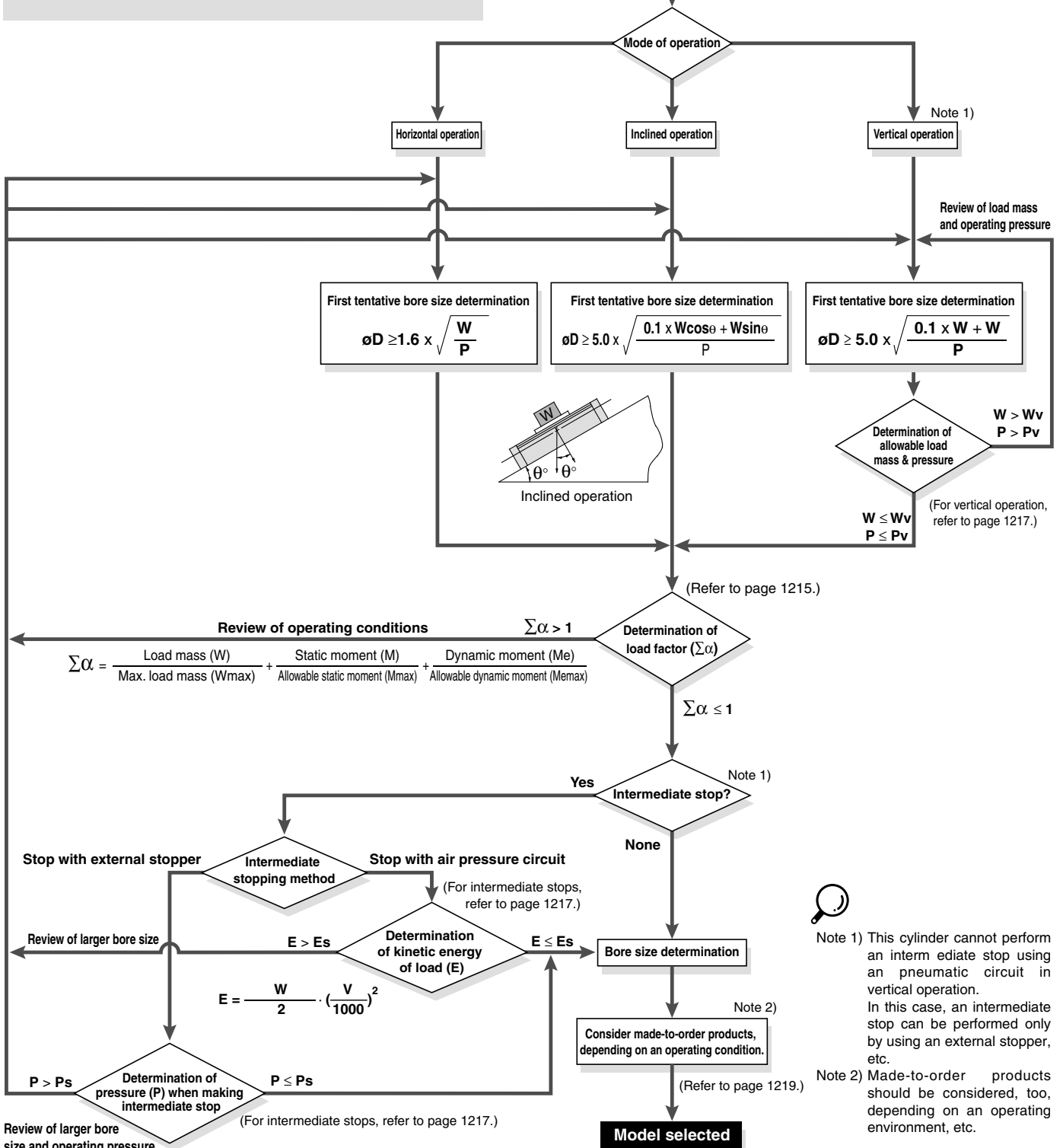

Note 1) This cylinder cannot perform an intermediate stop using an pneumatic circuit in vertical operation. In this case, an intermediate stop can be performed only by using an external stopper, etc.

Note 2) Made-to-order products should be considered, too, depending on an operating environment, etc.

Review of larger bore size and operating pressure

Series CY1H

Model Selection 2

Caution on Design (1)

The maximum load mass and allowable moment will differ depending on the workpiece mounting method, cylinder mounting orientation and piston speed. A determination of usability is performed based on the operating limit values in the graphs with respect to operating conditions, but the total ($\Sigma \alpha_n$) of the load factors (α_n) for each mass and moment should not exceed 1.

$$\Sigma \alpha_n = \frac{\text{Load mass (W)}}{\text{Maximum load mass (W max)}} + \frac{\text{Static moment (M)}}{\text{Allowable static moment (M max)}} + \frac{\text{Dynamic moment (Me)}}{\text{Allowable dynamic moment (Me max)}} \leq 1$$

Wmax, Mmax and Me max values are according to graph (1), (2) and (3) below.

Load Mass

Maximum Load Mass

Model	W _{max} (kg)
CY1H10	4.0
CY1H15	9.0
CY1H20	16.0
CY1H25	25.0
CY1HT25	
CY1HT32	40.0

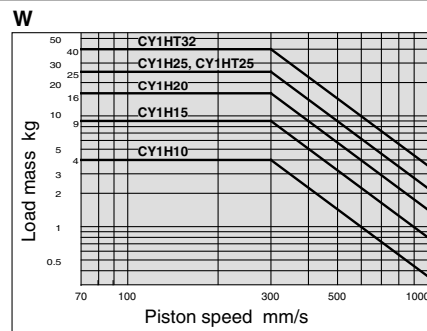
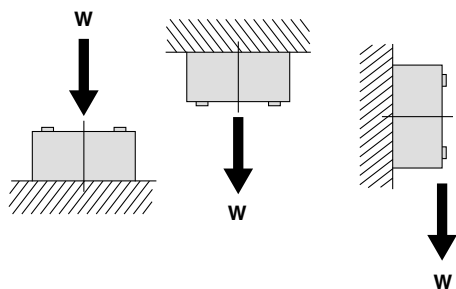

Graph (1)

Moment

Allowable Moment (Static moment/Dynamic moment)

Model	M1	M2	M3
CY1H10	1.5	2.5	1.5
CY1H15	10	16	10
CY1H20	13	16	13

Model	M1	M2	M3
CY1H25	28	26	28
CY1HT25	56	85	56
CY1HT32	64	96	64

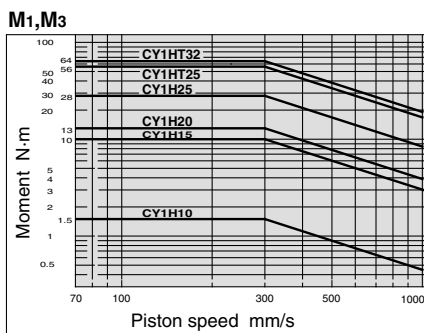
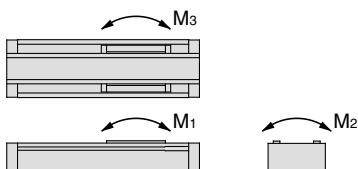

Graph (2)

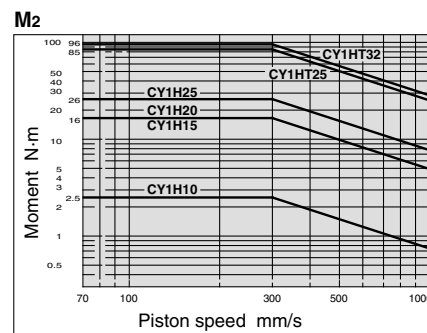

Graph (3)

Static Moment

Moment generated by the workpiece weight even when the cylinder is stopped

■ Pitch moment
M₁ = W · L

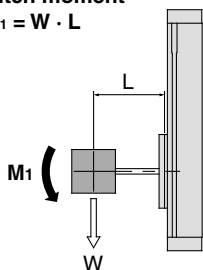

■ Roll moment
M₂ = W · L

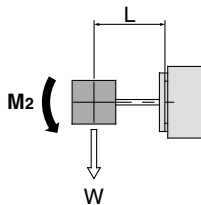

■ Yaw moment
M₃ = W (L - A)

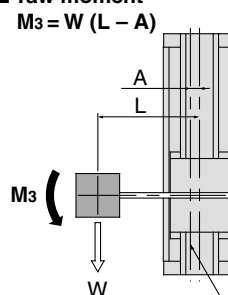

(mm)

Model	A
CY1H10	15
CY1H15	17.5
CY1H20	19.5
CY1H25	23.5
CY1HT25	0*
CY1HT32	0*

* Since there are 2 guides, the guides' central axis and the cylinder's central axis are the same.

Dynamic Moment

Moment generated by the load equivalent to impact at the stroke end

$$We = \delta \cdot W \cdot V$$

$$V = 1.4 Va$$

We: Load equivalent to impact [N]
 δ : Bumper coefficient
 With adjusting bolt (standard) = 4/100
 With shock absorber = 1/100

W: Load mass [kg]
 V: Collision speed [mm/s]
 Va: Average speed [mm/s]

■ Pitch moment
Me₁ = 1/3* · We · L

* Average load coefficient

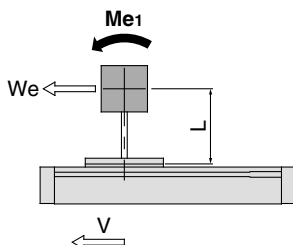

■ Yaw moment
Me₃ = 1/3* · We (L - A)

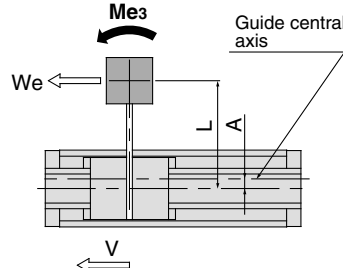

(mm)

Model	A
CY1H10	15
CY1H15	17.5
CY1H20	19.5
CY1H25	23.5
CY1HT25	0*
CY1HT32	0*

* Since there are 2 guides, the guides' central axis and the cylinder's central axis are the same.

CY3B
CY3R
CY1S
CY1L
CY1H
CY1F
CYP

D-□
-X□
Individual
-X□
Technical
data

Series CY1H

Model Selection 3

Selection Calculation

The selection calculation finds the load factors (α_n) of the items below, where the total ($\Sigma\alpha_n$) does not exceed 1.

$$\Sigma\alpha_n = \alpha_1 + \alpha_2 + \alpha_3 \leq 1$$

Item	Load factor α_n	Note
1. Max. load mass	$\alpha_1 = W/W_{\max}$	Examine W . W_{max} is the max. load mass for V_a .
2. Static moment	$\alpha_2 = M/M_{\max}$	Examine M₁ , M₂ , M₃ . M_{max} is the allowable moment for V_a .
3. Dynamic moment	$\alpha_3 = Me/M_{\max}$	Examine Me₁ , Me₃ . Me_{max} is the allowable moment for V .

V : Collision speed **V_a** : Average speed

Calculation Example

Operating Conditions

Cylinder: **CY1H15**
 Cushion: Standard (Adjusting bolt)
 Mounting: Horizontal wall mounting
 Speed (average): **V_a = 300 [mm/s]**
 Load mass: **W = 1 [kg]** (excluding mass of arm section)
L₁ = 50 [mm]
L₂ = 50 [mm]

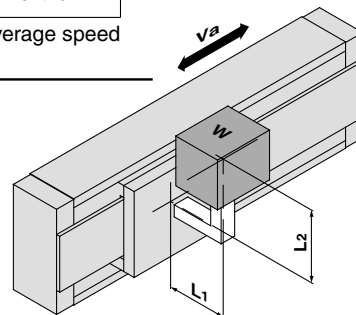

Item	Load factor α_n	Note
1 Maximum load mass 	$\alpha_1 = W/W_{\max}$ $= 1/9$ $= 0.111$	Examine W . Find the value of W_{max} when V_a = 300 mm/s from Graph (1).
2 Static moment 	$M_2 = W \cdot L_1$ $= 10 \cdot 0.05$ $= 0.5 \text{ [N}\cdot\text{m]}$ $\alpha_2 = M_2/M_2 \text{ max}$ $= 0.5/16$ $= 0.031$	Examine M₂ . Since M₁ & M₃ are not generated, investigation is unnecessary. Find the value M₂ max when V_a = 300 mm/s from Graph (3).
3 Dynamic moment 	From V = 1.4 V_a $We = \delta \cdot W \cdot V$ $= 4/100 \cdot 10 \cdot 1.4 \cdot 300$ $= 168 \text{ [N]}$ $Me_3 = 1/3 \cdot We \cdot (L_2 - A)$ $= 1/3 \cdot 168 \cdot 0.032$ $= 1.8 \text{ [N}\cdot\text{m]}$ $\alpha_3 = Me_3/Me_3 \text{ max}$ $= 1.8/7.2$ $= 0.250$	Examine Me₃ . Find the load equivalent to impact We . Damper coefficient $\delta = 4/100$ (urethane damper) Find the value of Me₃ max when V = 1.4 and V_a = 420 mm/s from Graph (2).
	$Me_1 = 1/3 \cdot We \cdot L_1$ $= 1/3 \cdot 168 \cdot 0.05$ $= 2.8 \text{ [N}\cdot\text{m]}$ $\alpha_4 = Me_1/Me_1 \text{ max}$ $= 2.8/7.2$ $= 0.389$	Examine Me₁ . From above, We = 168 Find the value of Me₃ max when V = 1.4 and V_a = 420 mm/s from Graph (2).

$$\begin{aligned} \Sigma\alpha_n &= \alpha_1 + \alpha_2 + \alpha_3 + \alpha_4 \\ &= 0.111 + 0.031 + 0.250 + 0.389 \\ &= 0.781 \end{aligned}$$

Can be used based on $\Sigma\alpha_n = 0.781 \leq 1$

Series CY1H Model Selection 4

Caution on Design (2)

Table Deflection

Table Displacement due to Pitch Moment Load

Displacement of Section A when force acts on Section F

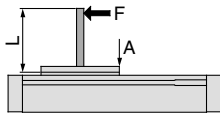

$$M1 = F \times L$$

CY1H10

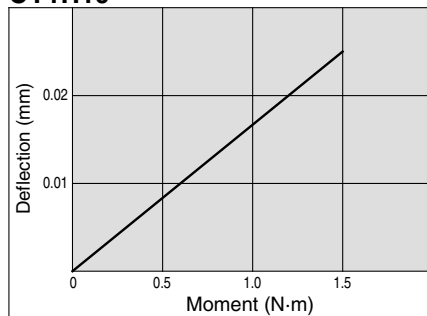

CY1H15/20/25

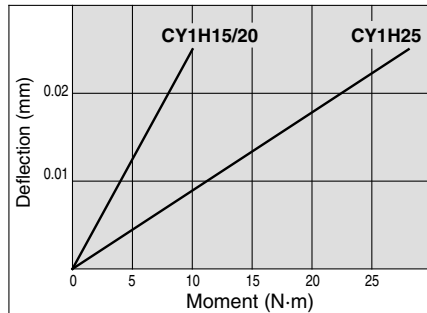

CY1HT25/32

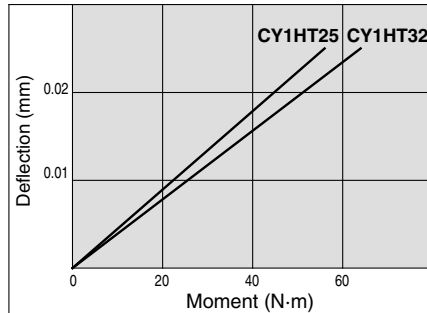
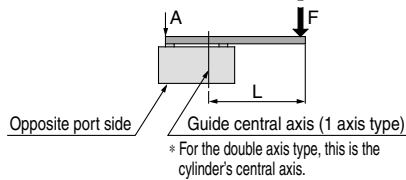

Table Displacement due to Roll Moment Load

Displacement of Section A when force acts on Section F



$$M2 = F \times L$$

CY1H10

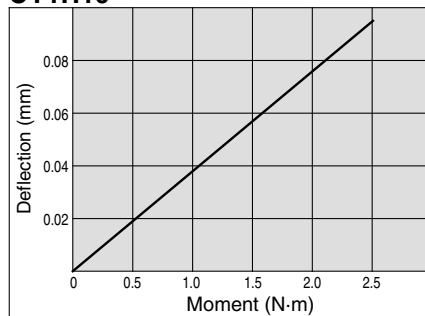

CY1H15/20/25

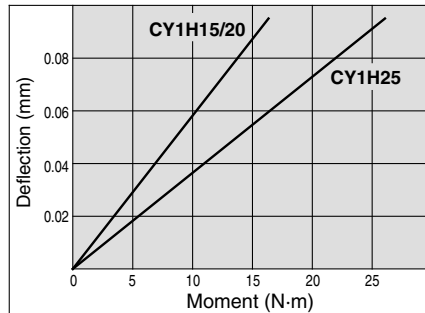

CY1HT25/32

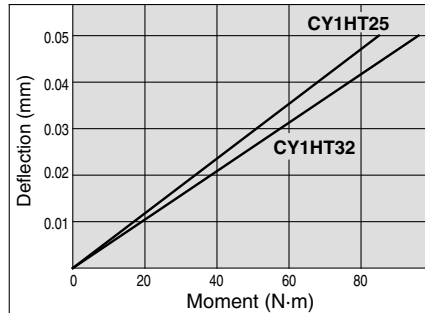
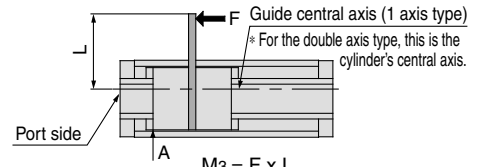

Table Displacement due to Yaw Moment Load

Displacement of Section A when force acts on Section F



$$M3 = F \times L$$

CY1H10

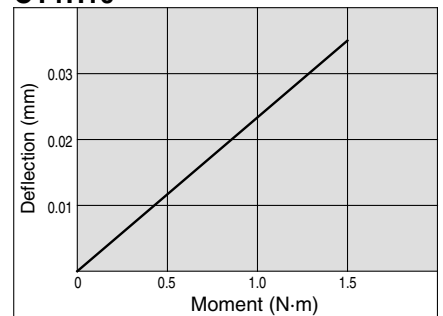

CY1H15/20/25

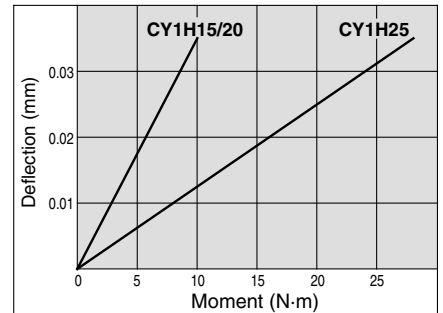

CY1HT25/32

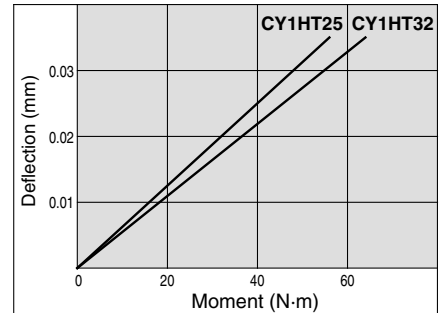

Vertical Operation

When using in vertical operation, prevention of workpiece dropping due to breaking of the magnetic coupling should be considered. The allowable load mass and maximum operating pressure should be as shown in the table below. When the cylinder is mounted vertically or sidelong, sliders may move downwards due to the self-weight or workpiece mass. If an accurate stopping position is required at the stroke end or the middle-stroke, use an external stopper to secure accurate positioning.

Model	Allowable load mass (Wv) (kg)	Maximum operating pressure Pv (MPa)
CY1H10	2.7	0.55
CY1H15	7.0	0.65
CY1H20	11.0	0.65
CY1H25	18.5	0.65
CY1HT25	18.5	0.65
CY1HT32	30.0	0.65

Intermediate Stop

(1) Intermediate Stopping of Load with External Stopper, etc.
When stopping a load in mid-stroke using an external stopper, etc., operate within the operating pressure limits shown in the table below. The magnetic coupling will break if operated at a pressure exceeding these limits.

Model	Operating pressure limit for intermediate stop Ps (MPa)
CY1H10	0.55
CY1H15	0.65
CY1H20	0.65
CY1H25	0.65
CY1HT25	0.65
CY1HT32	0.65

(2) Intermediate Stopping of Load with Air Pressure Circuit
When stopping a load using an air pressure circuit, operate at or below the kinetic energy shown in the table below. The magnetic coupling will break if the allowable value is exceeded.

Model	Allowable kinetic energy for intermediate stop Es (J)
CY1H10	0.03
CY1H15	0.13
CY1H20	0.24
CY1H25	0.45
CY1HT25	0.45
CY1HT32	0.88

CY3B
CY3R

CY1S

CY1L

CY1H

CY1F

CYP

D-□

-X□

Individual

-X□

Technical data

Magnetically Coupled Rodless Cylinder Linear Guide Type

Series CY1H

Single axis: $\phi 10$, $\phi 15$, $\phi 20$, $\phi 25$ /Double axes: $\phi 25$, $\phi 32$

How to Order

CY1H **25** - **300** - **Y7BW** -

Linear guide type

Guide

Bore size (mm)		10	15	20	25	32
Symbol		●	●	●	●	—
Nil	1 axis	●	●	●	●	—
T	2 axes	—	—	—	●	●

Bore size

10	10 mm
15	15 mm
20	20 mm
25	25 mm
32	32 mm

Port thread type

Symbol	Type	Bore size
Nil	M thread	$\phi 10$, $\phi 15$
	Rc	
TN	NPT	$\phi 20$, $\phi 25$, $\phi 32$
TF	G	

Standard stroke (mm)
Refer to "Standard Stroke" on page 1219.

Made to Order
Refer to page 1219 for details.

Number of auto switches

Nil	2 pcs.
S	1 pc.
n	"n" pcs.

Auto switch

Nil	Without auto switch (Built-in magnet)
-----	---------------------------------------

* For the applicable auto switch model, refer to the table below.

Adjustment type

Nil	With adjusting bolt
B	With shock absorbers (2 pcs.)
BS	With shock absorber (1 pc. on port side)

* The adjusting bolt is installed even when B or BS is selected. (Except $\phi 10$)

Applicable Auto Switch/Refer to pages 1263 to 1371 for further information on auto switches.

Type	Special function	Electrical entry	Indicator/light	Wiring (Output)	Load voltage		Auto switch model		Lead wire length (m)*			Pre-wired connector	Applicable load				
					DC	AC	Electrical entry direction		0.5 (Nil)	3 (L)	5 (Z)		IC circuit	Relay, PLC			
							Perpendicular	In-line									
Solid state switch	—	Grommet	Yes	3-wire (NPN)	24 V	5 V, 12 V	—	Y69A	Y59A	●	●	○	—	IC circuit	Relay, PLC		
				3-wire (PNP)				Y7PV	Y7P	●	●	○					
				2-wire				Y69B	Y59B	●	●	○					
				3-wire (NPN)				Y7NWV	Y7NW	●	●	○					
				3-wire (PNP)				Y7PWV	Y7PW	●	●	○					
				2-wire				Y7BWV	Y7BW	●	●	○					
Reed switch	—	Grommet	Yes	3-wire (NPN equivalent)	24 V	5 V	—	—	Z76	●	●	—	—	IC circuit	—		
				2-wire				5 V, 12 V	100 V	—	Z73	●				●	●
										100 V or less	—	Z80				●	●

* Lead wire length symbols: 0.5 m..... Nil (Example) Y7BW
3 m..... L (Example) Y7BWL
5 m..... Z (Example) Y7BWZ

* Solid state auto switches marked with "○" are produced upon receipt of order.

• For details about auto switches with pre-wired connector, refer to pages 1328 and 1329.

• Normally closed (NC = b contact) solid state auto switches (D-Y7G/Y7H types) are also available. Refer to page 1292 for details.

* Auto switches are shipped together, (but not assembled).

Magnetically Coupled Rodless Cylinder Linear Guide Type **Series CY1H**

Specifications



Made to Order Specifications
(For details, refer to pages 1401, 1405 and 1549.)

Symbol	Specifications
—XB10	Intermediate stroke (Using exclusive body)
—XB11	Long stroke
—X168	Helical insert thread specifications

Bore size (mm)	10	15	20	25	32
Fluid	Air				
Action	Double acting				
Maximum operating pressure	0.7 MPa				
Minimum operating pressure	0.2 MPa				
Proof pressure	1.05 MPa				
Ambient and fluid temperature	-10 to 60°C				
Piston speed	70 to 1000 mm/s				
Cushion (External stopper)	Urethane bumpers on both ends (Standard), Shock absorber (Option)				
Lubrication	Not required (Non-lube)				
Stroke length tolerance	0 to 1.8 mm				
Holding force N	53.9	137	231	363	588
Piping	Centralized piping type				
Piping port size	M5 x 0.8		Rc 1/8		

Theoretical Output

(N)

Bore size (mm)	Piston area (mm ²)	Operating pressure (MPa)					
		0.2	0.3	0.4	0.5	0.6	0.7
10	78	15	23	31	39	46	54
15	176	35	52	70	88	105	123
20	314	62	94	125	157	188	219
25	490	98	147	196	245	294	343
32	804	161	241	322	402	483	563

Note) Theoretical output (N) = Pressure (MPa) x Piston area (mm²)

Amount of Adjustment by Adjusting Bolt

Stroke adjustment on one side of 15 mm (CY1H10/15/20) or 30 mm (CY1H25, CY1HT25, CY1HT32) can be performed with the adjustment bolt, but when the amount of adjustment exceeds 3 mm, the magnetic coupling may be broken depending on the operating conditions. Therefore, operation should conform to the intermediate stop conditions on page 1217.

Do not adjust strokes by moving the stopper, as this can cause cylinder damage.

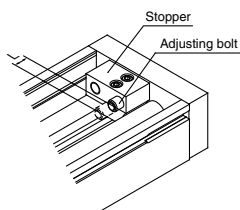

Model	Stroke adjustment range L (mm)
CY1H10, CY1H15, CY1H20	0 to 15
CY1H25, CY1HT25, CY1HT32	0 to 30

Standard Stroke

Bore size (mm)	Number of axes	Standard stroke (mm) ^{Note)}	Maximum available stroke (mm)
10	1 axis	100, 200, 300	500
15		100, 200, 300, 400, 500	750
20		100, 200, 300, 400, 500, 600	1000
25		100, 200, 300, 400, 500, 600, 800	1200
25	2 axes	100, 200, 300, 400, 500, 600, 800, 1000	
32			

Note) Strokes are manufacturable in 1 mm increments up to the maximum strokes. Suffix “-XB10” to the end of the part number for intermediate strokes excluding standard strokes and “XB11” for strokes exceeding standard strokes up to the manufacturable maximum strokes.

Mass

(kg)

Model	Standard stroke (mm)							
	100	200	300	400	500	600	800	1000
CY1H10	1.0	1.3	1.6	—	—	—	—	—
CY1H15	2.2	2.7	3.2	3.6	4.1	—	—	—
CY1H20	3.0	3.5	4.0	4.4	4.9	5.4	—	—
CY1H25	4.6	5.3	6.0	6.6	7.3	8.0	9.4	—
CY1HT25	5.1	6.2	7.3	8.3	9.4	10.4	12.5	14.6
CY1HT32	8.4	9.6	10.7	11.9	13.0	14.2	16.5	18.8

Shock Absorber Specifications

Refer to the Series RB in Best Pneumatics No. 3 for the details on shock absorbers.

Applicable cylinder size (mm)	10	15	20	25	32	
Shock absorber model	RB0805	RB0806	RB1006	RB1411	RB2015	
Maximum energy absorption (J)	0.98	2.94	3.92	14.7	58.8	
Stroke absorption (mm)	5	6	6	11	15	
Collision speed (m/s) *	0.05 to 5					
Max. operating frequency (cycle/min)	80		70	45	25	
Spring force (N)	Extended		1.96	4.22	6.86	8.34
	Retracted		3.83	22	6.18	15.30
Mass (g)	15		25	65	150	

* It denotes the values at the maximum energy absorption per one cycle. Therefore, the operating frequency can be increased according to the energy absorption.

The shock absorber service life is different from that of the CY1H cylinder. Refer to the Specific Product Precautions for the replacement period.

CY3B
CY3R

CY1S

CY1L

CY1H

CY1F

CYP

D-□

-X□

Individual

-X□

Technical data

Series CY1H

Construction

Single axis type / CY1H

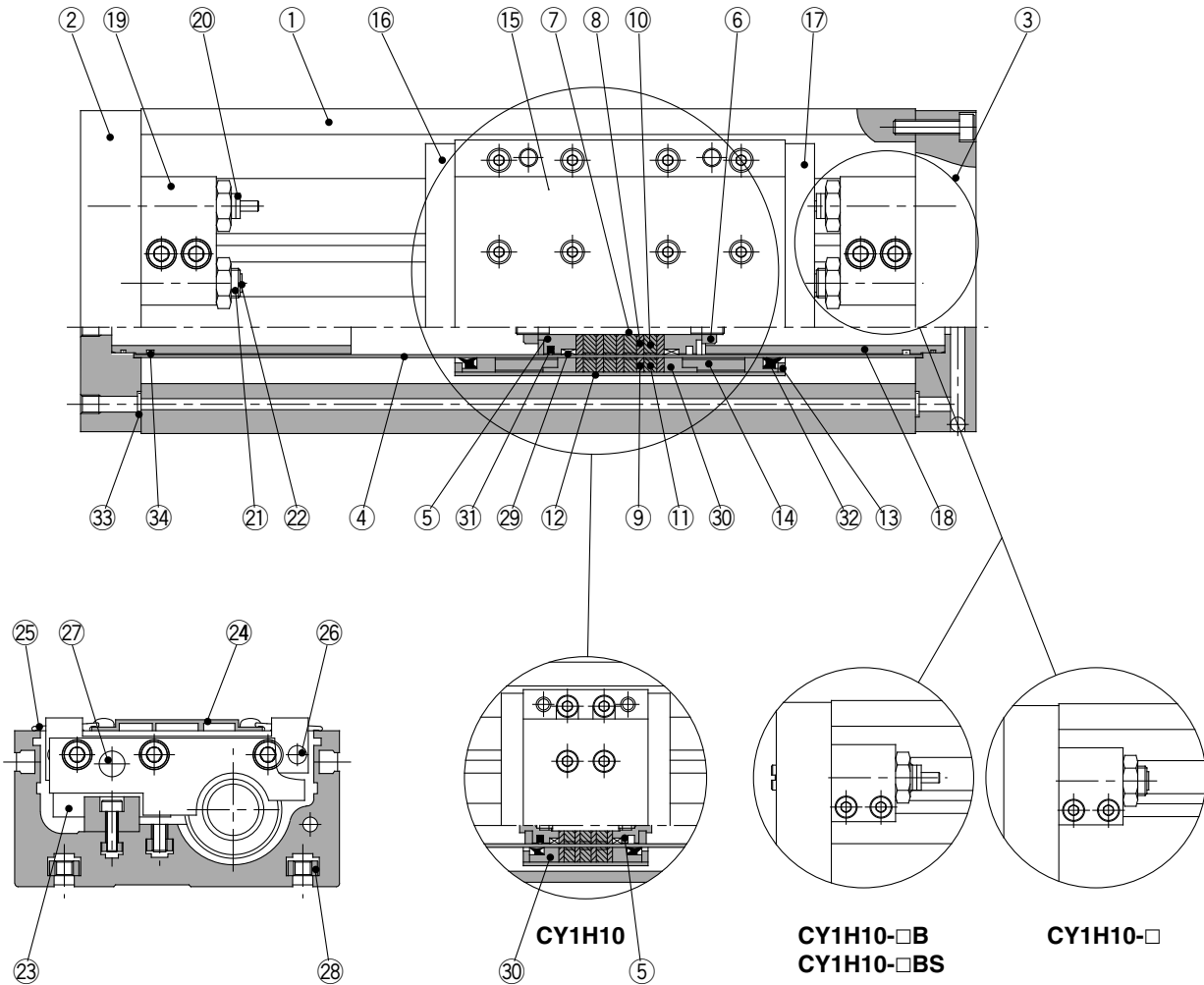

Component Parts

No.	Description	Material	Note
1	Body	Aluminum alloy	Anodized
2	Plate A	Aluminum alloy	Anodized
3	Plate B	Aluminum alloy	Anodized
4	Cylinder tube	Stainless steel	
5	Piston	Brass	Electroless nickel plated (CY1H10/15)
		Aluminum alloy	Chromated (CY1H20/25)
6	Piston nut	Carbon steel	Zinc chromated (Except CY1H10/15)
7	Shaft	Stainless steel	
8	Piston side yoke	Rolled steel plate	Zinc chromated
9	External slider side yoke	Rolled steel plate	Zinc chromated
10	Magnet A	—	
11	Magnet B	—	
12	External slider tube	Aluminum alloy	
13	Spacer	Rolled steel plate	Nickel plated
14	Space ring	Aluminum alloy	Chromated (Except CY1H10)
15	Slide table	Aluminum alloy	Anodized
16	Side plate A	Aluminum alloy	Anodized
17	Side plate B	Aluminum alloy	Anodized
18	Internal stopper	Aluminum alloy	Anodized
19	Stopper	Aluminum alloy	Anodized
20	Shock absorber	—	Series RB
21	Adjusting bolt	Chrome molybdenum steel	Nickel plated
22	Adjusting bumper	Urethane rubber	
23	Linear guide	—	
24	Top cover	Aluminum alloy	Anodized
25	Dust cover	Special resin	

No.	Description	Material	Note
26	Magnet (For auto switch)	—	
27	Parallel pin	Carbon steel	Nickel plated
28	Square nut for body mounting	Carbon steel	Nickel plated
29*	Wear ring A	Special resin	
30*	Wear ring B	Special resin	
31*	Piston seal	NBR	
32*	Scraper	NBR	
33*	O-ring	NBR	
34*	O-ring	NBR	

Note) 4 square nuts for body mounting are included regardless of strokes.

Replacement Parts: Seal Kit

Bore size (mm)	Kit no.	Contents
10	CY1H10-PS	Set of the above nos. 29, 30, 31, 32, 33, 34
15	CY1H15-PS	
20	CY1H20-PS	
25	CY1H25-PS	

* Seal kit includes 29 to 34. Order the seal kit, based on each bore size.

* Seal kit includes a grease pack (ø10: 5 and 10 g, ø15 to ø25: 10 g).

Order with the following part number when only the grease pack is needed.

Grease pack part no. for ø10: GR-F-005 (5 g) for external sliding parts,

GR-S-010 (10 g) for tube interior

Grease pack part no. for ø15 to ø25: GR-S-010 (10 g)

Construction

Double axes type / CY1HT

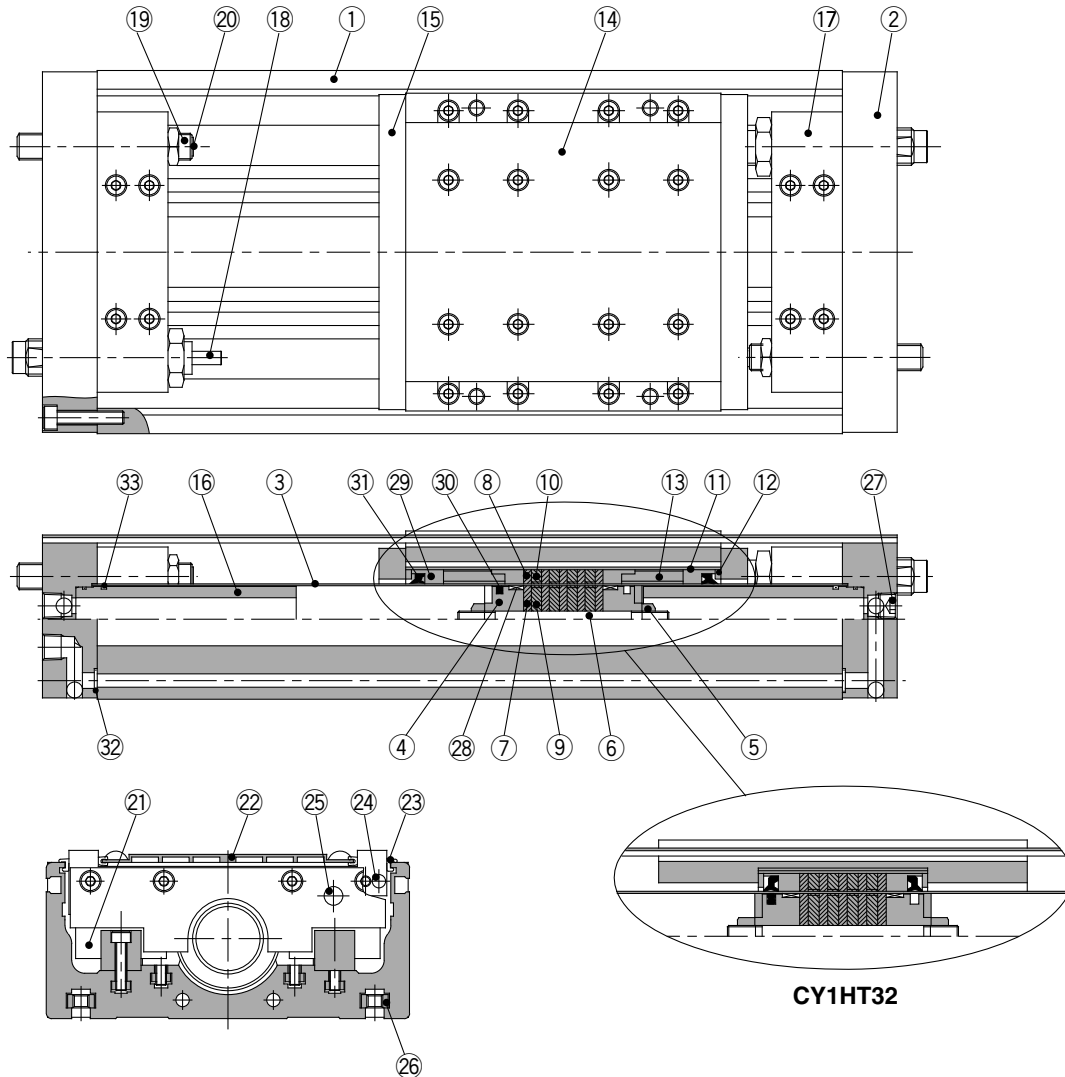

Component Parts

No.	Description	Material	Material
1	Body	Aluminum alloy	Anodized
2	Plate	Aluminum alloy	Anodized
3	Cylinder tube	Stainless steel	
4	Piston	Aluminum alloy	Chromated
5	Piston nut	Carbon steel	Zinc chromated
6	Shaft	Stainless steel	
7	Piston side yoke	Rolled steel plate	Zinc chromated
8	External slider side yoke	Rolled steel plate	Zinc chromated
9	Magnet A	—	
10	Magnet B	—	
11	External slider tube	Aluminum alloy	
12	Spacer	Rolled steel plate	Nickel plated
13	Space ring	Aluminum alloy	Chromated (Except CY1HT32)
14	Slide table	Aluminum alloy	Anodized
15	Side plate	Aluminum alloy	Anodized (Except CY1HT32)
16	Internal stopper	Aluminum alloy	Anodized
17	Stopper	Aluminum alloy	Anodized
18	Shock absorber	—	Series RB
19	Adjusting bolt	Chrome molybdenum steel	Nickel plated
20	Adjusting bumper	Urethane rubber	
21	Linear guide	—	
22	Top cover	Aluminum alloy	Anodized
23	Dust cover	Special resin	
24	Magnet (For auto switch)	—	
25	Parallel pin	Stainless steel	

No.	Description	Material	Material
26	Square nut for body mounting	Carbon steel	Nickel plated
27	Hexagon socket head taper plug	Carbon steel	Nickel plated
28*	Wear ring A	Special resin	
29*	Wear ring B	Special resin	
30*	Piston seal	NBR	
31*	Scraper	NBR	
32*	O-ring	NBR	
33*	O-ring	NBR	

Note) 4 square nuts for body mounting are included regardless of strokes.

Replacement Parts: Seal Kit

Bore size (mm)	Kit no.	Contents
25	CY1HT25-PS	Set of the above nos.
32	CY1HT32-PS	28, 29, 30, 31, 32, 33

* Seal kit includes 28 to 33. Order the seal kit, based on each bore size.

* Seal kit includes a grease pack (10 g).

Order with the following part number when only the grease pack is needed.

Grease pack part no.: GR-S-010 (10 g)

CY3B
CY3R
CY1S
CY1L
CY1H
CY1F
CYP

D-□

-X□

Individual

-X□

Technical data

Series CY1H

Dimensions

Single axis type / $\varnothing 10$

CY1H10

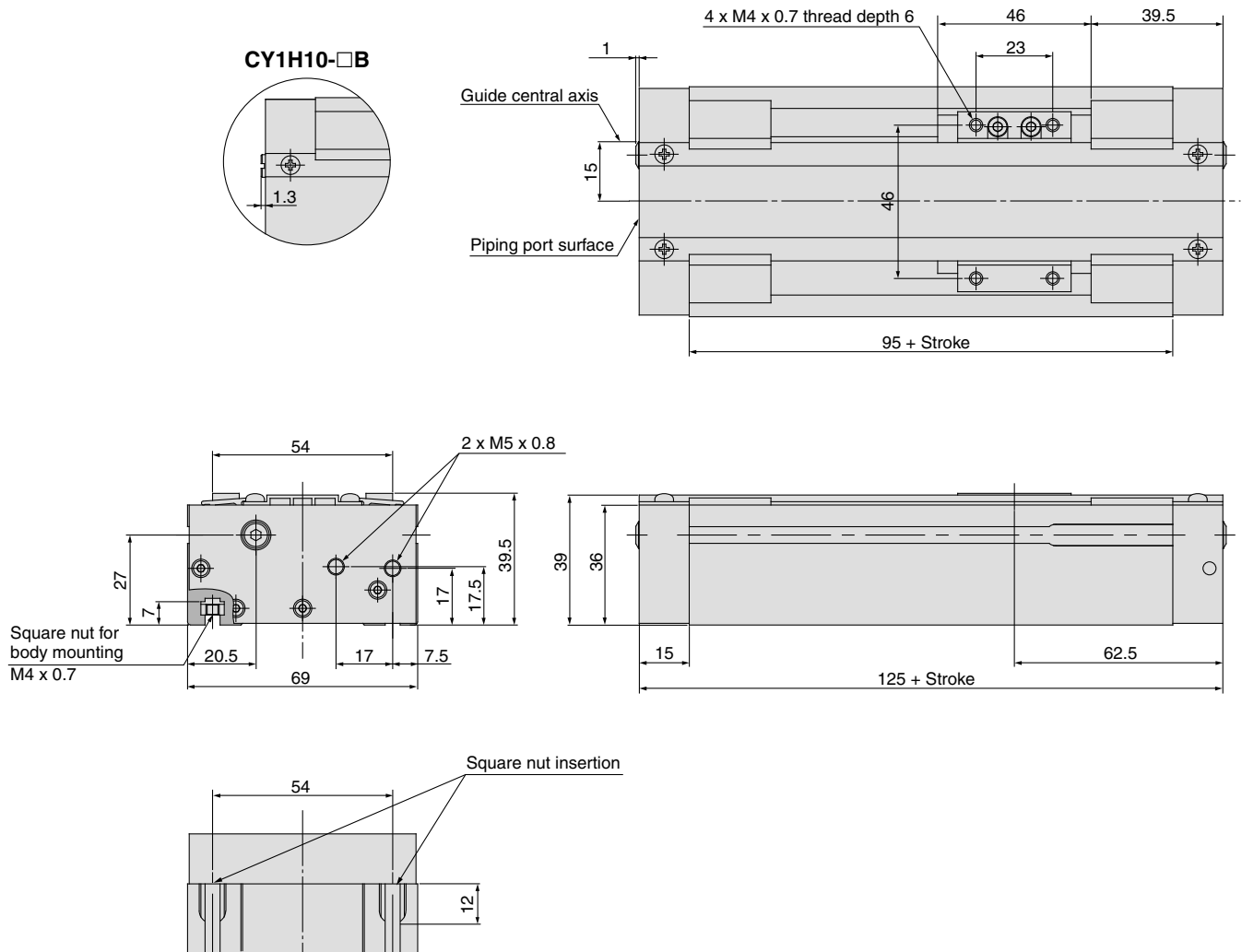

Dimensions

**Single axis type / $\varnothing 15, \varnothing 20, \varnothing 25$
CY1H15/20/25**

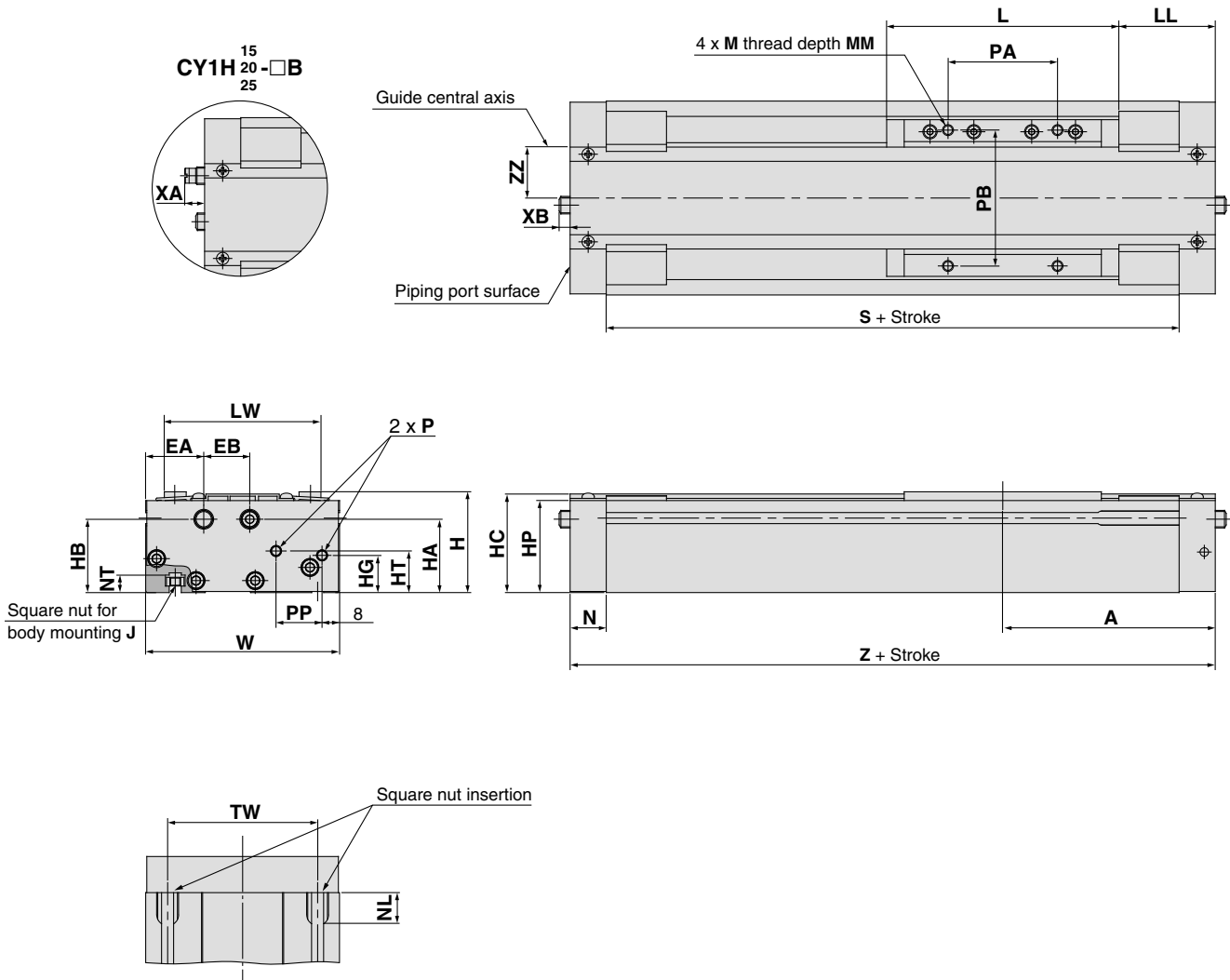

- CY3B
- CY3R
- CY1S
- CY1L
- CY1H
- CY1F
- CYP

(mm)

Model	A	EA	EB	H	HA	HB	HC	HG	HP	HT	J	L	LL	LW	M	MM	N	NL	NT
CY1H15	97	26.5	21	46	33.5	33.5	45	17	42	19	M5 x 0.8	106	44	71.5	M5 x 0.8	8	16.5	15	8
CY1H20	102.5	26.5	22	54	42.5	41.5	53	16	50	23.5	M5 x 0.8	108	48.5	75.5	M5 x 0.8	8	18	15	8
CY1H25	125	29	24	63	46	46	61.5	25	58.5	28	M6 x 1.0	138	56	86	M6 x 1.0	10	20.5	18	9

Model	P	PA	PB	PP	S	TW	W	XA	XB	Z	ZZ
CY1H15	M5 x 0.8	50	62	21	161	65	88.5	—	—	194	17.5
CY1H20	Rc1/8	50	65	23	169	70	92.5	—	—	205	19.5
CY1H25	Rc1/8	65	75	27	209	75	103	11.3	9.5	250	23.5

- D-□
- X□
- Individual
 -X□
- Technical
data

Series CY1H

Dimensions

Double axes type: / $\varnothing 25$, $\varnothing 32$

CY1HT25/32

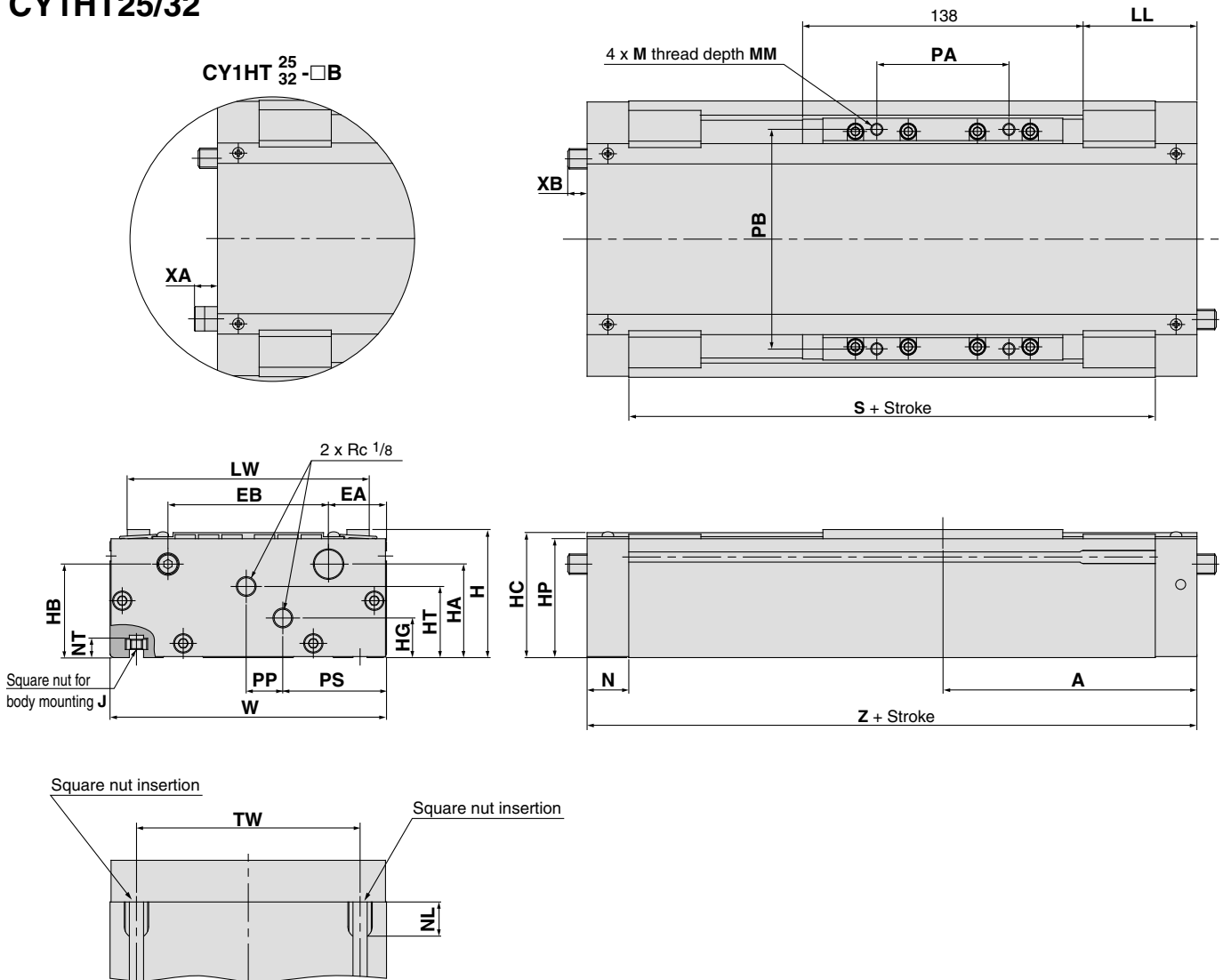

Model	A	EA	EB	H	HA	HB	HC	HG	HP	HT	J	LL	LW	M	MM	N	NL	NT	PA
CY1HT25	125	28.5	79	63	46	46	61.5	19.5	58.5	35	M6 x 1.0	56	119	M6 x 1.0	10	20.5	18	9	65
CY1HT32	132.5	30	90	75	52.5	57.5	72.5	25	69.5	43	M8 x 1.25	63.5	130	M8 x 1.25	12	23	22.5	12	66

Model	PB	PP	PS	S	TW	W	XA	XB	Z
CY1HT25	108	18	51	209	110	136	11.3	9.5	250
CY1HT32	115	14	61	219	124	150	9.7	2	265

Proper Auto Switch Mounting Position (Detection at stroke end)

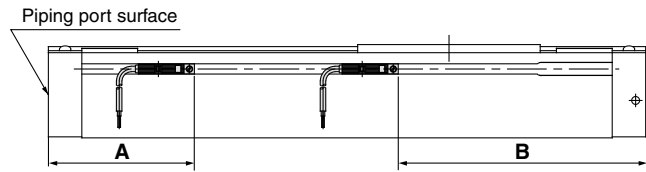

Cylinder model	Applicable auto switch	
	D-Z7□/ Z80/ Y5□/ Y6□/ Y7□	
	A	B
CY1H10	65.5	59.5
CY1H15	72	122
CY1H20	77.5	127.5
CY1H25	86	164
CY1HT25	86	164
CY1HT32	82	183

* 50 mm is the minimum stroke available with 2 auto switches mounted. Please contact SMC in the case of a stroke less than this.

Note) Adjust the auto switch after confirming the operating conditions in the actual setting.

Mounting of Auto Switch

To install the auto switch, insert the auto switch into the installation groove of the cylinder from the direction shown in the drawing on the right, and tighten the auto switch mounting screws attached to the auto switch with a watchmaker's screwdriver after setting the mounting position.

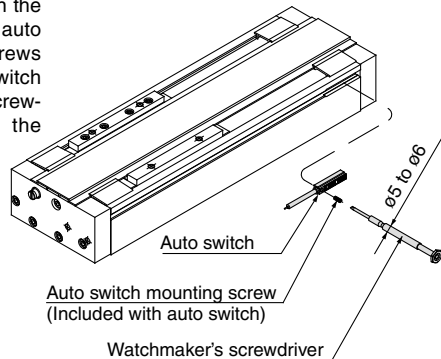

Note) Use a watchmaker's screwdriver with a grip diameter of 5 to 6 mm to tighten the auto switch mounting screws (attached to the auto switch). The tightening torque should be 0.05 to 0.1 N•m.

Auto Switch Lead Wire Containment Groove

On models CY1H20 and CY1H25 a groove is provided on the side of the body (one side only) to contain auto switch lead wires. This should be used for management of wiring.

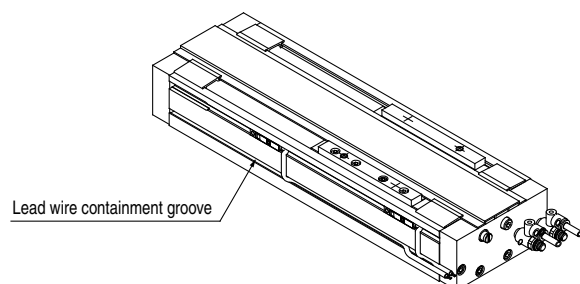

Operating Range

Cylinder model	Auto switch model	Bore size (mm)				
		10	15	20	25	32
CY1H	D-Z7□/ Z80	8	6	6	6	—
	D-Y5□/ Y6□/ Y7□	6	5	5	5	—
CY1HT	D-Z7□/ Z80	—	—	—	6	9
	D-Y5□/ Y6□/ Y7□	—	—	—	5	6

* Some auto switches cannot be mounted.

* Since this is a guideline including hysteresis, not meant to be guaranteed. (Assuming approximately $\pm 30\%$ dispersion)
There may be the case it will vary substantially depending on an ambient environment.

CY3B
CY3R

CY1S

CY1L

CY1H

CY1F

CYP

D-□

-X□

Individual
-X□

Technical
data



Series CY1H Specific Product Precautions 1

Be sure to read before handling. Refer to front matters 54 and 55 for Safety Instructions and pages 3 to 11 for Actuator and Auto Switch Precautions.

Mounting

⚠ Caution

1. The interior is protected to a certain extent by the top cover, however, when performing maintenance, etc., take care not to cause scratches or other damage to the cylinder tube, slide table or linear guide by striking them or placing objects on them. Cylinder bores are manufactured to precise tolerances, so that even a slight deformation may cause faulty operation.
2. Because the slider is supported by precision bearings, take care not to apply strong impacts or excessive moments to the table when loading a workpiece.
3. Mounting of the cylinder body

The body is mounted using the square nuts, which are included, in the two T-slots on the bottom of the body. Refer to the table below for mounting bolt dimensions and tightening torque.

Model		CY1H10	CY1H15	CY1H20	CY1H25	CY1HT25	CY1HT32
Bolt dimensions	Thread size	M4 x 0.7	M5 x 0.8		M6 x 1.0		M8 x 1.25
	Dimension t	ℓ-7	ℓ-8	ℓ-8	ℓ-9		ℓ-12
Tightening torque	N · m	1.37	2.65		4.4		13.2

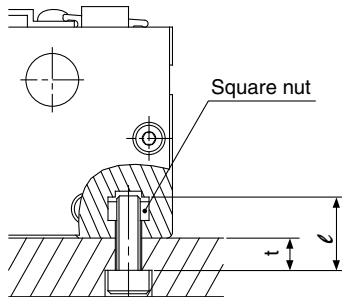

Operation

⚠ Warning

1. Be aware of the space between the plates and the slide block.
Take sufficient care to avoid getting your hands or fingers caught when the cylinder is operated.
2. Do not apply a load to a cylinder which is greater than the allowable value stated in the “Model Selection” pages.
This may cause malfunctions.
3. When the cylinder is used in a place where water or cutting oil may splash or the lubrication condition on the cylinder sliding parts would be deteriorated, please consult with SMC.
4. When applying grease to the cylinder, use the grease that has already been applied to the product. Contact SMC for available grease packs.

⚠ Caution

1. The unit can be used with a direct load within the allowable range, but when connecting to a load which has an external guide mechanism, careful alignment is necessary.
Since variation of the shaft center increases as the stroke becomes longer, a connection method should be devised which allows for this displacement.
2. Since the guide is adjusted at the time of shipment, unintentional movement of the adjustment setting should be avoided.
3. This unit can be operated without lubrication. If lubrication is performed, use turbine oil Class 1 (with no additives), ISO VG32. (Machine oil and spindle oil cannot be used.)
4. Please contact SMC before operating in an environment where there will be contact with cutting chips, dust (paper debris, lint, etc.) or cutting oil (gas oil, water, warm water, etc.).
5. Do not operate with the magnetic coupling out of position.
In case the magnetic coupling is out of position, push the external slider back into the correct position by hand at the end of the stroke (or correct the piston slider with air pressure).
6. Do not disassemble the magnetic components (piston slider, external slider).
This can cause a loss of holding power and malfunction.

Service Life and Replacement Period of Shock Absorber

⚠ Caution

1. Allowable operating cycle under the specifications set in this catalog is shown below.
 - 1.2 million times RB08□□
 - 2 million times RB10□□ to RB2725

Note) Specified service life (suitable replacement period) is the value at room temperature (20 to 25°C).
The period may vary depending on the temperature and other conditions. In some cases the absorber may need to be replaced before the allowable operating cycle above.



Series CY1H Specific Product Precautions 2

Be sure to read before handling. Refer to front matters 54 and 55 for Safety Instructions and pages 3 to 11 for Actuator and Auto Switch Precautions.

Stroke Adjustment Method

Loosen the round head Phillips Screws, and remove the top cover and dust covers (4 pcs.).

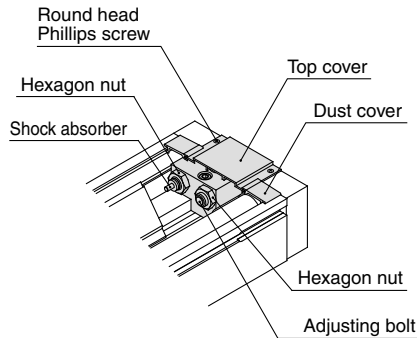

Loosen the hexagon nut, adjust the stroke with a hexagon wrench from the plate side, and secure by retightening the hexagon nut. When there is a shock absorber, loosen the hexagon nut, adjust the stroke, and then retighten the hexagon nut.

Adjustment should be performed to make effective use of the shock absorber's absorption capacity, with its position relative to the adjustment bolt as shown in the figure to the right.

⚠ Caution

1. If the effective stroke of the shock absorber is shortened by the stroke adjustment, its absorption capacity will be drastically reduced. Therefore, the adjusting bolt should be secured at a position where it projects about 0.5 mm farther than the shock absorber.

Lock Nut Tightening Torque

N·m

Model	For shock absorber	For adjusting bolt
CY1H10	1.67	1.67
CY1H15		
CY1H20	3.14	3.14
CY1H25	10.8	
CY1HT25	23.5	
CY1HT32		

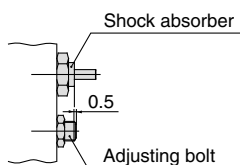

After completing the above adjustment, replace the top cover and dust covers back into place.

The round head Phillips screws for securing the top cover should be tightened with a torque of 0.58 N·m.

CY3B
CY3R

CY1S

CY1L

CY1H

CY1F

CYP

D-□

-X□

Individual
-X□

Technical
data

Low Profile Guide Type

Series *CY1F*

ø10, ø15, ø25

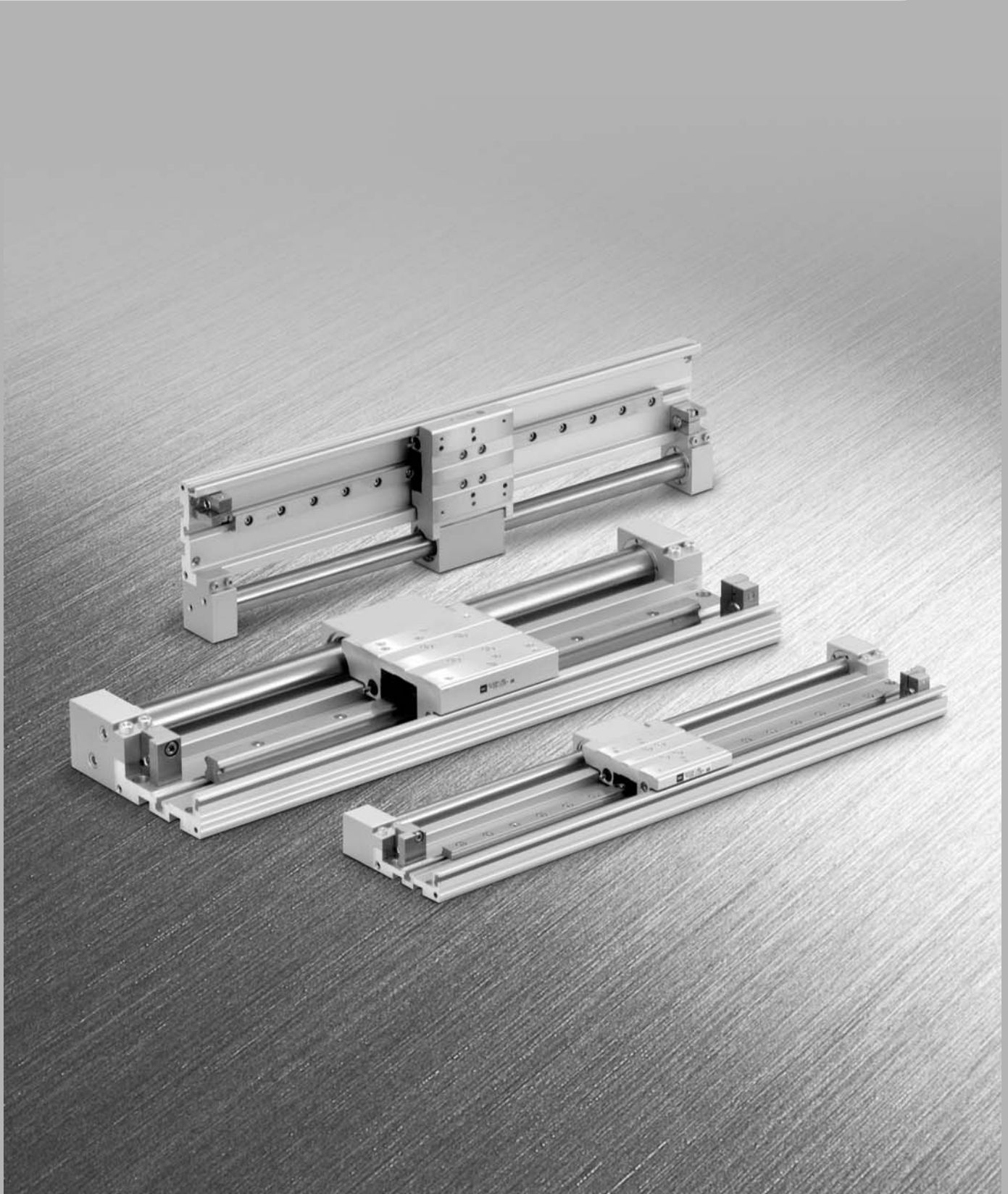

CY3B
CY3R

CY1S

CY1L

CY1H

CY1F

CYP

D-□

-X□

Individual
-X□

Technical
data

“Low profile”, “Compact body” and “Lightweight”

Low profile

Height reduced by 29%

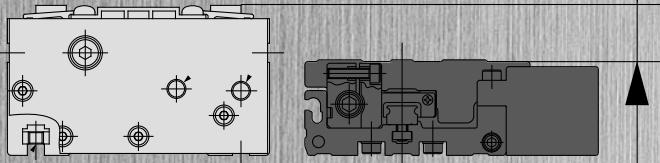

CY1H

CY1F

Height			
Series	ø10	ø15	ø25
CY1F	28	34	46
CY1H	39.5	46	63

Compact body

Overall length reduced by 31%

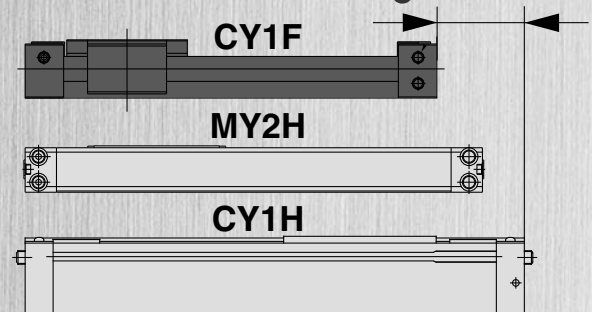

Overall length			
Series	ø10	ø15	ø25
CY1F	198	205	240
CY1H	225	294	350
MY2H	—	260	310

* For 100 mm stroke cylinder

Overall length reduced by 22% compared to Series MY2H

Magnetically coupled rodless cylinder: Low profile guide
Series CY1F: ø10, ø15, ø25

Various concentrated piping ports are available.

Piping port position can be specified using a part number.
 3 types of piping screws are available.

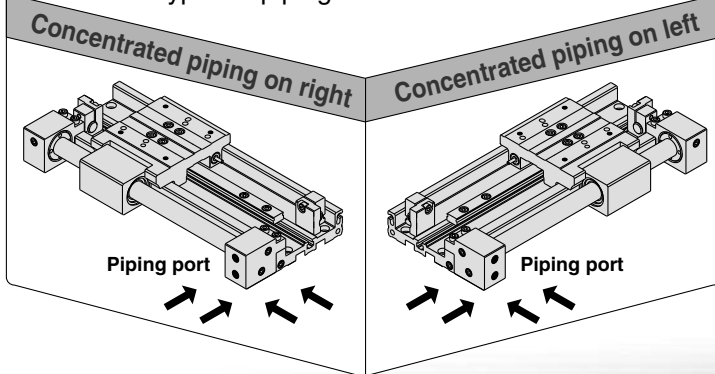

4 types of stroke adjustment are available.

Left adjustment bolt Right adjustment bolt

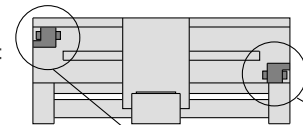

Both sides standard type	-1 mm to 0 mm	-1 mm to 0 mm
AL type	-25 mm to 0 mm	-1 mm to 0 mm
AR type	-1 mm to 0 mm	-25 mm to 0 mm
A type	-25 mm to 0 mm	-25 mm to 0 mm



Lightweight

Mass reduced by 50%

Mass			
Series	ø10	ø15	ø25
CY1F	0.7	1.1	2.5
CY1H	1.0	2.2	4.6
MY2H	—	1.3	3.2

* For 100 mm stroke cylinder

Available bore sizes ø10, 15, 25

Model	Bore size (mm)	Standard stroke (mm)											Maximum stroke	Cushion	Piping directions			
		50	100	150	200	250	300	350	400	450	500	550				600		
CY1F	10	●	●	●	●	●	●	●	●	●	●	●	●	●	●	500	Built-in shock absorber	Concentrated piping on right Concentrated piping on left
	15	●	●	●	●	●	●	●	●	●	●	●	●	●	750			
	25	●	●	●	●	●	●	●	●	●	●	●	●	●	1200			

Accumulated dust on the guide can be removed easily without an end cover.

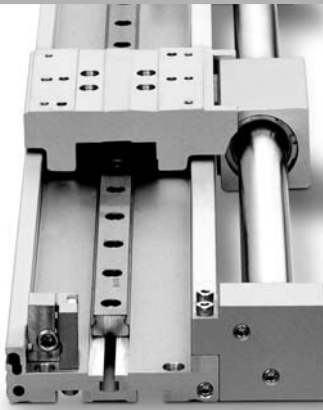

The cylinder and guide are integrated.

The cylinder portion can be replaced without interfering with the workpiece.

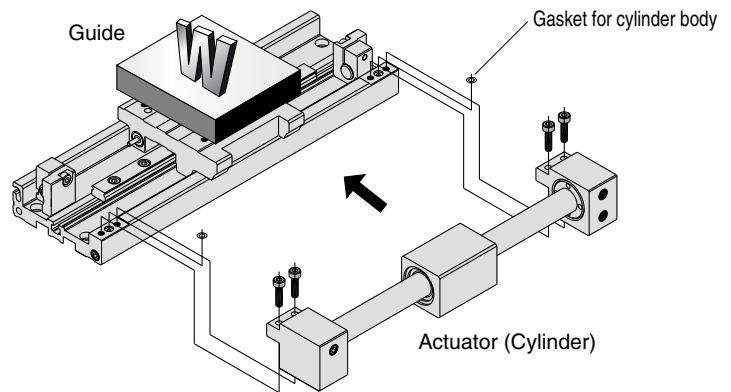

CY3B
CY3R

CY1S

CY1L

CY1H

CY1F

CYP

D-□

-X□

Individual

-X□

Technical

data

Series CY1F Model Selection 1

The following are the steps for selection of the series CY1F best suited to your application.

Standards for Tentative Model Selection

Cylinder model	Guide model	Standard for guide selection	Graph for related allowable values
CY1F	Linear guide (Single axis)	Slide table accuracy approx. ±0.05 mm or less	Refer to page 1235.

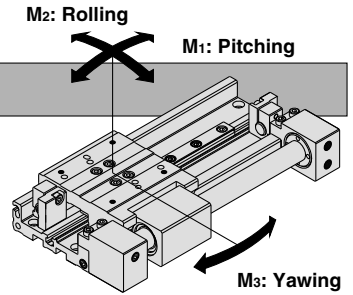

Selection Flow Chart

Es: Allowable kinetic energy for intermediate stop by pneumatic circuit (J)

Ps: Operating pressure limit for intermediate stop by external stopper, etc. Limit value (MPa)

Pv: Maximum operating pressure in vertical operation (MPa)

mv: Maximum allowable load mass in vertical operation (kg)

α : Load factor

$$\Sigma\alpha = \frac{\text{Load mass (m)}}{\text{Maximum allowable load (m}_{\max})} + \frac{\text{Static moment (M)}}{\text{Allowable static moment (M}_{\max})} + \frac{\text{Dynamic moment (ME)}}{\text{Allowable dynamic moment (ME}_{\max})}$$

E: Load kinetic energy (J)

$$E = \frac{m}{2} \left(\frac{Va}{1000} \right)^2$$

Operating Conditions

- m: Load mass (kg)
- Pv: Average speed
- P: Operating pressure (MPa)
- L: Center of gravity of the workpiece (mm)
- Mode of operation (Horizontal, Inclination, Vertical)

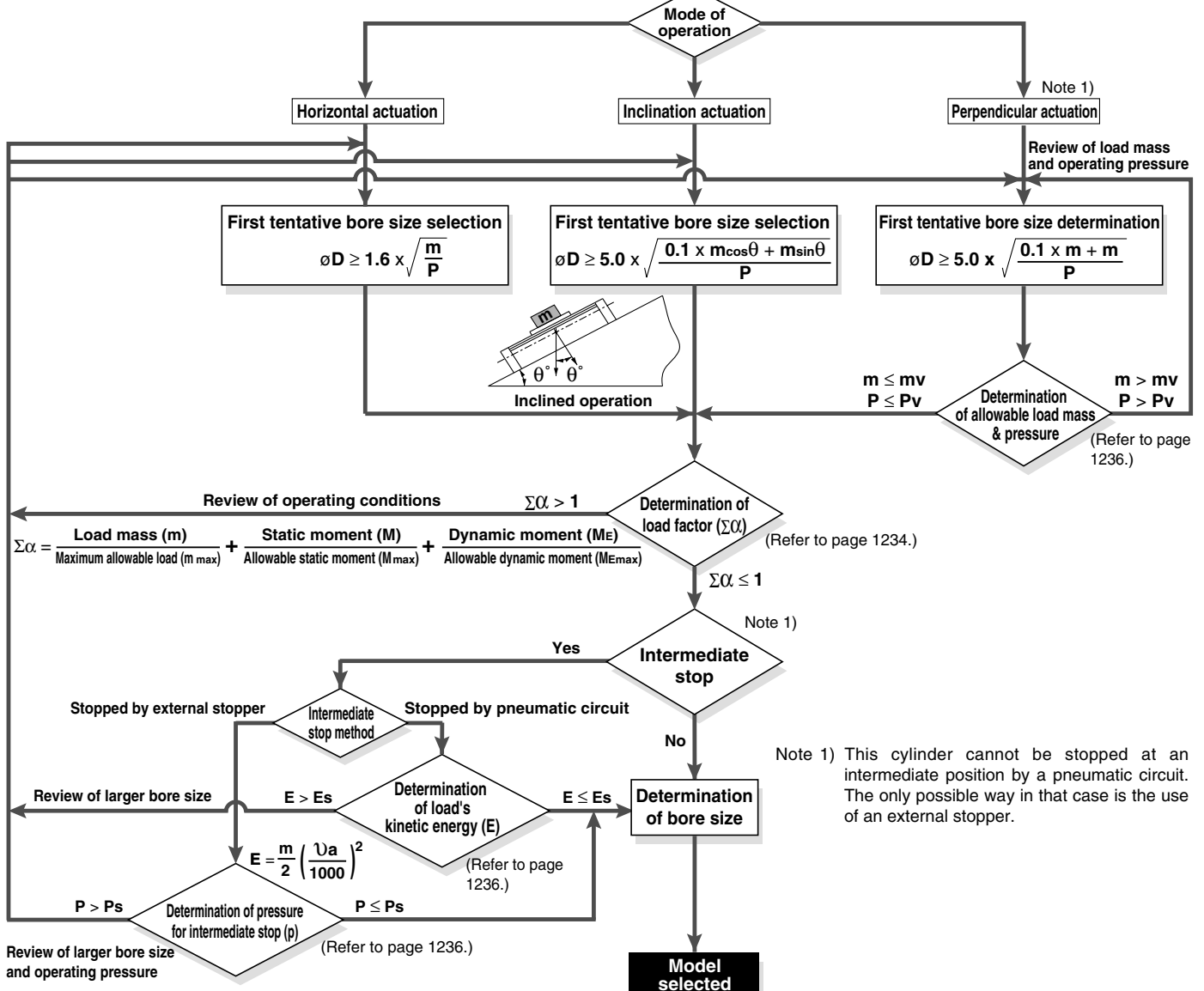

Types of Moment Applied on Rodless Cylinders

Multiple moments may be generated depending on the mounting orientation load and position of the center of gravity.

Coordinates and Moments

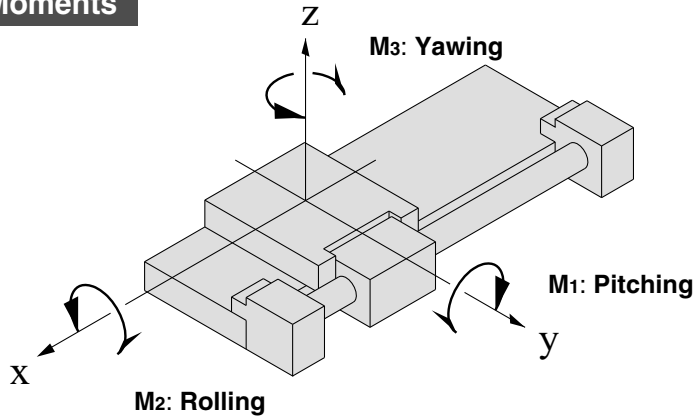

Static Moment

Horizontal mounting

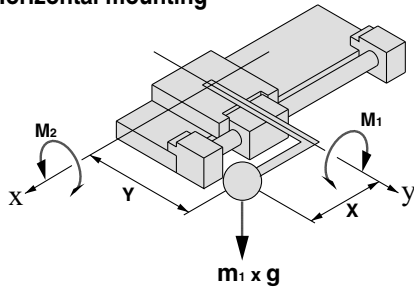

Ceiling mounting

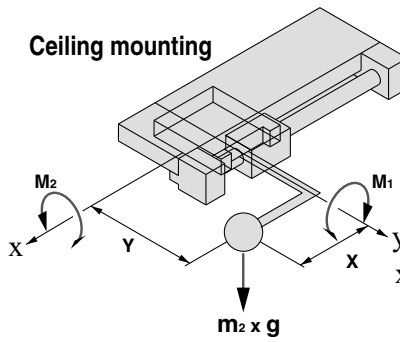

Wall mounting

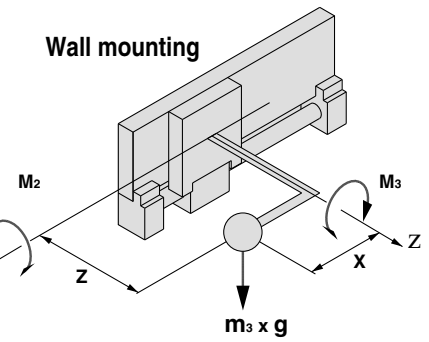

Vertical mounting

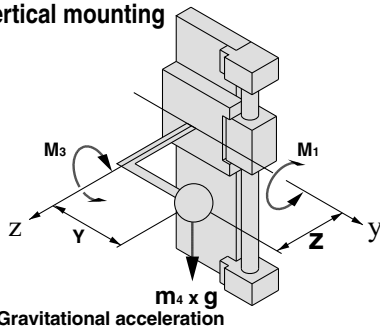

g: Gravitational acceleration

Mounting orientation	Horizontal	Ceiling	Wall	Vertical
Static load m	m₁	m₂	m₃	m₄
Static moment				
M₁	m₁ x g x X	m₂ x g x X	—	m₄ x g x Z
M₂	m₁ x g x Y	m₂ x g x Y	m₃ x g x Z	—
M₃	—	—	m₃ x g x X	m₄ x g x Y

- CY3B
- CY3R
- CY1S
- CY1L
- CY1H
- CY1F
- CYP

Dynamic Moment

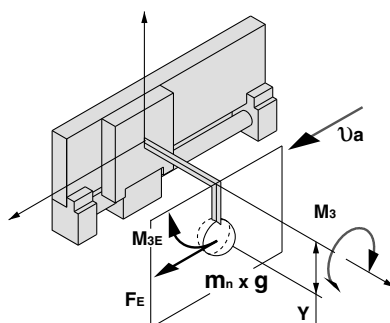
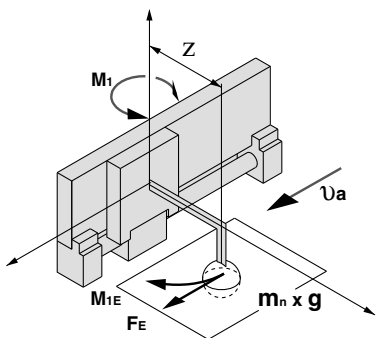

g: Gravitational acceleration, Ua: Average speed

Mounting orientation	Horizontal	Ceiling	Wall	Vertical
Dynamic load FE	$\frac{1.4}{100} \times Ua \times m_n \times g$			
Dynamic moment				
M_{1E}	$\frac{1}{3} \times FE \times Z$			
M_{2E}	Dynamic moment M_{2E} is not generated.			
M_{3E}	$\frac{1}{3} \times FE \times Y$			

Note) Regardless of the mounting orientation, dynamic moment is calculated with the formulas above.

- D-
- X
- Individual
- X
- Technical data

Series CY1F

Maximum Allowable Moment/Maximum Allowable Load

Model	Bore size (mm)	Maximum allowable moment (N-m)			Maximum allowable load (kg)			
		M ₁	M ₂	M ₃	m ₁	m ₂	m ₃	m ₄
CY1F	10	1	2	1	2	2	2	1.4
	15	1.5	3	1.5	5	5	5	2
	25	14	20	14	12	12	12	12

The above values are the maximum allowable values for moment and load. Refer to each graph regarding the maximum allowable moment and maximum allowable load for a particular piston speed.

Maximum Allowable Moment

Select the moment from within the range of operating limits shown in the graphs. Note that the maximum allowable load value may sometimes be exceeded even within the operating limits shown in the graphs. Therefore, also check the allowable load for the selected conditions.

Load (kg)

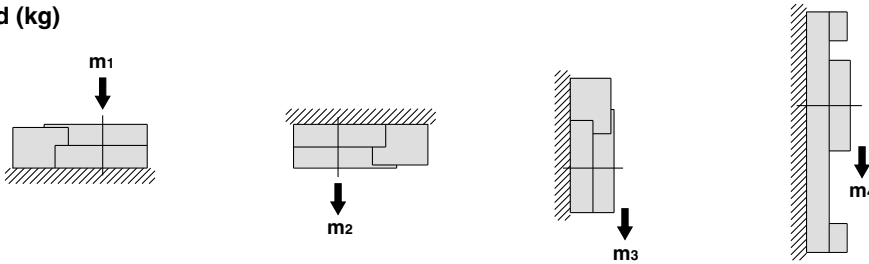

Moment (N-m)

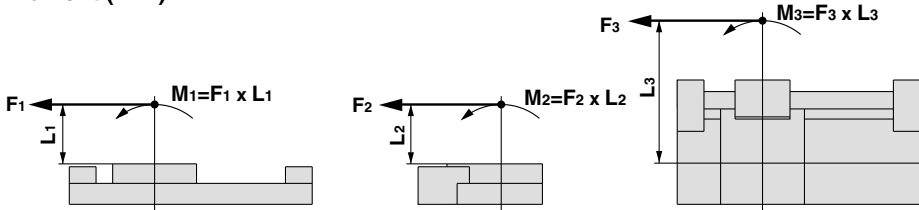

<Calculation guide load factor>

1. Maximum allowable load (1), static moment (2), and dynamic moment (3) (at the time of impact with stopper) must be examined for the selection calculations.

* To evaluate, use \bar{U}_a (average speed) for (1) and (2), and U (impact speed $U = 1.4\bar{U}_a$) for (3). Calculate m_{max} for (1) from the maximum allowable load graph (m_1, m_2, m_3, m_4) and M_{max} for (2) and (3) from the maximum allowable moment graph (M_1, M_2, M_3).

$$\text{Sum of guide load factors } \Sigma \alpha = \frac{\text{Load mass [m]}}{\text{Maximum allowable load [m}_{max}]} + \frac{\text{Static moment [M]}^{\text{Note 1}}}{\text{Allowable static moment [M}_{max}]} + \frac{\text{Dynamic moment [ME]}^{\text{Note 2}}}{\text{Allowable dynamic moment [ME}_{max}]} \leq 1$$

Note 1) Moment caused by the load, etc., with cylinder in resting condition.
 Note 2) Moment caused by the impact load equivalent at the stroke end (at the time of impact with stopper).
 Note 3) Depending on the shape of the workpiece, multiple moments may occur. When this happens, the sum of the load factors ($\Sigma \alpha$) is the total of all such moments.

2. Reference formulas [Dynamic moment at impact]

Use the following formulas to calculate dynamic moment when taking stopper impact into consideration.

- m : Load mass (kg)
- F : Load (N)
- F_E : Load equivalent to impact (at impact with stopper) (N)
- \bar{U}_a : Average speed (mm/s)
- M : Static moment (N-m)
- U : Impact speed (mm/s)
- L_1 : Distance to the load's center of gravity (m)
- ME : Dynamic moment (N-m)
- g : Gravitational acceleration (9.8 m/s²)

$$U = 1.4\bar{U}_a \text{ (mm/s)} \quad F_E = \frac{1.4}{100} \cdot \bar{U}_a \cdot g \cdot m \text{ (Note 4)}$$

$$\therefore ME = \frac{1}{3} \cdot F_E \cdot L_1 = 0.05\bar{U}_a \cdot m \cdot L_1 \text{ (N-m) (Note 5)}$$

Note 4) $\frac{1.4}{100} \cdot \bar{U}_a$ is a dimensionless coefficient for calculating impact force.

Note 5) Average load coefficient ($= \frac{1}{3}$):
 This coefficient is for averaging the maximum load moment at the time of stopper impact according to service life calculations.

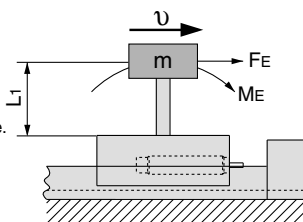

Maximum Allowable Load

Select the load from within the range of limits shown in the graphs. Note that the maximum allowable moment value may sometimes be exceeded even within the operating limits shown in the graphs. Therefore, also check the allowable moment for the selected conditions.

3. Refer to pages 1237 and 1238 for detailed selection procedures.

(1) CY1F/M₁

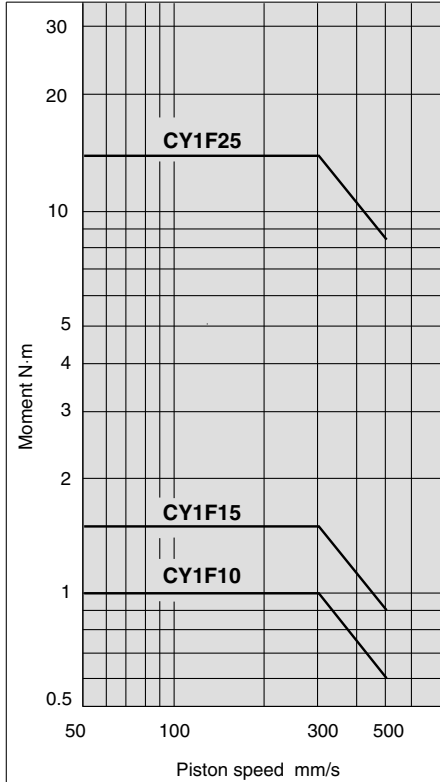

(2) CY1F/M₂

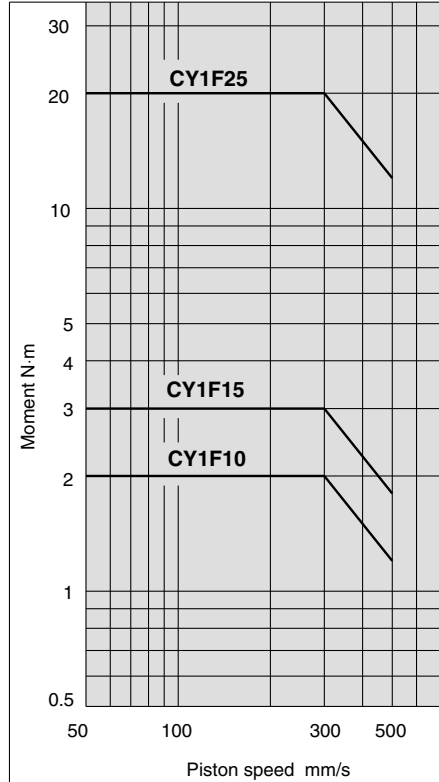

(3) CY1F/M₃

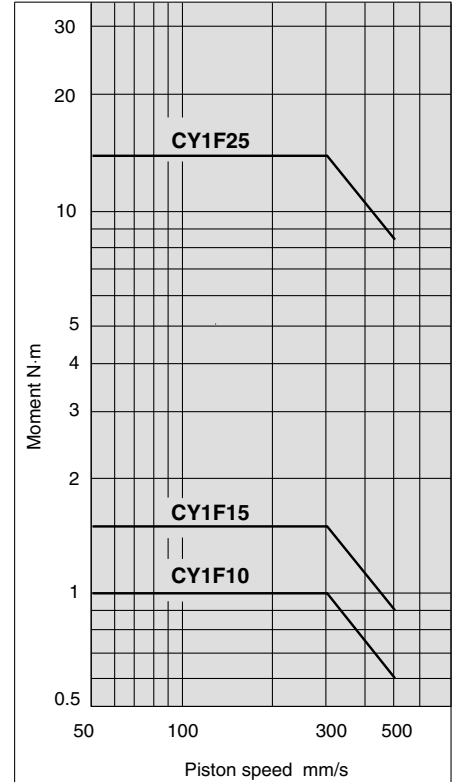

(4) CY1F/m₁

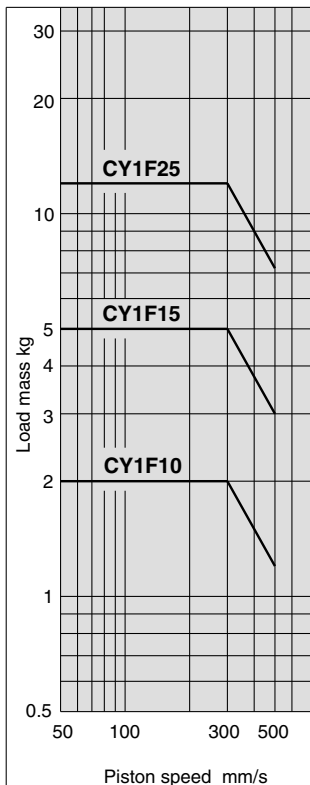

(5) CY1F/m₂

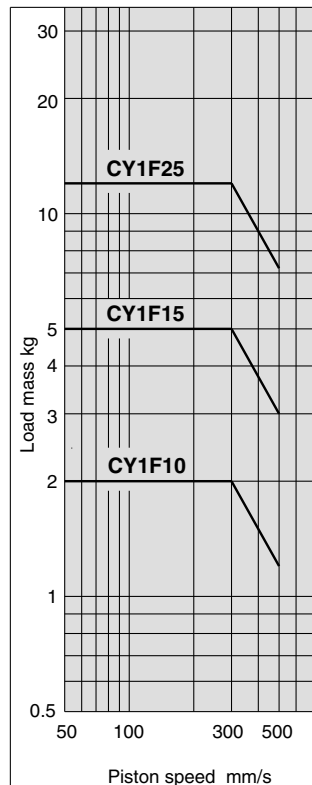

(6) CY1F/m₃

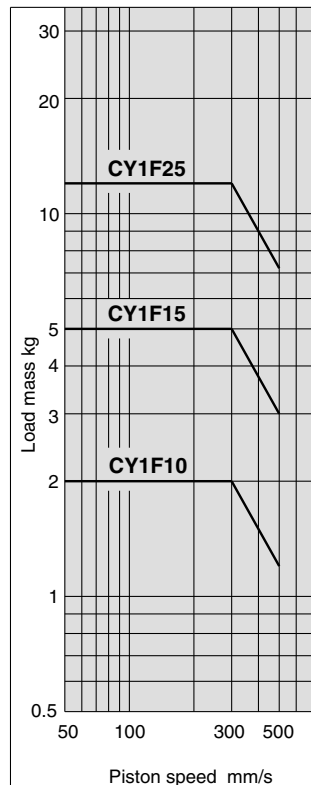

(7) CY1F/m₄

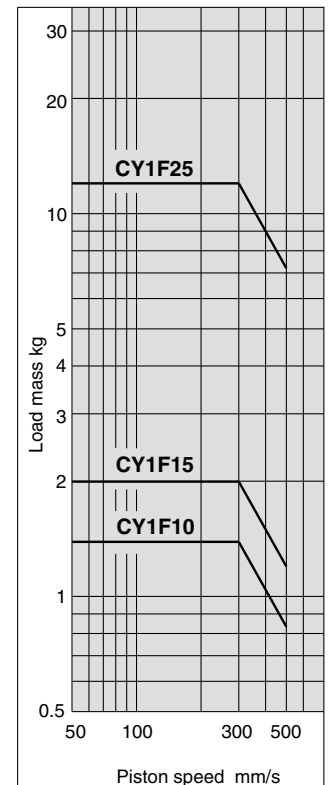

CY3B
CY3R

CY1S

CY1L

CY1H

CY1F

CYP

D-

-X

Individual
-X

Technical
data

Precautions at Vertical Operation and Intermediate Stop

Vertical Actuation

1. Vertical operation

In vertical operation, observe the maximum load mass and the maximum operating pressure shown in the table below to prevent a drop due to slipping off of magnet couplings.

Caution

If the maximum load mass or maximum operating pressure is exceeded, it will cause the magnet coupling to slip off.

Bore size (mm)	Maximum load weight mv (kg)	Maximum operating pressure Pv (MPa)
10	1.4	0.55
15	2.0	0.65
25	12	0.65

When the cylinder is mounted vertically or sideling, a slider may move downwards due to the self-weight or workpiece mass. If an accurate stopping position is required at the stroke end or the middle of stroke, use an external stopper to secure the accurate positioning.

Intermediate Stop

1. Intermediate stop by external stopper or stroke adjustment with adjustment bolt.

Observe the maximum pressure limit in the table below in case of intermediate stop by an external stopper or stroke adjustment with the attached adjustment bolt.

Caution

Be careful if the operating pressure limit is exceeded, it will cause the magnet coupling to slip off.

Bore size (mm)	Holding force (N)	Operating pressure limit for intermediate stop Ps (MPa)
10	53.9	0.55
15	137	0.65
25	363	0.65

2. The load is stopped by pneumatic circuit.

Observe the maximum kinetic energy in the table below in case the load is stopped at an intermediate position by a pneumatic circuit. Note that intermediate stop by a pneumatic circuit is not available in vertical operation.

Caution

If the allowable kinetic energy is exceeded, it will cause the magnet coupling to slip off.

Bore size (mm)	Allowable kinetic energy for intermediate stop Es (J)
10	0.03
15	0.13
25	0.45

Series CY1F

Model Selection 2

Selection Calculation

The selection calculation finds the load factors ($\Sigma\alpha_n$) of the items below, where the total (α_n) does not exceed 1.

$$\Sigma\alpha_n = \alpha_1 + \alpha_2 + \alpha_3 \leq 1$$

Item	Load factor α_n	Note
1. Maximum load mass	$\alpha_1 = m/m_{\max}$	Review m m_{\max} is the maximum load mass at v_a
2. Static moment	$\alpha_2 = M/M_{\max}$	Review M_1, M_2, M_3 M_{\max} is the allowable moment at v_a
3. Dynamic moment	$\alpha_3 = M_E/M_{E\max}$	Review M_{1E}, M_{2E}, M_{3E} $M_{E\max}$ is the allowable moment at v

v : Collision speed v_a : Average speed

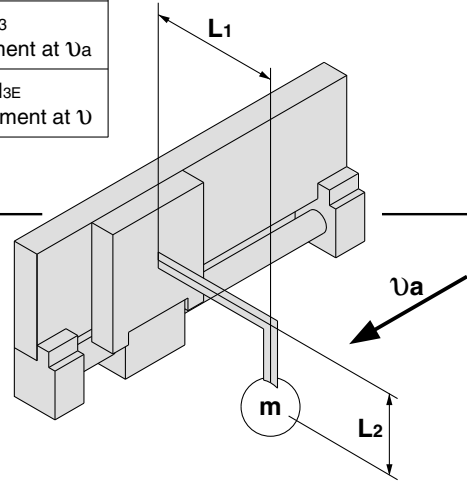

Calculation Example 1

Operating Conditions

Cylinder: CY1F15
Terminal butter mechanism: Standard (shock absorber)
Mounting: Wall mounting
Speed (average) : $v_a = 300$ [mm/s]
Load mass: $m = 0.5$ [kg] (excluding mass of arm section)
 $L_1 = 50$ [mm]
 $L_2 = 40$ [mm]

Item	Load factor α_n	Note
1. Load mass 	$\alpha_1 = m/m_{\max}$ $= 0.5/5$ $= 0.1$	Investigate m . Find the value of m_{\max} at 300 mm/s in Graph (6) for m_3 .
2. Static moment 	$M_2 = m \times g \times L_1$ $= 0.5 \times 9.8 \times 0.05$ $= 0.245$ [N·m] $\alpha_2 = M_2/M_2 \max$ $= 0.245/3$ $= 0.082$	Investigate M_2 . M_1 and M_3 are not required because they are not generated. Find the value of $M_2 \max$ at 300 mm/s in Graph (2).
3. Dynamic moment 	$M_{1E} = 1/3 \times F_E \times L_1$ $(F_E = 1.4/100 \times v_a \times g \times m)$ $= 0.05 \times v_a \times m \times L_1$ $= 0.05 \times 300 \times 0.5 \times 0.05$ $= 0.375$ [N·m] $\alpha_{3A} = M_{1E}/M_{1E \max}$ $= 0.375/1.07$ $= 0.350$	Investigate M_{1E} . Find the collision speed v . $v = 1.4 \times v_a$ $= 1.4 \times 300$ $= 420$ [mm/s] Find the value of $M_{E1 \max}$ at 420 mm/s in Graph (1).
	$M_{3E} = 1/3 \times F_E \times L_2$ $(F_E = 1.4/100 \times v_a \times g \times m)$ $= 0.05 \times v_a \times m \times L_2$ $= 0.05 \times 300 \times 0.5 \times 0.04$ $= 0.3$ [N·m] $\alpha_{3B} = M_{3E}/M_{3E \max}$ $= 0.3/1.07$ $= 0.28$	Investigate M_{3E} . From above, find the value of $M_{3E \max}$ at 420 mm/s in Graph (3).

From above,

$$\Sigma\alpha_n = \alpha_1 + \alpha_2 + \alpha_{3A} + \alpha_{3B} = 0.1 + 0.082 + 0.35 + 0.28 = 0.812$$

From $\Sigma\alpha_n = 0.812 \leq 1$, it is applicable.

CY3B
CY3R

CY1S

CY1L

CY1H

CY1F

CYP

D-

-X

Individual
-X

Technical
data

Series CY1F

Model Selection 3

Calculation Example 2

Operating Conditions

Cylinder: **CY1F25**
 Terminal buffer mechanism: Standard (shock absorber)
 Mounting: Vertical mounting
 Speed (average) : $\upsilon_a = 300$ [mm/s]
 Load mass: $m = 3$ [kg] (excluding mass of arm section)
 $L_1 = 50$ [mm]
 $L_2 = 40$ [mm]

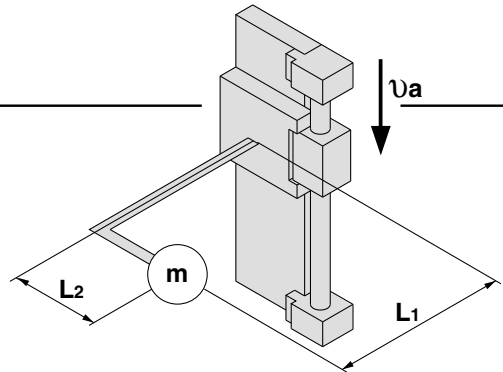

Item	Load factor α_n	Note
1. Load mass 	$\alpha_1 = m/m_{max}$ $= 3/12$ $= 0.25$	Investigate m . Find the value of m_{max} at 300 mm/s in Graph (7) for m_4 .
2. Static moment 	$M_1 = m \times g \times L_1$ $= 3 \times 9.8 \times 0.05$ $= 1.47$ [N·m] $\alpha_{2a} = M_1/M_1_{max}$ $= 1.47/14$ $= 0.105$	Investigate M_1 . Find the value of M_1_{max} at 300 mm/s in Graph (1).
	$M_3 = m \times g \times L_2$ $= 3 \times 9.8 \times 0.04$ $= 1.176$ [N·m] $\alpha_{2b} = M_3/M_3_{max}$ $= 1.176/14$ $= 0.084$	Investigate M_3 . Find the value of M_3_{max} at 300 mm/s in Graph (3).
3. Dynamic moment 	$M_{1E} = 1/3 \times F_E \times L_1$ $(F_E = 1.4/100 \times \upsilon_a \times g \times m)$ $= 0.05 \times \upsilon_a \times m \times L_1$ $= 0.05 \times 300 \times 3 \times 0.05$ $= 2.25$ [N·m] $\alpha_{3A} = M_{1E}/M_{1E_{max}}$ $= 2.25/10$ $= 0.225$	Investigate M_{1E} . Find the collision speed υ . $\upsilon = 1.4 \times \upsilon_a$ $= 1.4 \times 300$ $= 420$ [mm/s] Find the value of $M_{1E_{max}}$ at 420 mm/s in Graph (1).
	$M_{3E} = 0.05 \times \upsilon_a \times m \times L_2$ $(F_E = 1.4/100 \times \upsilon_a \times g \times m)$ $= 0.05 \times 300 \times 3 \times 0.04$ $= 1.8$ [N·m] $\alpha_{3B} = M_{3E}/M_{3E_{max}}$ $= 1.8/10$ $= 0.18$	Investigate M_{3E} . From above, find the value of $M_{3E_{max}}$ at 420 mm/s in Graph (3).

From above,

$$\Sigma \alpha_n = \alpha_1 + \alpha_{2a} + \alpha_{2b} + \alpha_{3A} + \alpha_{3B} = 0.25 + 0.105 + 0.084 + 0.225 + 0.18 = 0.844$$

From $\Sigma \alpha_n = 0.844 \leq 1$, it is applicable.

Magnetically Coupled Rodless Cylinder: Low Profile Guide Type

Series **CY1F**

ø10, ø15, ø25

How to Order

CY1F **10** **R** - **300** - **M9BW** -

• **Bore size (mm)**

10	10
15	15
25	25

• **Thread type**

Symbol	Type	Bore size (mm)
Nil	M	10, 15
	Rc	25
TN	NPT	
TF	G	

• **Made to Order**
Refer to page 1240 for details.

• **Number of auto switches**

Nil	2 pcs.
S	1 pc.
n	"n" pcs.

• **Auto switch**

Nil	Without auto switch (Built-in magnet)
-----	---------------------------------------

* For the applicable auto switch model, refer to the table below.

• **Adjustment bolt**

Nil	Both sides are standard
AL	Right: Standard For 25 mm adjustment on left
AR	For 25 mm adjustment on right Left: Standard
A	For 25 mm adjustment on both sides

• **Piping direction**

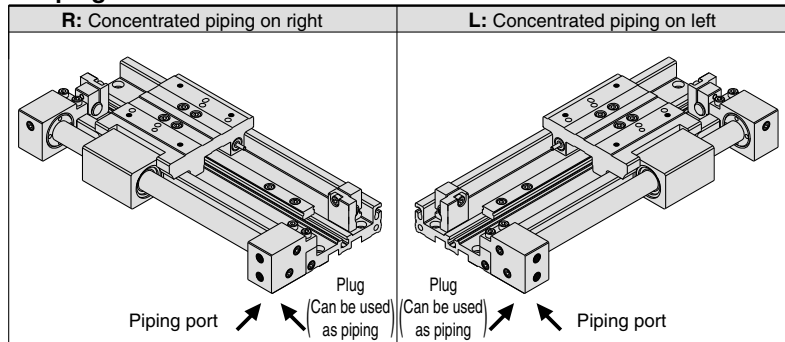

Applicable Auto Switch/Refer to pages 1263 to 1371 for further information on auto switches.

Type	Special function	Electrical entry	Indicator light	Wiring (output)	Load voltage		Auto switch model		Lead wire length (m)				Pre-wired connector	Applicable load			
					DC	AC	Perpendicular	In-line	0.5 (Nil)	1 (M)	3 (L)	5 (Z)					
Solid state switch	—	Grommet	Yes	3-wire (NPN)	24 V	5 V, 12 V	—	M9NV	M9N	●	●	●	○	○	IC circuit	Relay, PLC	
				3-wire (PNP)				M9PV	M9P	●	●	●	○				
				2-wire				M9BV	M9B	●	●	●	○				
	3-wire (NPN)			24 V	5 V, 12 V	—	M9NWV	M9NW	●	●	●	○	○	IC circuit			
	3-wire (PNP)						M9PWV	M9PW	●	●	●	○					
	2-wire						M9BWV	M9BW	●	●	●	○					
Feed switch	—	Grommet	Yes	3-wire (NPN equiv.)	—	5 V	—	A96V	A96	●	—	●	—	●	IC circuit	—	
				2-wire	24 V	12 V	100 V	A93V	A93	●	—	●	—	●	—	—	Relay, PLC
							100 V or less	A90V	A90	●	—	●	—	●	—	●	—

* Lead wire length symbols: 0.5 m Nil (Example) M9NW
1 m M (Example) M9NWM
3 m L (Example) M9NWL
5 m Z (Example) M9NWZ

* Solid state auto switches marked with a "○" symbol are produced upon receipt of order.

* For details about auto switches with pre-wired connector, refer to pages 1328 and 1329.

* Normally closed (NC = b contact) solid state auto switches (D-F9G/F9H types) are also available. Refer to page 1290 for details.

* The auto switch is shipped together, but not assembled.

CY3B
CY3R

CY1S

CY1L

CY1H

CY1F

CYP

D-□

-X□

Individual
-X□

Technical
data

Series CY1F



Made to Order Specifications
(For details, refer to pages 1401 and 1405.)

Symbol	Specifications
-XB10	Intermediate stroke (Using exclusive body)
-XB11	Long stroke

Specifications

Bore size (mm)	10	15	25
Fluid	Air		
Lubrication	Non-lube		
Action	Double acting		
Maximum operating pressure (MPa)	0.7		
Min. operating pressure (MPa)	0.2		
Proof pressure (MPa)	1.05		
Ambient and fluid temperature (°C)	-10 to 60		
Piston speed (mm/s)	50 to 500		
Cushion	Built-in shock absorber		
Stroke length tolerance (mm)	0 to 250st: $^{+1.0}_0$	251 to 1000st: $^{+1.4}_0$	1001st to: $^{+1.8}_0$
Stroke adjustment movable range (mm) ^{Note 1)}	-1.2 to 0.8		-1.4 to 0.6
Piping type	Centralized piping		
Port size ^{Note 2)}	M5 x 0.8		Rc 1/8

Note 1) The stroke adjustment movable range in the above table is that for the standard adjustment bolt. For more information, please refer to page 1247.

Note 2) With ø25, piping screws can be selected by the customer. (Refer to "How to Order".)

Shock Absorber Specifications

Applicable bore size (mm)	10, 15	25	
Shock absorber model	RB0805-X552	RB1006-X552	
Max. energy absorption (J)	0.98	3.92	
Stroke absorption (mm)	5	6	
Max. impact speed (m/s) ^{Note 1)}	0.05 to 5		
Max. operating frequency (cycle/min)	80	70	
Spring force (N)	When extended	1.96	4.22
	When retracted	3.83	6.18
Mass (g)	15	25	

Note 1) Represents the maximum absorption energy per cycle. Thus, the operation frequency can be increased with the absorption energy.

Note 2) The shock absorber service life is different from that of the CY1F cylinder depending on operating conditions. Refer to the Specific Product Precautions for the replacement period.

Standard Stroke

Bore size (mm)	Standard stroke (mm)	Maximum manufacturable stroke (mm)
10	50, 100, 150, 200, 250, 300	500
15	50, 100, 150, 200, 250, 300, 350, 400, 450, 500	750
25	100, 150, 200, 250, 300, 350, 400, 450, 500, 550, 600	1200



* The stroke is available in 1 mm increments with the maximum stroke as the upper limit. For a stroke in the standard stroke range, suffix the part number with -XB10. If the stroke does not fall within the standard stroke range, suffix the part no. with -XB11. Refer to the Made to Order Specifications on pages 1401 and 1405.

Magnetic Holding Force

Unit: N

Bore size (mm)	10	15	25
Magnetic holding force	53.9	137	363

Theoretical Output

Unit: N

Bore size (mm)	Piston area (mm ²)	Operating pressure [MPa]					
		0.2	0.3	0.4	0.5	0.6	0.7
10	78	15	23	31	39	46	54
15	176	35	52	70	88	105	123
25	490	98	147	196	245	294	343

Note) Theoretical output (N) = Pressure (MPa) x Piston area (mm²)

Option

Adjustment Bolt

Bore size (mm)	Standard adjustment bolt	25 mm adjustment bolt
10, 15	CYF-S10	CYF-L10
25	CYF-S25	CYF-L25

Mass

Unit: kg

Model	Basic mass	Additional mass per each 50 mm of stroke	Standard adjustment bolt mass	Mass of adjustment bolt for 25 mm adjustment
CY1F10	0.520	0.095	0.004	0.012
CY1F15	0.815	0.133	0.004	0.012
CY1F25	1.970	0.262	0.007	0.021

Calculation method

Example: **CY1F15-150AL**

Basic mass 0.815 kg
 Additional mass 0.133 kg/50 st
 Standard adjustment bolt mass 0.004 kg
 Mass of adjustment bolt for 25 mm adjustment 0.012 kg
 $0.815 + 0.133 \times 150 \div 50 + 0.004 + 0.012 = 1.23$ (kg)
 Cylinder stroke 150st
 Left 25 mm adjustment bolt
 Right Standard adjustment bolt

Replacement Parts

Part No. of Replacement Shock Absorber

Bore size (mm)	Shock absorber model no.
10, 15	RB0805-X552
25	RB1006-X552

Note) Order 2 units for each unit of cylinder.

Replacement Actuator (Cylinder)

CY1F B 10 [] R - Stroke

Cylinder identification symbol

Bore size (mm)

10	10
15	15
25	25

Piping direction

R	Centralized piping on right
L	Centralized piping on left

Thread type

Symbol	Thread type	Bore size (mm)
Nil	M	10, 15
	Rc	25
TN	NPT	
TF	G	

CY3B
CY3R

CY1S

CY1L

CY1H

CY1F

CYP

D-□

-X□

Individual
-X□

Technical
data

Series CY1F

Construction

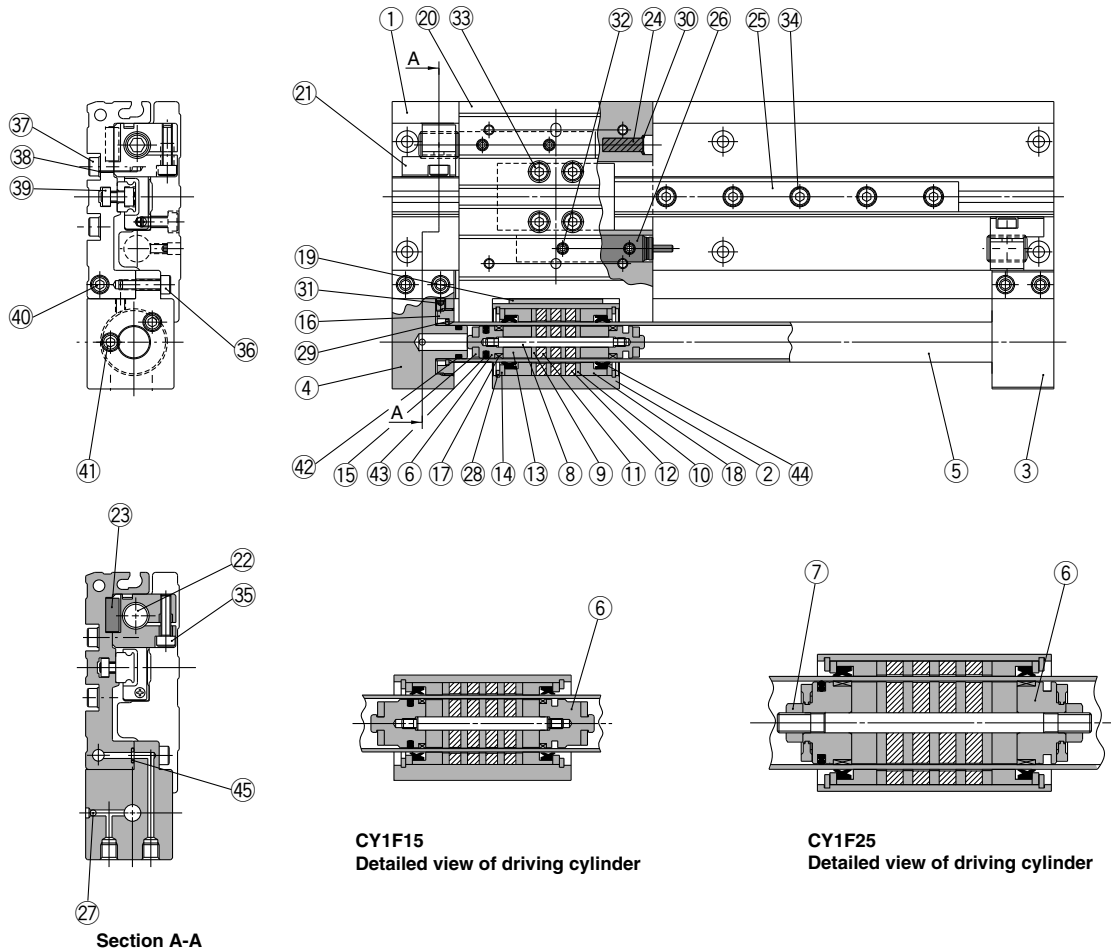

Component Parts

No.	Description	Material	Note
1	Body (rodless cylinder)	Aluminium alloy	Anodized
2	Body	Aluminium alloy	Hard anodized
3	End cover A	Aluminium alloy	Hard anodized
4	End cover B	Aluminium alloy	Hard anodized
5	Cylinder tube	Stainless steel	
6	Piston	Aluminium alloy Brass	Chromate (ø25) Electroless nickel plated (ø10, ø15)
7	Piston nut	Carbon steel	(Only for ø25)
8	Shaft	Stainless steel	
9	Piston side yoke	Rolled steel plate	Zinc chromated
10	External slider side yoke	Rolled steel plate	Zinc chromated
11	Magnet A	—	
12	Magnet B	—	
13	Piston spacer	Aluminium alloy	Chromate
14	Spacer	Rolled steel plate	Nickel plated
15	Bumper	Urethane rubber	
16	Attachment ring	Aluminium alloy	Hard anodized
17	Wear ring A	Special resin	
18	Wear ring B	Special resin	
19	Wear ring C	Special resin	
20	Slide table	Aluminium alloy	Hard anodized
21	Adjuster holder	Carbon steel	Electroless nickel plated
22	Adjustment bolt	Chrome molybdenum steel	Nickel plated
23	Adjuster holder positioning key	Carbon steel	Zinc chromated

No.	Description	Material	Note
24	Magnet	—	
25	Guide	—	
26	Shock absorber	—	
27	Steel ball	Bearing steel	
28	Type C retaining ring for hole	Carbon tool steel	Nickel plated
29	Type C retaining ring for axis	Hard steel wire Stainless steel	(ø15) (ø10, ø25)
30	Retaining ring	Stainless steel	
31	Hexagon socket head set screw	Chrome molybdenum steel	Nickel plated
32	Hexagon socket head set screw	Chrome molybdenum steel	Nickel plated
33	Hexagon socket head bolt	Chrome molybdenum steel	Nickel plated
34	Hexagon socket head bolt	Chrome molybdenum steel	Nickel plated
35	Hexagon socket head bolt	Chrome molybdenum steel	Nickel plated
36	Hexagon socket head bolt	Chrome molybdenum steel	Nickel plated
37	Hexagon socket head bolt	Chrome molybdenum steel	Nickel plated
38	Flat washer	Rolled steel	Nickel plated
39	Square nut	Carbon steel	Nickel plated
40	Hexagon socket head plug	Chrome molybdenum steel	Nickel plated
41	Hexagon socket head plug	Chrome molybdenum steel	Nickel plated (Hexagon socket head taper plug for ø25)
42	Cylinder tube gasket	NBR	
43	Piston seal	NBR	
44	Scraper	NBR	
45	Body (rodless cylinder) gasket	NBR	

Series CY1F

Proper Auto Switch Mounting Position (Detection at stroke end)

D-A9□, D-A9□V (mm)

Bore size (mm)	Mounting pattern①		Mounting pattern②		Mounting pattern③		Note 2) Operating range
	A1	B1	A2	B2	A3	B3	
10	38	60	18	80	38	80	9
15	39	66	19	86	39	86	10
25	44.5	95.5	24.5	115.5	44.5	115.5	11

D-M9□, D-M9□V, D-M9□W, D-M9□WV (mm)

Bore size (mm)	Mounting pattern①		Mounting pattern②		Mounting pattern③		Note 2) Operating range
	A1	B1	A2	B2	A3	B3	
10	34	64	22	76	34	76	5.5
15	35	70	23	82	35	82	5
25	40.5	99.5	28.5	111.5	40.5	111.5	5

Note 1) Adjust the auto switch after confirming the operating conditions in the actual setting.

Note 2) Since the operating range is provided as a guideline including hysteresis, it cannot be guaranteed (assuming approximately ±30% dispersion). It may vary substantially depending on an ambient environment.

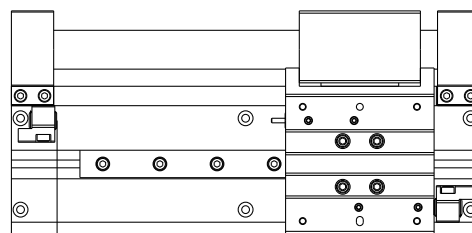

Mounting pattern ①

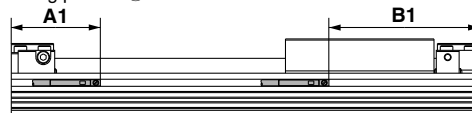

Mounting pattern ②

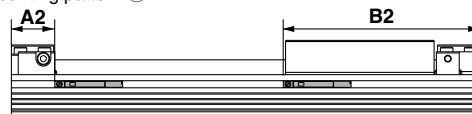

Mounting pattern ③

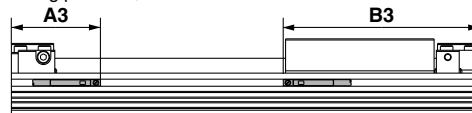

⚠ Caution

① When adjusting the stroke, confirm the minimum stroke for auto switch mounting.

See the table below for the minimum stroke for auto switch mounting.

Minimum Stroke for Auto Switch Mounting (1 pc.) (mm)

Bore size (mm)	D-A9□, D-A9□V D-M9□, D-M9□V	D-M9□W D-M9□WV
	10	5
15		
25		

Minimum Stroke for Auto Switch Mounting (2 pcs.) (mm)

Bore size (mm)	D-A90 D-A96	D-A93	D-A90V D-A96V D-A93V	D-M9□ D-M9□W	D-M9□V D-M9□WV
	Mounting pattern ①, ②	32	35	22	32
Mounting pattern ③	20			12	

Mounting of Auto Switch

As shown below, there are 3 ways to mount the auto switch according to 3 types of electrical entries. Insert the auto switch into the auto switch groove. Then use a flat head watchmaker's screwdriver to tighten the included auto switch mounting screws.

Note) When tightening the mounting screw (included with the auto switch), use a watchmaker's screwdriver with a handle 5 to 6mm in diameter.

Tightening Torque of Auto Switch Mounting Screws (N·m)

Auto switch model	Tightening torque
D-A9□(V)	0.10 to 0.20
D-M9□(V) D-M9□W(V)	0.05 to 0.15

Mounting pattern ①

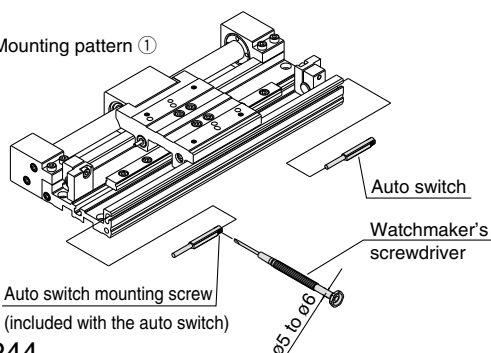

Mounting pattern ②

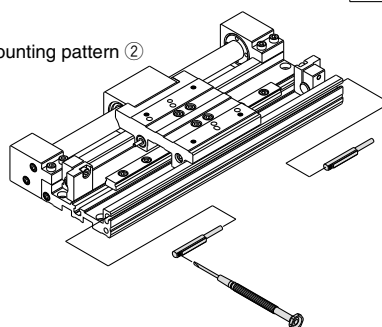

Mounting pattern ③

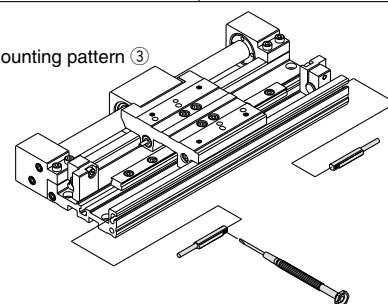



Series CY1F Specific Product Precautions 1

Be sure to read before handling.

Refer to front matters 54 and 55 for Safety Instructions and pages 3 to 11 for Actuator and Auto Switch Precautions.

Mounting

⚠ Caution

1. Do not apply a large impact or excessive moment to the slide table (slider).

Because the slide table (slider) is supported by a precision bearing, do not apply a large impact or excessive moment when mounting a workpiece.

2. Align carefully when connecting to a load with an external guide mechanism.

Although a magnetic rodless cylinder (Series CY1F) can directly receive a load within the allowable range of the guide, it is necessary to align sufficiently when connecting to a load with an external guide mechanism.

The longer the stroke is, the greater the displacement of the shaft center becomes. Therefore, adopt a connection method (floating mechanism) that can ensure absorption of the displacement.

3. Be sure to use the 4 mounting holes on both ends of the guide body when mounting the product on equipment.

The mounting hole at the center of the guide body is used to mount an intermediate support. Be sure to use the 4 mounting holes at both ends to secure the product.

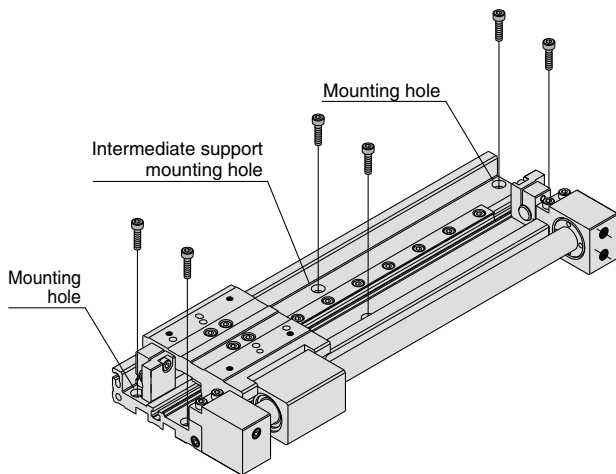

4. When a 25 mm adjustment bolt is selected, the mounting holes will be hidden behind it. Adjust the adjustment bolt after the cylinder is installed.

According to "2. Adjusting bolt adjustment" on page 1247, move the adjustment bolt to a position where it does not interfere with any of the mounting holes and secure the cylinder with mounting screws. After securing the cylinder, readjust the stroke with the adjustment bolt.

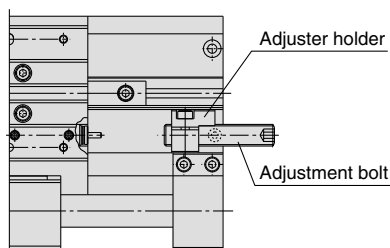

25 mm adjustment bolt

⚠ Caution

5. Long stroke operation causes deflection of the path table or cylinder tube. In such a case, provide an intermediate support.

Provide an intermediate support with the mounting holes on the center of the path table so that the distance between supports given as L in the figure will not exceed the value shown in the graph.

- If the counter surface lacks precision, malfunction may result so adjust the level at the same time.
- In an environment where vibration or impact occurs, provide an intermediate support even if the distance is within the allowable range in the graph.

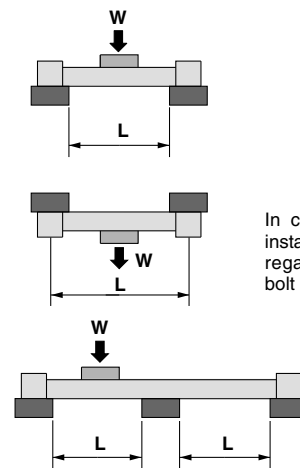

In case the product is installed on the ceiling, regard the mounting bolt pitch as L.

Distance between Load and Supports

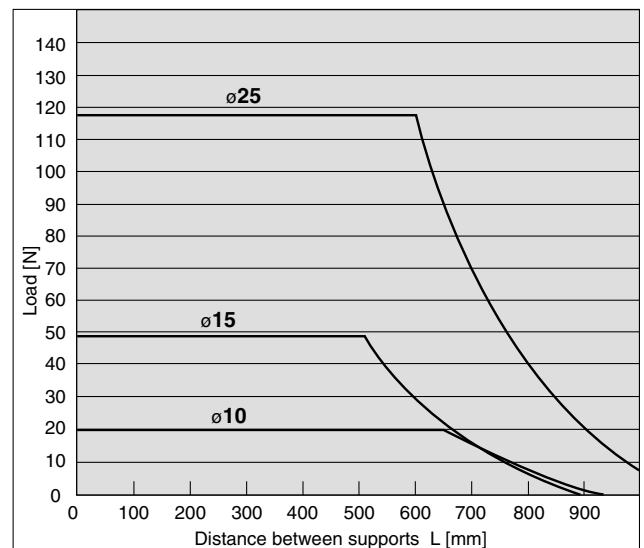

6. There are limitations on the load mass and operating pressure in case the product is used in the vertical direction.

When using the product in the vertical direction, confirm the allowable values in "Vertical Operation" in Model Selection (1) on page 1236. If the allowable value is exceeded, the magnet coupling may slip off, causing the workpiece to drop down.

CY3B
CY3R

CY1S

CY1L

CY1H

CY1F

CYP

D-

-X

Individual

-X

Technical

data



Series CY1F Specific Product Precautions 2

Be sure to read before handling.

Refer to front matters 54 and 55 for Safety Instructions and pages 3 to 11 for Actuator and Auto Switch Precautions.

Handling

⚠ Caution

1. Do not inadvertently move the guide adjusting unit.

The guide is installed at the proper tightening torque. Do not loosen the mounting bolts of the guide.

2. Do not operate the magnetic rodless cylinder if the magnet couplings on the actuator are displaced.

If the magnet couplings are displaced by an external force beyond the holding force, supply an air pressure of 0.7 MPa to the cylinder port to return the external slider to the right position of the stroke end.

3. Take precautions to avoid getting your hands caught in the unit.

Be careful not to let your hand caught between the slide table and adjuster holder at the stroke end. Install a protective cover or take some other measures to keep any part of the human body from directly touching the place.

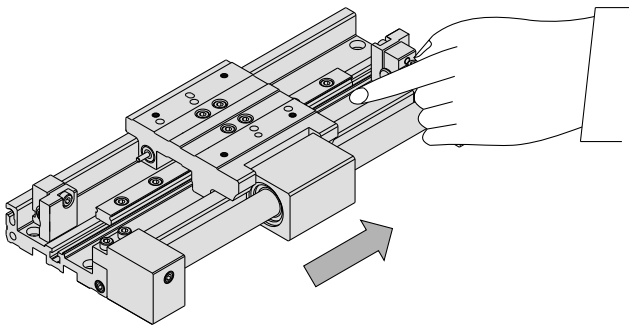

4. Never disassemble the magnetic component parts (external slider, internal slider) of the actuator (cylinder).

If will cause decline of the holding force, etc.

Piping

⚠ Caution

1. Be careful about the direction of the piping port and that of the slide table movement.

The direction of the piping port and that of the slide table movement differ between the right side centralized piping and left side centralized piping.

Centralized piping on right

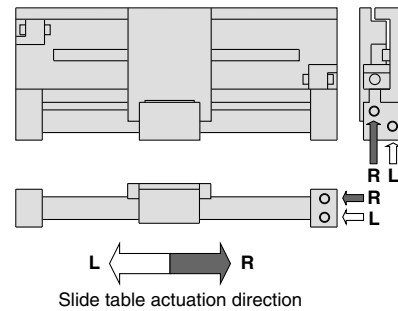

Centralized piping on left

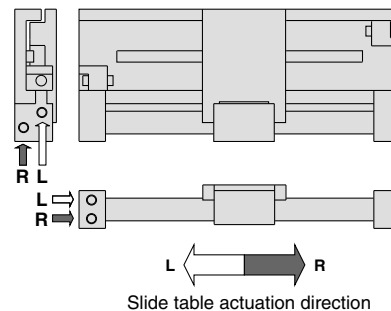

2. The plug position of the piping port can be changed to suit the operating conditions.

When screwing in the plug for the second time, wrap a sealant tape around the plug to prevent leakage.

(1) M5

First tighten lightly until the rotation stops. Then tighten an additional 1/6 to 1/4 turn.

(2) Rc 1/8

Tighten with a 7 to 9 N·m torque using tightening tools.



Series CY1F Specific Product Precautions 3

Be sure to read before handing.

Refer to front matters 54 and 55 for Safety Instructions and pages 3 to 11 for Actuator and Auto Switch Precautions.

Adjustment

⚠ Caution

1. Stroke adjustable range

The stroke of series CY1F can be controlled by adjusting the attached adjustment bolt.

For stroke adjustment amount, please refer to the table below.

Bore size (mm)	Standard adjustment bolt	25 mm adjustment bolt
10	-1.2 to 0.8	-25.2 to 0.8
15	-1.2 to 0.8	-25.2 to 0.8
25	-1.4 to 0.6	-25.4 to 0.6

(mm)

The adjustment values above are those for one side.

2. Adjusting bolt adjustment

- 1) Loose the adjustment bolt fixing bolts.
- 2) Insert a hexagon wrench into a hexagon hole at the end of the adjustment bolt to adjust the adjustment bolt.
- 3) After adjustment, tighten the adjustment bolt fixing bolts.

Bore size (mm)	Adjustment bolt fixing bolts	Tightening torque	Adjustment width across flats
10	M3	1.0 to 1.3 N·m	4
15	M3	1.0 to 1.3 N·m	4
25	M5	4.6 to 6.2 N·m	5

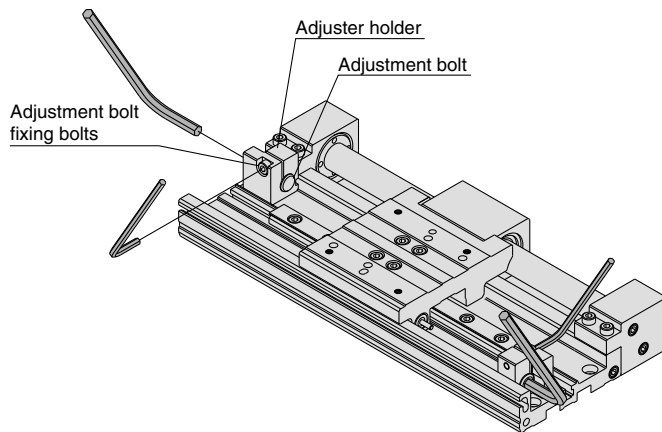

⚠ Caution

1. When adjusting the stroke, be careful about the operating pressure limits.

When making the stroke smaller than the reference stroke with the adjustment bolt, operate at a pressure below the operating pressure limit in (1) "Intermediate stop by external stopper or stroke adjustment with adjustment bolt" on page 1236. If the operating pressure limit is exceeded, the magnet coupling on the actuator (cylinder) will slip off.

2. When adjusting the stroke, use the distance from the end of the adjustment bolt to the end of the adjuster holder as a guideline.

If dimension A is made smaller than 0, the slide table and adjuster holder will collide, resulting in damage to the slide table such as scratches or gouges.

Bore size (mm)	At the minimum stroke of standard adjustment bolt	At the minimum stroke of 25 mm adjustment bolt	Basic stroke	At maximum stroke adjustment
10	$A < 2$	$A < 26$	$A = 0.8$	$A \geq 0$
15	$A < 2$	$A < 26$	$A = 0.6$	
25	$A < 2$	$A < 26$	$A = 0.6$	

(mm)

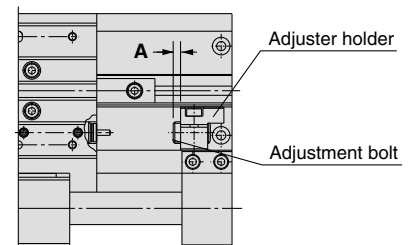

Standard adjustment bolt

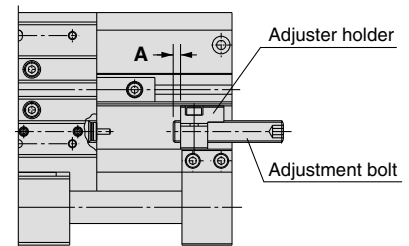

25 mm adjustment bolt

CY3B
CY3R

CY1S

CY1L

CY1H

CY1F

CYP

D-□

-X□

Individual
-X□

Technical
data



Series CY1F Specific Product Precautions 4

Be sure to read before handling.

Refer to front matters 54 and 55 for Safety Instructions and pages 3 to 11 for Actuator and Auto Switch Precautions.

Maintenance and Replacement

⚠ Caution

Replacement of Actuator

1. The actuator (cylinder) of series CY1F can be replaced.

Refer to "Replacement Actuator (Cylinder)" on page 1241 about how to order.

2. Replacement of actuator (cylinder) of series CY1F.

- 1) Remove the 4 cylinder fixing bolts and pull out the actuator from the guide.
- 2) Apply grease to the gaskets attached to the replacement actuator (cylinder) and replace the installed gaskets with the new ones.
- 3) Fit the slider of the replacement actuator into the recessed part of the slide table. Align the surface C (on the side with round mounting holes) of the end cover of the replacement actuator and surface D of the stepped part on the guide.
- 4) In the condition described in (3), put surface A and surface B in close contact with each other. Tighten the 4 cylinder fixing bolts evenly.

Bore size (mm)	Cylinder fixing bolt	Tightening torque
10	M3	0.55 to 0.72N·m
15		
25	M5	2.6 to 3.5N·m

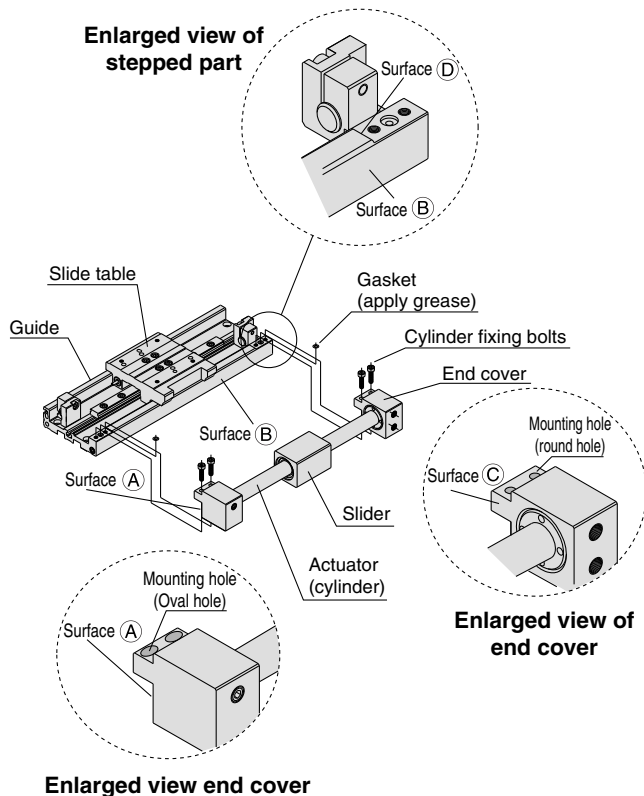

3. Be sure to fasten the cylinder fixing bolts.

Fasten the cylinder fixing bolts firmly. If they become loose, damage or malfunction may result. After replacing the actuator, be sure to conduct a test run before actually using the product.

⚠ Caution

Replacement of Shock Absorber

1. The shock absorber of series CY1F can be replaced.

The shock absorber should be replaced as a spare part if a decline in the energy absorption capacity is observed.

Refer to the table below about how to order a replacement shock absorber.

Bore size (mm)	No.
10	RB0805-X552
15	
25	RB1006-X552

2. Replacement of shock absorber

Follow the steps below to replace the shock absorber.

- 1) Remove the workpiece from the slide table.
- 2) Loosen the 4 hexagon socket head screws on the top of the slide table and pull out the shock absorber.
- 3) Insert the replacement shock absorber into the slide table until it reaches the rear end and tighten 4 hexagon socket head screws.

Bore size (mm)	Hexagon socket head set screw	Tightening torque
10	M3	0.37 to 0.45 N·m
15		
25	M5	0.54 to 0.64 N·m

3. Be careful about the tightening torque of the hexagon socket head screws.

Be careful excessive tightening may cause damage or malfunction of the shock absorber.

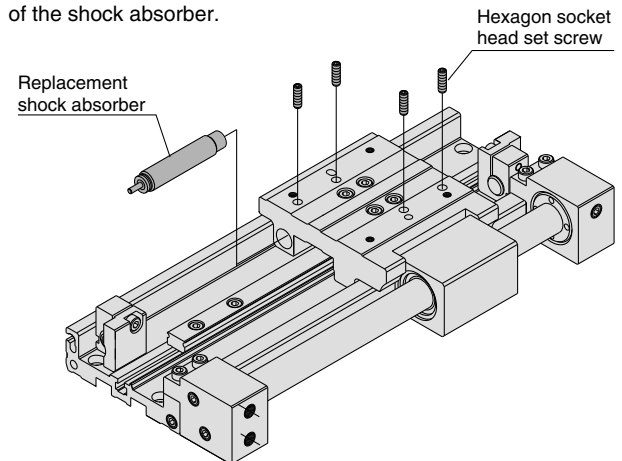

Service Life and Replacement Period of Shock Absorber

⚠ Caution

1. Allowable operating cycle under the specifications set in this catalog is shown below.

1.2 million times RB08

2 million times RB10 to RB2725

Note 1) Specified service life (suitable replacement period) is the value at room temperature (20 to 25°C). The period may vary depending on the temperature and other conditions. In some cases the absorber may need to be replaced before the allowable operating cycle above.

Clean Rodless Cylinder

Series *CYP*

ø15, ø32

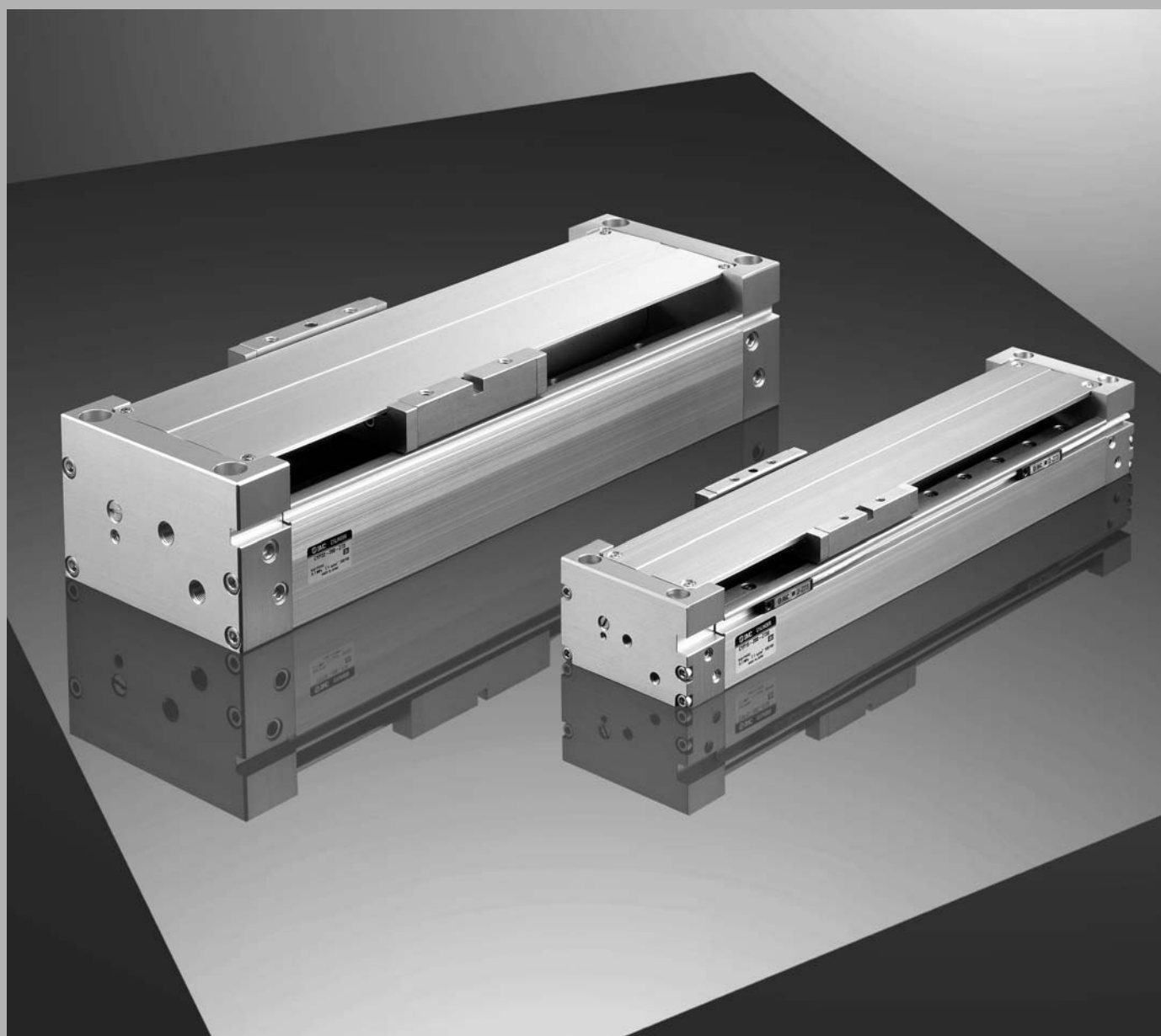

CY3B
CY3R

CY1S

CY1L

CY1H

CY1F

CYP

Magnetically coupled rodless cylinder for transfer in clean environments.

D-□

-X□

Individual
-X□

Technical
data

A magnetically coupled rodless cylinder that can

Low particle generation: 1/20 (compared to previous series)

- High cleanliness is achieved with **non-contact construction** of the cylinder tube exterior and a **stainless steel linear guide (specially treated)**.
- Particle generation has been reduced to 1/20 compared to series 12-CY3B (previous SMC product) even without vacuum suction.

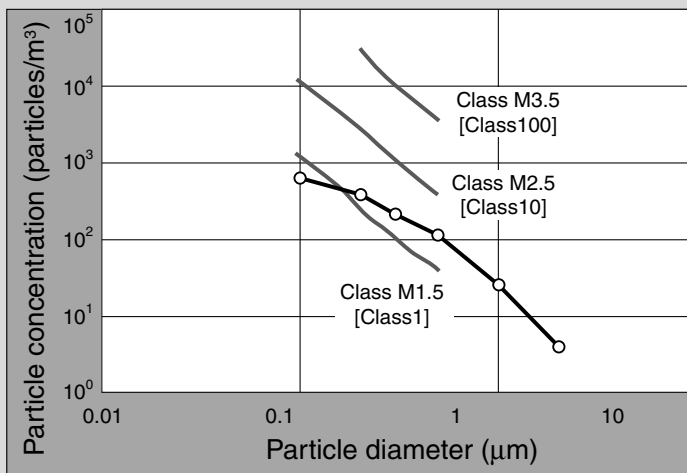

- Note 1) This chart indicates the level of cleanliness inside the measurement chamber.
 Note 2) The vertical axis shows the number of particles per unit volume (1 m³) of air which are no smaller than the particle size shown on the horizontal axis.
 Note 3) The gray lines show the upper concentration limit of the cleanliness class based on Fed.Std.209E-1992.
 Note 4) The plots indicate the 95% upper reliability limit value for time series data up to 500 thousand operation cycles. (Cylinder: CYP32-200, Workpiece weight: 5 kg, Average speed: 200 mm/s)
 Note 5) The data above provide a guide for selection but is not guaranteed.

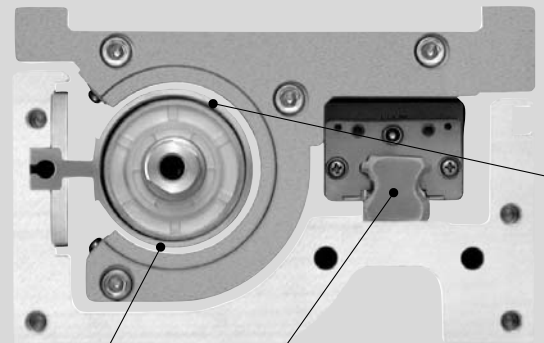

Stainless steel linear guide (specially treated)

The specially treated linear guide achieves low particulate generation, high linearity and high precision.

Non-contact construction

There is no particulate generation from sliding, because the construction avoids contact between the cylinder tube's exterior surface and the slide table's interior surface.

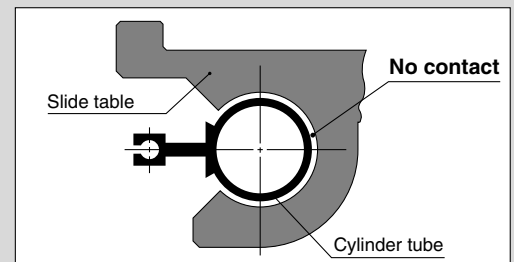

Piping port variations provide a high degree of freedom

Piping port positions can be selected to accommodate the installation.

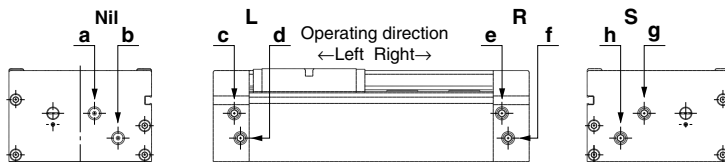

Note) Plugs are installed in ports other than those indicated for the model.

Model	Nil		L		R		S	
Piping port position	a	b	c	d	e	f	g	h
Operating direction	Right	Left	Right	Left	Right	Left	Right	Left



Cleaned, assembled and double packaged in a clean room

be used for transfer in clean environments

Long stroke (Max. 700 mm)

Special cylinder tube

A special cylinder tube is employed using extruded aluminum material. Even long strokes are not subject to deflection because of direct attachment to the cylinder body, and non-contact construction is achieved through combination with a linear guide.



Shock-free

A **sine cushion** is used at the end of the stroke. Smooth acceleration and deceleration are possible at 5 m/s² or less.

Sine cushion

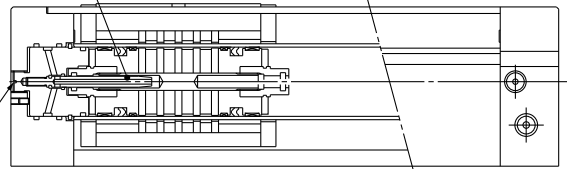

Stroke adjustment screw

Stroke adjustment

The **stroke adjustment screw** allows fine control of the stroke (± 1 mm on each side)



Series Variations

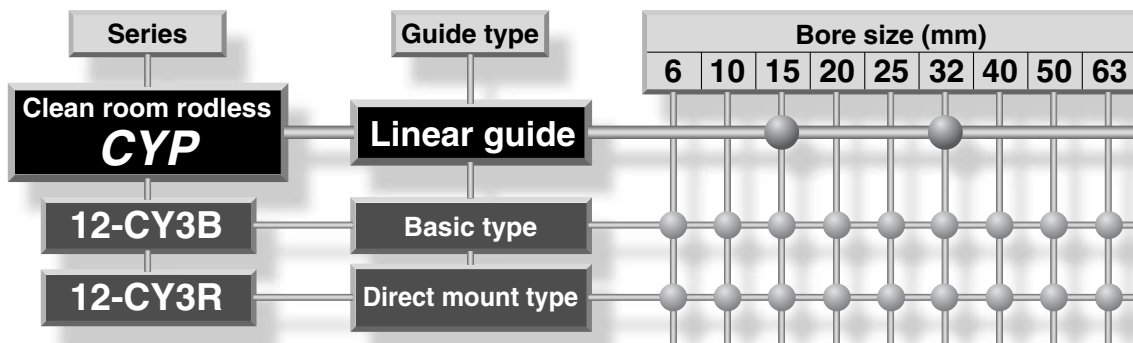
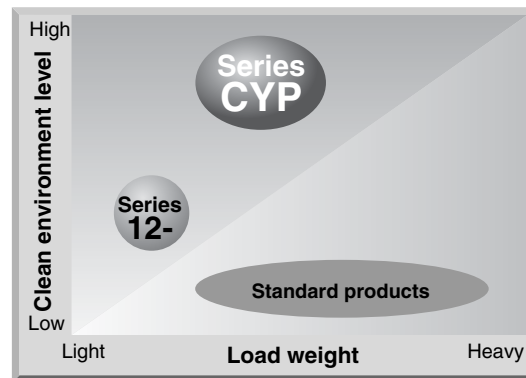

* For details about series 12-, refer to the catalog, "SMC Pneumatic Clean Series."

CY3B
CY3R

CY1S

CY1L

CY1H

CY1F

CYP

D-□

-X□

Individual
-X□

Technical
data

Series CYP Model Selection 1

Caution on Design (1)

The load mass allowable moment differs depending on the workpiece mounting method, cylinder mounting orientation and piston speed. In making a determination of usability, do not allow the sum ($\Sigma\alpha_n$) of the load factors (α_n) for each mass and moment to exceed "1".

$$\Sigma\alpha_n = \frac{\text{Load mass (m)}}{\text{Max. load mass (m max)}} + \frac{\text{Static moment (M)}}{\text{Allowable static moment (M max)}} + \frac{\text{Dynamic moment (Me)}}{\text{Allowable dynamic moment (Me max)}} \leq 1$$

Load Mass

Max. load mass (kg)

Model	m max
CYP15	1
CYP32	5

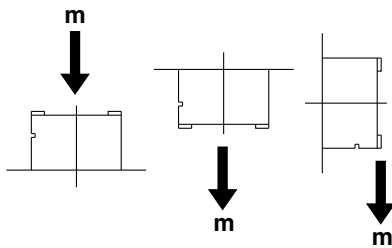

Moment

Allowable moment
(Static moment/Dynamic moment)

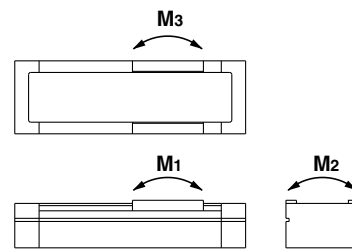

Model	M1	M2	M3
CYP15	0.3	0.6	0.3
CYP32	3	4	3

Static Moment

Moment generated by the workpiece weight even when the cylinder is stopped

■ Pitch moment

$$M_1 = m \times g \times (L + B) \times 10^{-3}$$

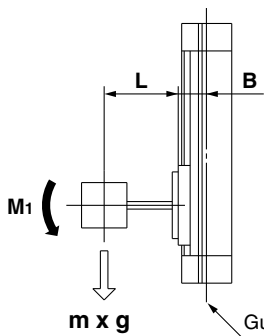

■ Roll moment

$$M_2 = m \times g \times (L + B) \times 10^{-3}$$

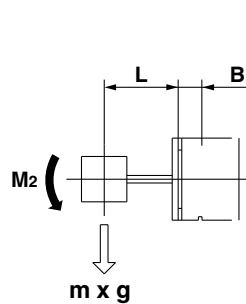

■ Yaw moment

$$M_3 = m \times g \times (L + A) \times 10^{-3}$$

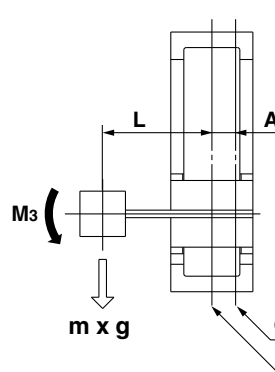

Model	A	B
CYP15	16.5	25.5
CYP32	27.0	48.0

M_{1, 2, 3} : Moment [N·m]
m : Load mass [kg]
L : Distance to load center of gravity [mm]
A, B : Distance to guide shaft [mm]
g : Gravitational acceleration [9.8 m/s²]

Dynamic Moment

Moment generated by the load equivalent to impact at the stroke end

$$We = 5 \times 10^{-3} \times m \times g \times U$$

We: Load equivalent to impact [N]
m : Load mass [kg]
U: Max. speed [mm/s]
g: Gravitational acceleration [9.8 m/s²]

■ Pitch moment

$$Me_1 = 1/3 * We (L + B) \cdot 10^{-3}$$

* Average load coefficient

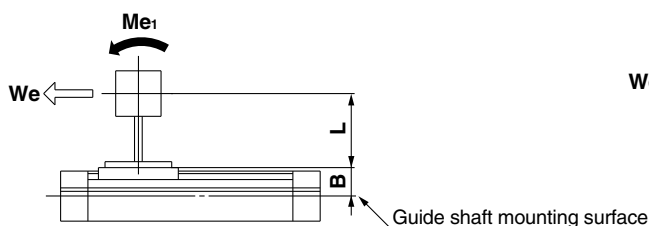

■ Yaw moment

$$Me_3 = 1/3 * We (L + A) \cdot 10^{-3}$$

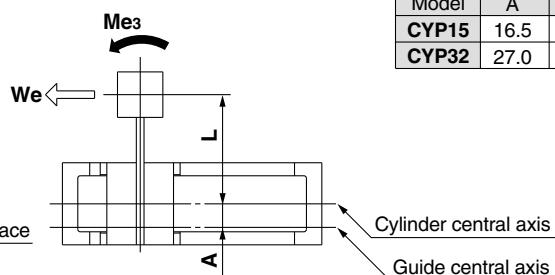

Model	A	B
CYP15	16.5	25.5
CYP32	27.0	48.0

Series CYP Model Selection 2

Selection Calculation

The selection calculation finds the load factors (α_n) of the items below, where the total ($\sum \alpha_n$) does not exceed 1.

$$\sum \alpha_n = \alpha_1 + \alpha_2 + \alpha_3 \leq 1$$

Item	Load factor α_n	Note
1. Max. load mass	$\alpha_1 = m/m_{\max}$	Review m m _{max} is the maximum load mass
2. Static moment	$\alpha_2 = M/M_{\max}$	Review M1, M2, M3 M _{max} is the allowable moment
3. Dynamic moment	$\alpha_3 = Me/M_{\max}$	Review Me1, Me3 Me _{max} is the allowable moment

Calculation Example

Operating Conditions

Cylinder: CYP32
 Mounting: Horizontal wall mounting
 Maximum speed: U = 300 [mm/s]
 Load mass: m = 1 [kg] (excluding mass of arm section)
 L1 = 50 [mm]
 L2 = 50 [mm]

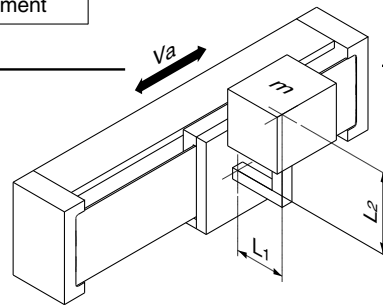

Item	Load factor α_n	Note
1. Maximum load mass 	$\alpha_1 = m/m_{\max}$ $= 1/5$ $= 0.20$	Review m.
2. Static moment 	$M_2 = m \cdot g \cdot (L_1 + B) \cdot 10^{-3}$ $= 1 \cdot 9.8 \cdot (50 + 48) \cdot 10^{-3}$ $= 0.96 \text{ [N}\cdot\text{m]}$ $\alpha_2 = M_2/M_2 \text{ max}$ $= 0.96/4$ $= 0.24$	Review M2. Since M1 & M3 are not generated, review is unnecessary.
3. Dynamic moment 	$We = 5 \times 10^{-3} m \cdot g \cdot U$ $= 5 \times 10^{-3} \cdot 1 \cdot 9.8 \cdot 300$ $= 14.7 \text{ [N]}$ $Me_3 = 1/3 \cdot We \cdot (L_2 + A) \cdot 10^{-3}$ $= 1/3 \cdot 14.7 \cdot (50 + 27) \cdot 10^{-3}$ $= 0.38 \text{ [N}\cdot\text{m]}$ $\alpha_3 = Me_3/Me_3 \text{ max}$ $= 0.38/3$ $= 0.13$	Review Me3.
	$Me_1 = 1/3 \cdot We \cdot (L_1 + B) \cdot 10^{-3}$ $= 1/3 \cdot 14.7 \cdot (50 + 48) \cdot 10^{-3}$ $= 0.48 \text{ [N}\cdot\text{m]}$ $\alpha_4 = Me_1/Me_1 \text{ max}$ $= 0.48/3$ $= 0.16$	Review Me1.

$$\begin{aligned} \sum \alpha_n &= \alpha_1 + \alpha_2 + \alpha_3 + \alpha_4 \\ &= 0.20 + 0.24 + 0.13 + 0.16 \\ &= 0.73 \\ \sum \alpha_n &= 0.73 \leq 1 \text{ Therefore it can be used.} \end{aligned}$$

CY3B
CY3R

CY1S

CY1L

CY1H

CY1F

CYP

D-

-X

Individual
-X

Technical
data

Series CYP Model Selection 3

Caution on Design (2)

Table Deflection Note)

Table deflection due to pitch moment load

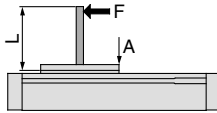

$$M_1 = F \times L$$

Table deflection due to roll moment load

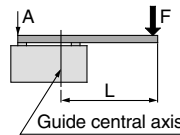

$$M_2 = F \times L$$

Table deflection due to yaw moment load

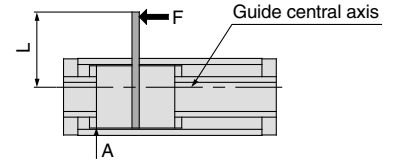

$$M_3 = F \times L$$

Note) Displacement of Section A when force acts on Section F

CYP15 (M1)

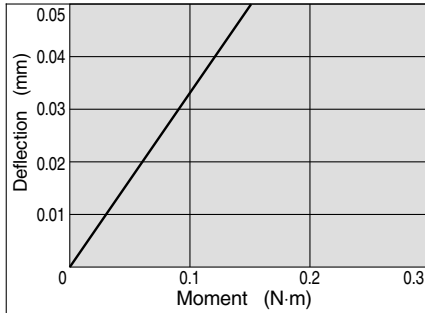

CYP15 (M2)

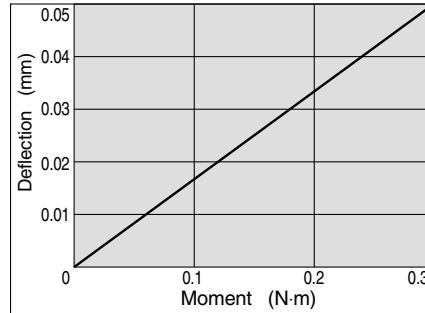

CYP15 (M3)

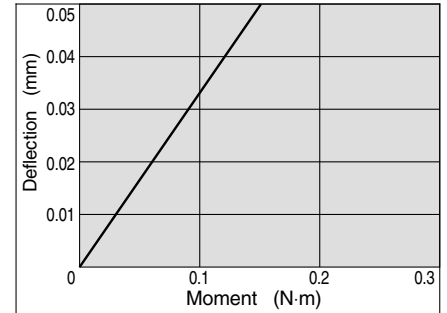

CYP32 (M1)

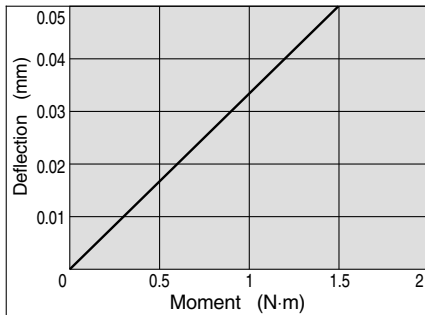

CYP32 (M2)

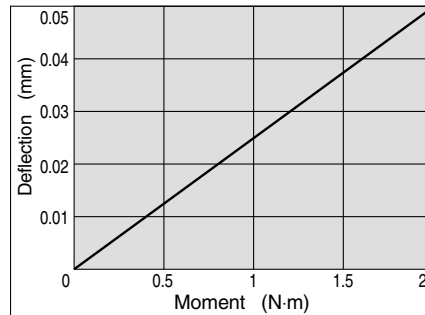

CYP32 (M3)

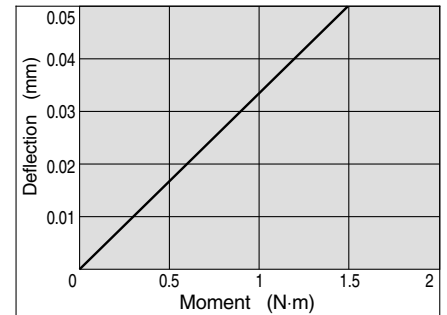

Note) Extend lines in the graphs to indicate amount of deflection when moments larger than the above are applied.

Vertical Operation

When using in vertical operation, prevention of workpiece dropping due to breaking of the magnetic coupling should be considered. The allowable load mass and maximum operating pressure should be as shown in the table below.

When the cylinder is mounted vertically or sideling, a slider may move downwards due to the self-weight or workpiece mass. If an accurate stopping position is required at the stroke end or the middle of stroke, use an external stopper to secure the accurate positioning.

Model	Allowable load mass mv (kg)	Maximum operating pressure Pv (MPa)
CYP15	1	0.3
CYP32	5	

Intermediate Stop

The cushion effect (smooth start-up, soft stop) exists only before the stroke end in the stroke ranges indicated in the table below.

The cushion effect (smooth start-up, soft stop) cannot be obtained in an intermediate stop or return from an intermediate stop using an external stopper, etc.

When using an intermediate stop considering the above information, implement measures to prevent particulate generation and set the operating pressure to no more than 0.3 MPa.

Cushion Stroke

Model	Stroke (mm)
CYP15	25
CYP32	30

Clean Rodless Cylinder

Series CYP

ø15, ø32

How to Order

CYP 15 - 200 - Y7BW

Clean room rodless cylinder

Bore size

15	15 mm
32	32 mm

Standard stroke

Bore size (mm)	Standard stroke (mm)
15, 32	100, 150, 200, 250, 300, 350 400, 450, 500, 600, 700

Number of auto switches

Nil	2 pcs.
S	1 pc.
n	"n" pcs.

Auto switch

Nil	Without auto switch (Built-in magnet)
-----	---------------------------------------

For the applicable auto switch model, refer to the table below.

Piping port location

Nil	a	Operating direction: Right
	b	Operating direction: Left
L	c	Operating direction: Right
	d	Operating direction: Left
R	e	Operating direction: Right
	f	Operating direction: Left
S	g	Operating direction: Right
	h	Operating direction: Left

Note 1) Please consult with SMC if the maximum stroke is exceeded.

Note 2) Intermediate strokes are available as a special order.

Piping Port Location

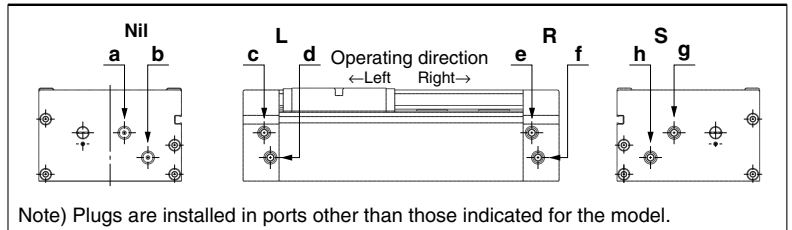

Applicable Auto Switch

Type	Special function	Electrical entry	Indicator light	Wiring (Output)	Load voltage		Auto switch model		Lead wire length (mm)*			Pre-wired connector	Applicable load			
					DC	AC	Electrical entry direction	In-line	0.5 (Nil)	3 (L)	5 (Z)					
Solid state switch	—	Grommet	Yes	3-wire (NPN)	24 V	5 V, 12 V	—	Y69A	Y59A	●	●	○	○	IC circuit		
				3-wire (PNP)				Y7PV	Y7P	●	●	○				
	Diagnostic indication (2-color indication)			Grommet	Yes	2-wire	24 V	12 V	—	Y69B	Y59B	●	●	○	○	—
						3-wire (NPN)				Y7NWV	Y7NW	●	●	○		
						3-wire (PNP)	Y7PWV	Y7PW	●	●	○	○	IC circuit			
						2-wire	Y7BWV	Y7BW	●	●	○					
Reed switch	—	Grommet	Yes	3-wire	24 V	5 V	—	—	Z76	●	●	—	—	IC circuit	—	
				2-wire		12 V	100 V	—	Z73	●	●	●	—	—	Relay, PLC	
				No	5 V, 12 V	100 V or less	—	Z80	●	●	—	—	—	IC circuit	—	

* Lead wire length symbols: 0.5 m Nil (Example) Y7BW
3 m L Y7BWL
5 m Z Y7BWZ

** Auto switches marked with a "O" symbol are produced upon receipt of order.

- Refer to pages 1328 and 1329 for the details of auto switches with a pre-wired connector.
- Normally closed (NC = b contact) solid state auto switches (D-Y7G/Y7H types) are also available. Refer to page 1292 for details.
- * Auto switches are shipped together, (but not assembled).

CY3B
CY3R

CY1S

CY1L

CY1H

CY1F

CYP

D-□

-X□

Individual
-X□

Technical
data

Series CYP



Specifications

Bore size (mm)	15	32
Fluid ^{Note 1)}	Air/Inert gas	
Action	Double acting	
Proof pressure	0.5MPa	
Operating pressure range	0.05 to 0.3MPa	
Ambient and fluid temperature	-10 to 60°C	
Piston speed (Max.) ^{Note 2)}	50 to 300mm/s	
Lubrication	Not required (Non-lube)	
Stroke adjustment	±1mm on each side (±2mm total)	
Cushion	Sine cushion (Air cushion)	
Port size	M5 x 0.8	Rc (PT) 1/8
Magnet holding force (N)	59	268

Note 1) Air is recommended for the operating environmental atmosphere and operating fluid. When using other fluids and inert gas, contact SMC for the product service life since it may vary.

Note 2) The piston speed above indicates the maximum speed. It takes approx. 0.5 seconds for a single side and approx. 1 second for both sides for a sliding table to move through the cushion stroke starting from the stroke end.

Mass

Model	Standard stroke (mm)										
	100	150	200	250	300	350	400	450	500	600	700
CYP15	1.2	1.4	1.6	1.7	1.9	2.0	2.2	2.4	2.5	2.8	3.2
CYP32	4.2	4.6	5.0	5.5	5.9	6.3	6.7	7.1	7.5	8.3	9.1

(kg)

Theoretical Output

Bore size (mm)	Piston area (mm ²)	Operating pressure (MPa)		
		0.1	0.2	0.3
15	176	18	35	53
32	804	80	161	241

(N)

Construction

CYP15

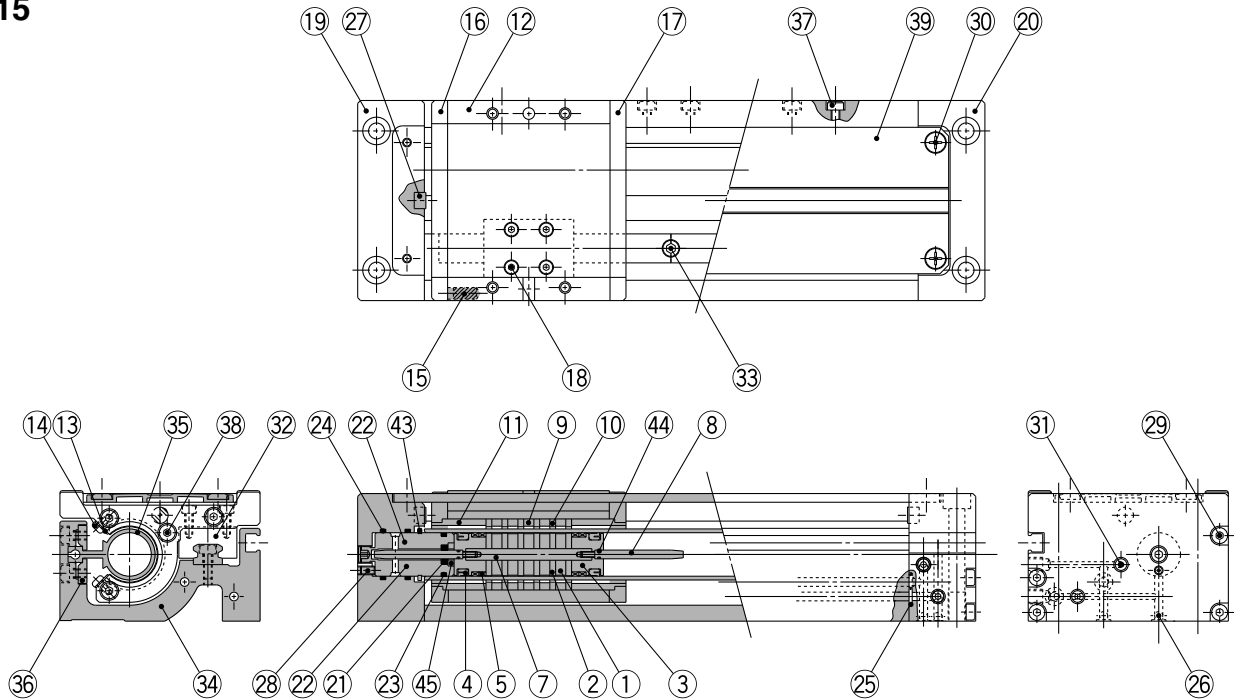

CYP32

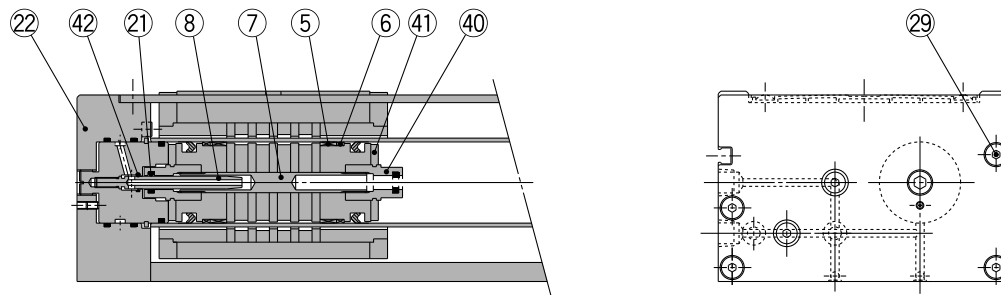

Component Parts

No.	Description	Material	Note
1	Magnet A	—	
2	Piston side yoke	Rolled steel plate	Zinc chromated
3	Piston	Brass/Aluminum alloy	ø15: Electroless nickel plated, ø32: Chromated
4	Piston seal	NBR	
5	Wear ring A	Special resin	
6	Wear ring	Special resin	
7	Shaft	Stainless steel	
8	Cushion ring	Stainless steel/Brass	ø15: Electroless nickel plated
9	Magnet B	—	
10	External slider side yoke	Rolled steel	Electroless nickel plated
11	Hold spacer	Aluminum alloy	Electroless nickel plated
12	Slide table	Aluminum alloy	Electroless nickel plated
13	Insertion guide plate	Stainless steel	
14	Round head Phillips screw	Carbon steel	Nickel plated
15	Magnet	—	
16	Side plate A	Aluminum alloy	Electroless nickel plated
17	Side plate B	Aluminum alloy	Electroless nickel plated
18	Hexagon socket head cap screw	Chrome molybdenum steel	Nickel plated
19	Plate A	Aluminum alloy	Clear hard anodized
20	Plate B	Aluminum alloy	Clear hard anodized
21	Cushion seal	NBR	
22	Inner cover	Aluminum alloy	Clear hard anodized

No.	Description	Material	Note
23	Cylinder tube gasket	NBR	
24	O-ring	NBR	
25	O-ring	NBR	
26	Steel ball	Carbon steel	
27	Bumper	Polyurethane	
28	Hexagon socket head set screw	Chrome molybdenum steel	Nickel plated
29	Hexagon socket head cap screw	Chrome molybdenum steel	Nickel plated
30	Round head Phillips screw	Stainless steel	Nickel plated
31	Hexagon socket head plug	Chrome molybdenum steel	Nickel plated
32	Linear guide	Stainless steel	
33	Hexagon socket head cap screw	Chrome molybdenum steel	Nickel plated
34	Body	Aluminum alloy	Clear hard anodized
35	Cylinder tube	Aluminum alloy	Hard anodized
36	Tube attaching bracket	Aluminum alloy	Clear hard anodized
37	Hexagon socket head cap screw	Chrome molybdenum steel	Nickel plated
38	Hexagon socket head cap screw	Chrome molybdenum steel	Nickel plated
39	Top cover	Aluminum alloy	Clear hard anodized
40	Cushion seal holder	Aluminum alloy	Chromated
41	Bumper	Urethane	CYP32 only
42	O-ring	NBR	
43	Type C retaining ring for axis	Carbon tool steel	
44	O-ring	NBR	
45	Retaining plate	Aluminum alloy	CYP15 only

CY3B
CY3R

CY1S

CY1L

CY1H

CY1F

CYP

D-□

-X□

Individual

-X□

Technical data

Series CYP

Dimensions

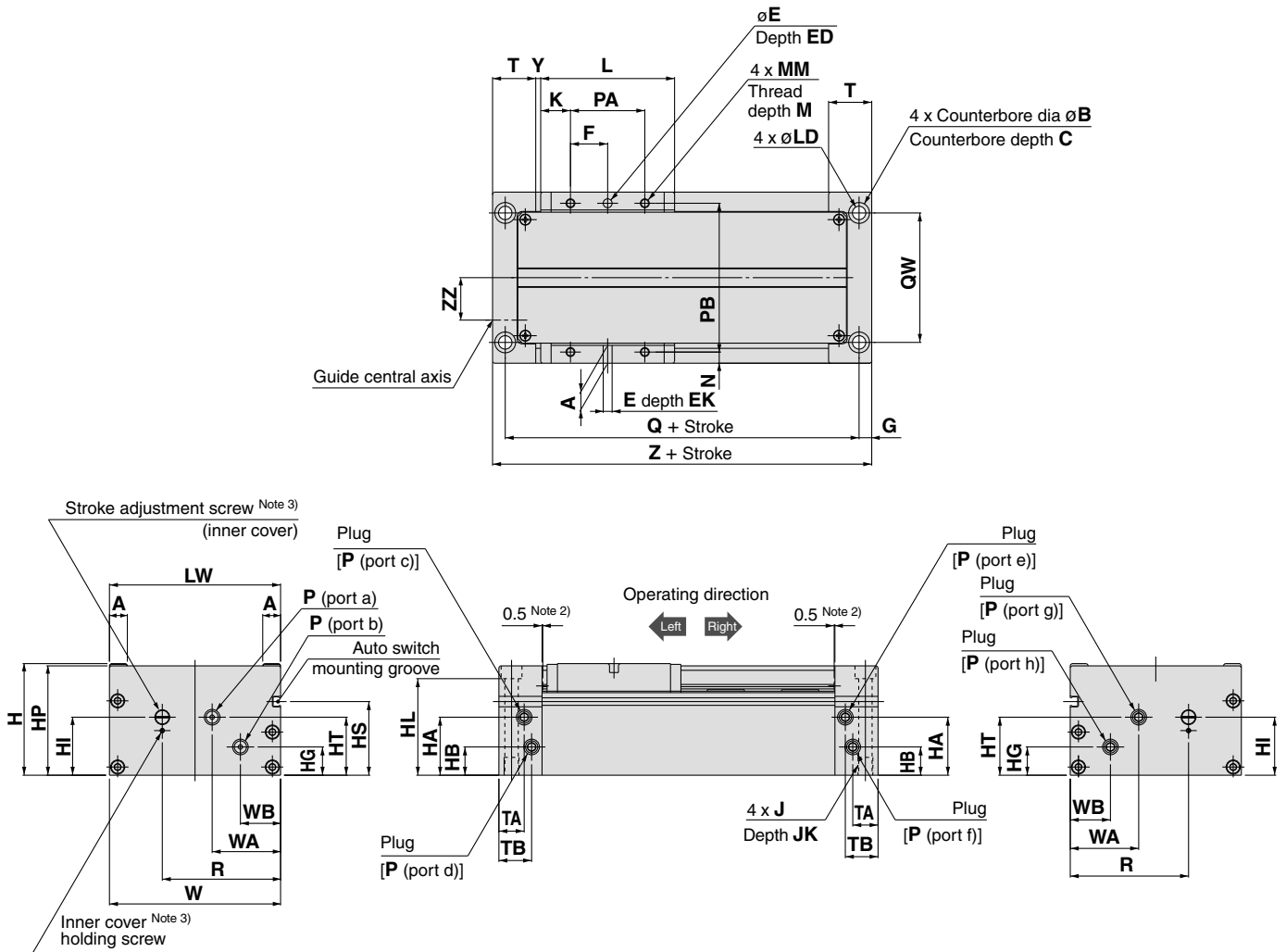

(mm)

Model	A	B	C	E	ED	EK	F	G	H	HA	HB	HG	HI	HL	HP	HS	HT	J	JK	K	L
CYP15	8	9.5	5.4	4H9 ^{+0.030} ₀	9.5	4	12.5	6.5	45	19.5	8.5	8.5	23	38.6	44	27	19.5	M6 x 1	10	21	67
CYP32	12	14	8.6	6H9 ^{+0.030} ₀	13	6	25	8.5	75	39	19	19	39	64.9	73.5	49.5	39	M10 x 1.5	12	20	90

Model	LD	LW	MM	M	N	P	PA	PB	Q	QW	R	T	TA	TB	W	WA	WB	Y	Z	ZZ
CYP15	5.6	69	M4 x 0.7	6	4.5	M5 x 0.8	25	60	105	48	45	23	13	18	69	32	17	2.5	118	16.5
CYP32	9.2	115	M6 x 1	8	7.5	Rc (PT) 1/8	50	100	138	87	79.5	29	17	22	115	46	27	3.5	155	29

Note 1) These dimension drawings indicate the case of piping port location "Nil".

Note 2) These dimensions indicate the protruding portion of the bumper.

Note 3) Refer to "Specific Product Precautions" [Cushion Effect (Sine Cushion) and Stroke Adjustment] on page 1261.

Model	Nil	L	R	S				
Piping port location	a	b	c	d	e	f	g	h
Operating direction	Right	Left	Right	Left	Right	Left	Right	Left

Proper Auto Switch Mounting Position Detection (Detection at stroke end)

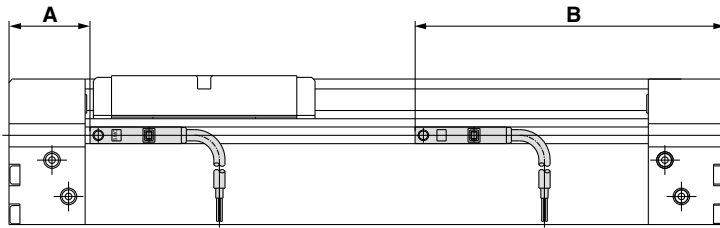

Operating Range

Auto switch model \ Cylinder model	D-Z7□ D-Z80	D-Y7□W D-Y7□WV D-Y5□ D-Y6□ D-Y7P D-Y7PV
	CYP15	6.5
CYP32	9.5	3

Note) Operating ranges are standards including hysteresis, and are not guaranteed. (variations on the order of ±30%)
Large variations may occur depending on the surrounding environment.

Proper Auto Switch Mounting Position

Auto switch model \ Cylinder model	A			B		
	D-Z7□ D-Z80	D-Y7□W D-Y7□WV	D-Y5□ D-Y6□ D-Y7P D-Y7PV	D-Z7□ D-Z80	D-Y7□W D-Y7□WV	D-Y5□ D-Y6□ D-Y7P D-Y7PV
CYP15	24.5			93.5		
CYP32	33			122		

Note) Adjust the auto switch after confirming the operating conditions in the actual setting.

Mounting of Auto Switch

When mounting auto switches, they should be inserted into the cylinder's auto switch installation groove from the direction shown in the drawing on the right. After setting in the mounting position, use a flat head watchmaker's screwdriver to tighten the auto switch mounting screw which is included.

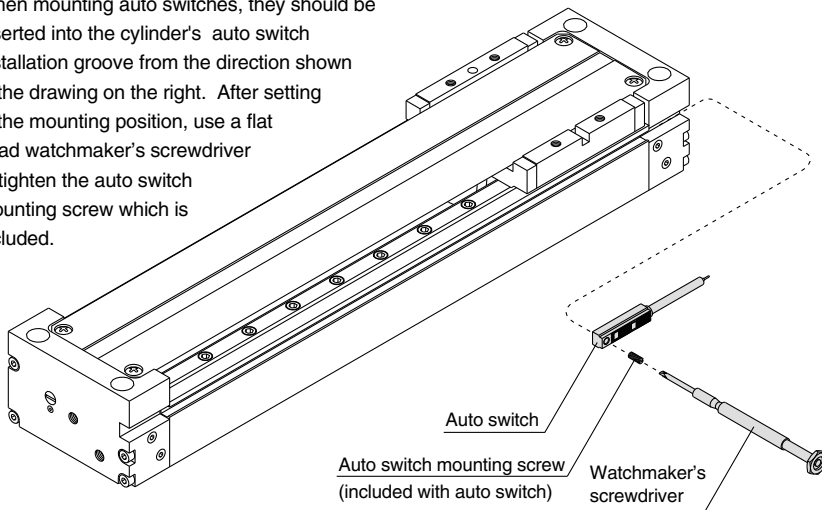

Note) When tightening the auto switch mounting screw (included with the auto switch), use a watchmaker's screwdriver with a handle about 5 to 6 mm in diameter. The tightening torque should be approximately 0.05 to 0.1 N·m.

CY3B
CY3R

CY1S

CY1L

CY1H

CY1F

CYP

D-□

-X□

Individual
-X□

Technical
data



Series CYP

Specific Product Precautions 1

Be sure to read before handling.

Refer to front matters 54 and 55 for Safety Instructions and pages 3 to 11 for Actuator and Auto Switch Precautions.

Handling

Caution

1. Open the inner package of the double packaged clean series inside a clean room or other clean environment.
2. Perform parts replacement and disassembly work in a clean room after exhausting compressed air in the piping outside the clean room.

Mounting

Caution

1. **Take care to avoid striking the cylinder tube with other objects or handling it in a way that could cause deformation.**
The cylinder tube and slider units have a non-contact construction. For this reason, even a slight deformation or slippage of position can cause malfunction and loss of durability, as well as a danger of degrading the particulate generation characteristics.
2. **Do not scratch or gouge the linear guide by striking it with other objects.**
Since the linear guide is specially treated for maximum suppression of particulate generation due to sliding, even a slight scratch can cause malfunction and loss of durability, as well as a danger of degrading the particulate generation characteristics.
3. **Since the slide table is supported by precision bearings, do not apply strong impacts or excessive moment when mounting workpieces.**
The slide table may contact with the cylinder tube.
4. **Be sure to operate the cylinder with the plates on both sides secured.**
Avoid applications in which the slide table or only one plate is secured.
5. **When changing the ports to be used, be sure that unused ports are securely sealed.**
Take sufficient care in sealing unused ports, because if ports are not properly sealed air can leak from the ports and particulate generation characteristics can be degraded.
6. **Do not loosen the bolts that fix the block of the linear guide and slide table.**
The slide table may contact with the cylinder tube.
7. **It is recommended to place the load's center of gravity on the cylinder linear guide.**
The linear guide position is off-set from the cylinder center axis, so it is recommended to place the load's center of gravity on the linear guide.

Operation

Caution

1. **The maximum operating pressure for the clean rodless cylinder is 0.3 MPa.**
If the maximum operating pressure of 0.3 MPa for the clean rodless cylinder is exceeded, the magnetic coupling can be broken, causing a danger of malfunction or degradation of particulate generation characteristics, etc.
2. **The product can be used with a direct load applied within the allowable range, but careful alignment is necessary when connecting to a load having an external guide mechanism.**
Since alignment variations increase as the stroke gets longer, use a connection method which can absorb these variations and consider measures to control particulate generation.
3. **When used for vertical operation, use caution regarding possible dropping due to separation of the magnetic coupling.**
When used for vertical operation, use caution as there is a possibility of dropping due to separation of the magnetic coupling if a load (pressure) greater than the allowable value is applied.
4. **Do not operate with the magnetic coupling out of position.**
If the magnetic coupling is out of position, push the external slider by hand (or the piston slider with air pressure) back to the proper position at the stroke end.
5. **Do not supply lubrication, as this is a non-lube product.**
The interior of the cylinder is lubricated at the factory, and lubrication with turbine oil, etc., will not satisfy the product's specifications.



Series CYP Specific Product Precautions 2

Be sure to read before handling.

Refer to front matters 54 and 55 for Safety Instructions and pages 3 to 11 for Actuator and Auto Switch Precautions.

Speed Adjustment

Caution

1. A throttle valve for clean room use is recommended for speed adjustment. (Please consult with SMC regarding equipment and methods to be used.)

Speed adjustment can also be performed with a meter-in or meter-out type speed controller for clean room use, but it may not be possible to obtain smooth starting and stopping operation.

Throttle Valves and Dual Speed Controllers for Recommended Speed Adjustment of CYP Cylinders

Throttle valve	Series	Model	
		CYP15	CYP32
Metal body piping type	Elbow type	10-AS1200-M5-X216	10-AS2200-01-X214
	In-line type	10-AS1000-M5-X214	10-AS2000-01-X209
Resin body with One-touch fitting	Elbow type (throttle valve)	10-AS1201F-M5-04-X214	10-AS2201F-01-04-X214
		10-AS1201F-M5-06-X214	10-AS2201F-01-06-X214
		10-AS2201F-01-08-X214	
	Universal type (throttle valve)	10-AS1301F-M5-04-X214	10-AS2301F-01-04-X214
		10-AS1301F-M5-06-X214	10-AS2301F-01-06-X214
			10-AS2301F-01-08-X214
	In-line type (throttle valve)	10-AS1001F-04-X214	10-AS2001F-04-X214
		10-AS1001F-06-X214	10-AS2001F-06-X214
Dual type (speed controller)	10-ASD230F-M5-04	10-ASD330F-01-06	
	10-ASD230F-M5-06	10-ASD330F-01-08	
With clean One-touch fitting	Elbow type/Brass (throttle valve)	AS1201FPQ-M5-04-X214	AS2201FPQ-01-04-X214
		AS1201FPQ-M5-06-X214	AS2201FPQ-01-06-X214
		—	AS2201FPQ-01-08-X214
	Elbow type/Stainless steel 304 (throttle valve)	AS1201FPG-M5-04-X214	AS2201FPG-01-04-X214
		AS1201FPG-M5-06-X214	AS2201FPG-01-06-X214
		—	AS2201FPG-01-08-X214

Note 1) Refer to Back Page 10 (How to Use Clean Series) for the selection of the metal body piping type and the cylinders with a resin-body one-touch fitting.

Note 2) Refer to the Pneumatic Clean Series (fittings for air line equipment) for the fittings used for the metal body piping type.

2. In the case of vertical mounting, a system with a reduced pressure supply circuit installed on the down side is recommended. (This is effective against upward starting delays and for conservation of air.)

Cushion Effect (Sine Cushion) and Stroke Adjustment

Caution

1. A sine cushion (smooth start, soft stop) function is included in the standard specifications.

Due to the nature of a sine cushion, adjustment of the cushion effect is not possible. There is no cushion needle adjustment as in the case of conventional cushion mechanisms.

2. The stroke end adjustment is a mechanism to adapt the slide table's stroke end position to a mechanical stopper on other equipment, etc.

(Adjustment range: Total of both sides ± 2 mm) To ensure safety, perform adjustment after shutting off the drive air, releasing the residual pressure and implementing drop prevention measures, etc.

- 1) Loosen the inner cover holding screw with a hexagon wrench. (When adjusting strokes, be sure to adjust after loosening set screws. If rotating stroke adjustment screws without loosening them, hexagon holes for adjustment screws may deform and stroke adjustment cannot be performed.)
- 2) To match the position with a mechanical stopper on other equipment, etc., rotate the stroke adjustment screws of the inner cover with a hexagon wrench and move the inner cover back and forth in the axial direction. Approximately 1 mm of adjustment is possible with one rotation. (Stroke adjustment screw rotational direction: Left rotation \rightarrow +stroke, Right rotation \rightarrow -stroke)
- 3) The maximum adjustment on one side is ± 1 mm. A total adjustment of approximately ± 2 mm is possible using both sides.
- 4) After adjusting the set stroke, tighten the inner cover holding screw with a hexagon wrench.

Inner Cover Holding Screw Tightening Torque [N·m] and Hexagon Wrench

Model	Inner cover holding screw			Stroke adjustment screw
	Screw size	Tightening torque	Hexagon wrench (Nominal size)	Hexagon wrench (Nominal size)
CYP15	M3 x 0.5	0.3	1.5	2.5
CYP32	M6 x 1	2.45	3	4

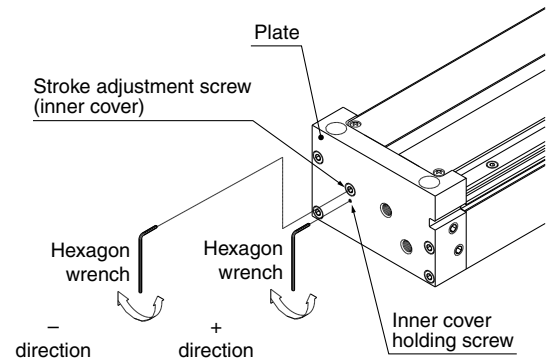

CY3B
CY3R

CY1S

CY1L

CY1H

CY1F

CYP

D-□

-X□

Individual
-X□

Technical
data



Series CYP

Specific Product Precautions 3

Be sure to read before handing.

Refer to front matters 54 and 55 for Safety Instructions and pages 3 to 11 for Actuator and Auto Switch Precautions.

Maintenance

⚠ Caution

1. Never disassemble the cylinder tube or linear guide, etc.

If disassembled, the slide table may touch the outside surface of the cylinder tube resulting in a degradation of particulate generation characteristics.

2. Cylinder maintenance should be performed roughly at the operating cycle of 500 thousand or operating distance of 400 km.

Particulate Generation Characteristics

⚠ Caution

1. In order to maintain the particulate generation grade, use operation of 500 thousand cycles or travel distance of about 400 km as a standard. (Graph (1) below)

If operation is continued beyond the recommended values, lubrication failure of the linear guide and loss of particulate generation characteristics may occur.

Graph (1)

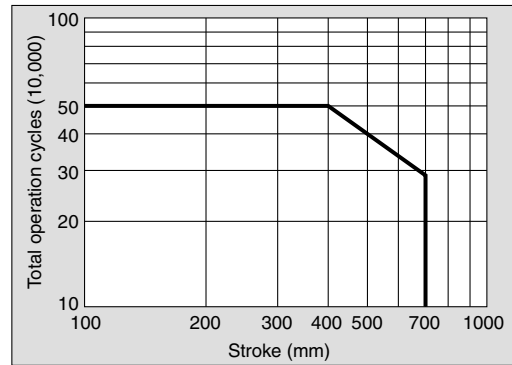

Graph (2)

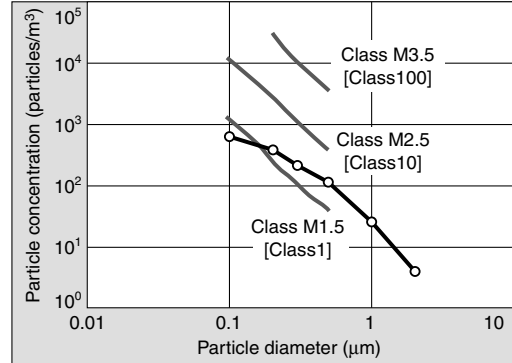

Note 1) This chart indicates the level of cleanliness inside the measurement chamber.

Note 2) The vertical axis shows the number of particles per unit volume (1 m³) of air which are no smaller than the particle size shown on the horizontal axis.

Note 3) The gray lines show the upper concentration limit of the cleanliness class based on Fed. Std. 209E-1992.

Note 4) The plots indicate the 95% upper reliability limit value for time series data up to 500 thousand operation cycles. (Cylinder: CYP32-200, Workpiece weight: 5 kg, Average speed: 200 mm/s)

Note 5) The data above provides a guide for selection but is not guaranteed.

2. When the amount of grease at the linear guide is insufficient depending on the operating conditions, regular application of grease is recommended.

In such cases, the amount of dust may temporarily increase. After operating the cylinder for a short period of time, increased dust gradually decreases.

Rodless Cylinder for Vacuum

Series CYV

ø15, ø32

Air cylinder for transfer in vacuum environments (1.3×10^{-4} Pa)



XL□

XL□Q

XM□
XY□

D-□

XVD

XGT

CYV

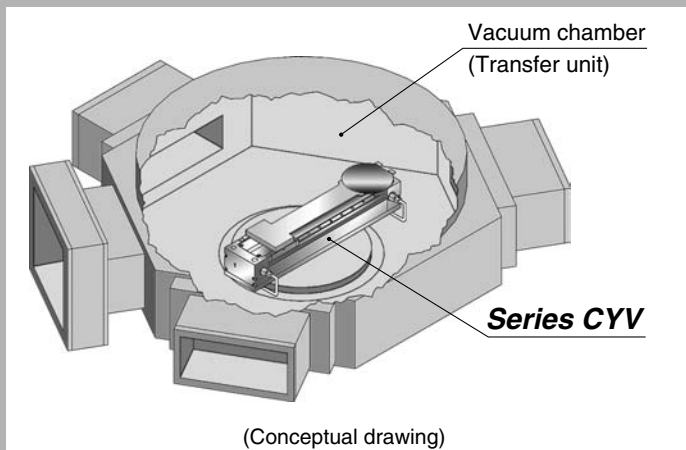

Simplifies and reduces the size of equipment

Since the cylinder can be installed inside a vacuum chamber, it contributes to simplifying and reducing the size of a transfer system.

Note) The illustration above is an example showing how to install the rodless cylinder.
However, it is only an image, and does not satisfy all the required conditions for using a vacuum chamber.

Rodless Cylinder for Vacuum

Series CYV
 ø15, ø32

Air cylinder for transfer

Carefully designed for low particulate generation,

Low particulate generation

Average particle generation (particles > 0.1 μ) is 0.1 particles/cycle. (Atmospheric conditions)

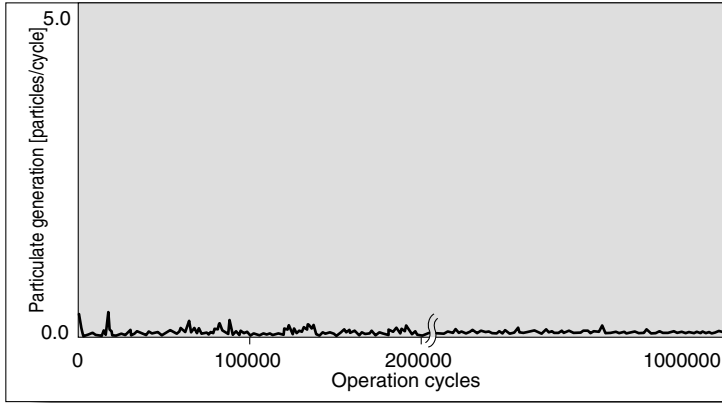

Note 1) This data indicates deterioration with age of the average number of particles per operation under the following test conditions.

<Test conditions>

- **Cylinder:** CYV32-100
- **Average speed:** 100 mm/s
- **Measurement environment:** Operation in the atmosphere afterbaking at 150°C for 48 hours.
- **Workpiece mass:** 5 kg

Note 2) This data is considered typical but not guaranteed.

Note 3) A particulate generation test has been conducted in a vacuum environment of 10^{-6} Pa.

Low particulate generation

1

Non-contact construction

There is no particulate generation due to friction, since the construction does not allow contact between the cylinder tube's exterior surface and the slide table's internal surface.

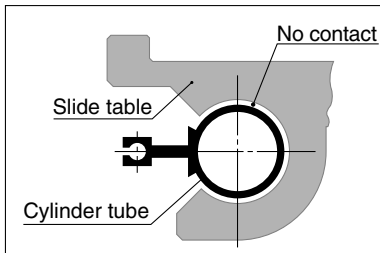

Special cylinder tube Long stroke (Max. 700 mm)

A special cylinder tube using extruded aluminum material is employed. No deflection or contact occurs even for long strokes, since the cylinder is rigidly attached to the base and the slide table is independently supported by a linear guide.

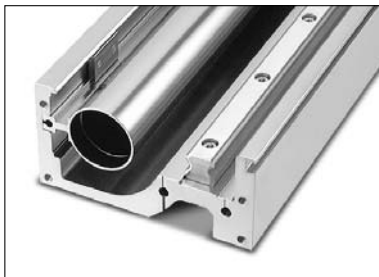

Low particulate generation

2

Stainless steel linear guide &

low particulate generation vacuum grease

Particulate generation from the linear guide unit has been reduced with the use of a stainless steel linear guide and low particulate generating vacuum grease.

Low particulate generation

3

Reduced initial particulate generation

Cleaned, assembled, inspected and first-stage packaged in a clean environment.

Low particulate generation

4

Low particulate generation at the stroke ends

Particulate generation has been reduced at the stroke ends by reducing impact using a sine cushion and by stopping the stroke using an internal stopper.

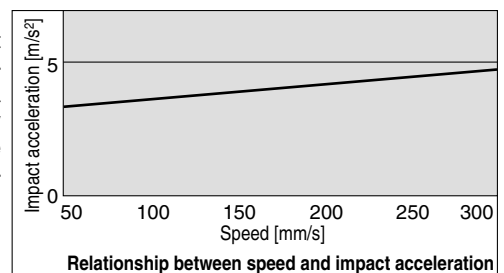

Relationship between speed and impact acceleration

in vacuum environments (1.3×10^{-4} Pa)

low leakage, and low outgassing.

Low leakage

Leakage: 1.3×10^{-7} Pa·m³/sec or less
(at normal temperatures, excluding gas permeation)

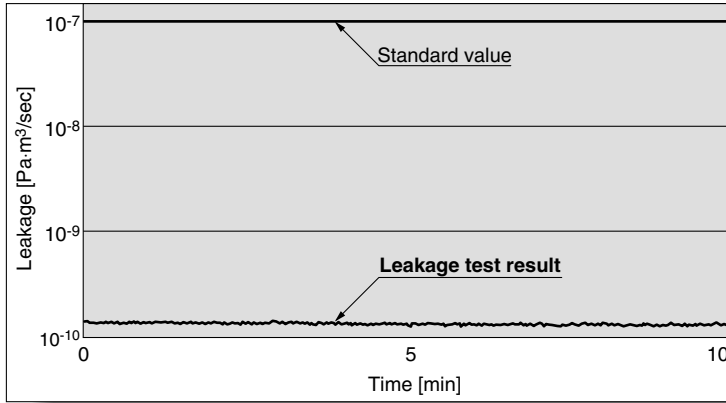

Note 1) The data indicates the leakage measured in a vacuum environment of 10^{-5} Pa.

Note 2) The leakage test result shown is based on a test conducted for 10 minutes after the cylinder was pressurized with helium at 0.1 MPa.

Note 3) This data is considered typical but not guaranteed.

Low leakage
1

Employs a magnetically coupled rodless cylinder with no air leakage from moving parts

Low leakage
2

O-ring seals separate vacuum and atmosphere

Static O-ring seals are used for all the seals between vacuum and atmosphere.

Note 1) The chart above shows the leakage test results based on a test conducted using this cylinder construction.

Note 2) To allow fine stroke adjustments, O-ring seals are installed to separate vacuum and atmosphere. Please consult with SMC if the sealing method needs to be altered.

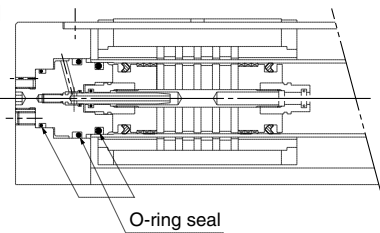

Reduced outgassing

Reduced outgassing
1

Reduction of outgassing due to surface treatment

All the external parts (made of aluminum alloy) such as the body and slide table are electroless nickel plated.

Furthermore, external magnets are coated with titanium nitride.

Note 1) Please consult with SMC if other specifications for surface treatment are required.

Reduced outgassing
2

Resin materials eliminated

Laser marking is employed for the model designation.

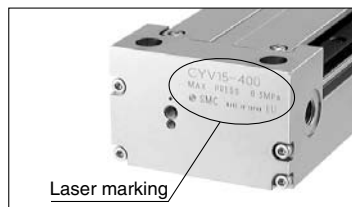

Fine adjustments at the end of the stroke

Fine adjustments between -2 to 0 mm can be made on one side (-4 to 0 mm for both sides).

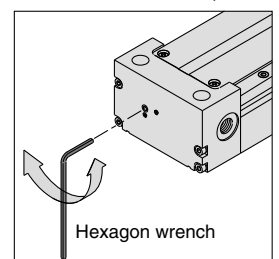

XL□

XL□Q

XM□
XY□

D-□

XVD

XGT

CVY

Series CYV Model Selection 1

Caution on Design (1)

The allowable load mass moment differs depending on the workpiece mounting method, cylinder mounting orientation and piston speed.
To determine whether or not the cylinder can be operated, do not allow the sum ($\sum \alpha_n$) of the load factors (α_n) for each mass and moment to exceed "1".

$$\sum \alpha_n = \frac{\text{Load mass (m)}}{\text{Max. load mass (m max)}} + \frac{\text{Static moment (M)}}{\text{Allowable static moment (M max)}} + \frac{\text{Dynamic moment (Me)}}{\text{Allowable dynamic moment (Me max)}} \leq 1$$

Load Mass

Max. load mass (kg)

Model	m max
CYV15	1
CYV32	5

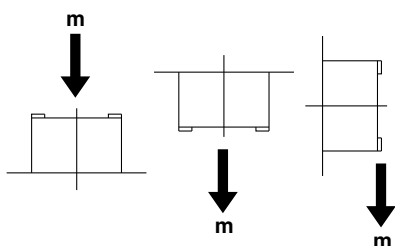

Moment

Allowable moment
(Static moment/Dynamic moment)

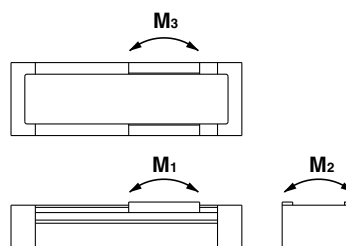

Model	M1	M2	M3
CYV15	0.3	0.6	0.3
CYV32	3	4	3

(N-m)

Static Moment

Moment generated by the workpiece weight even when the cylinder is stopped

■ Pitch moment

$$M_1 = m \times g \times (L + B) \times 10^{-3}$$

■ Roll moment

$$M_2 = m \times g \times (L + B) \times 10^{-3}$$

■ Yaw moment

$$M_3 = m \times g \times (L + A) \times 10^{-3}$$

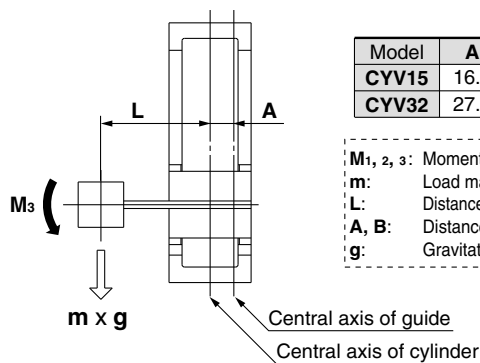
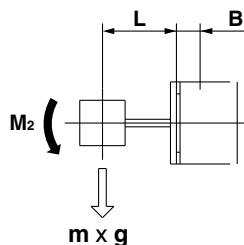
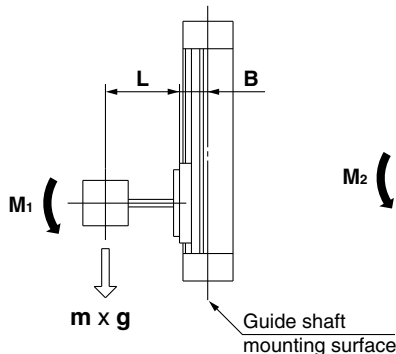

Model	A	B
CYV15	16.5	25.5
CYV32	27.0	48.0

(mm)

M_{1, 2, 3}: Moment [N·m]
m: Load mass [kg]
L: Distance to load center of gravity [mm]
A, B: Distance to guide shaft [mm]
g: Gravitational acceleration [9.8 m/s²]

Dynamic Moment

Moment generated by the load equivalent to impact at the stroke end

$$We = 5 \times 10^{-3} \times m \times g \times U$$

We: Load equivalent to impact [N]
m: Load mass [kg]

U: Max. speed [mm/s]
g: Gravitational acceleration [9.8 m/s²]

■ Pitch moment

$$Me_1 = 1/3 \cdot We (L + B) \cdot 10^{-3} *$$

* Average load coefficient

■ Yaw moment

$$Me_3 = 1/3 \cdot We (L + A) \cdot 10^{-3} *$$

* Average load coefficient

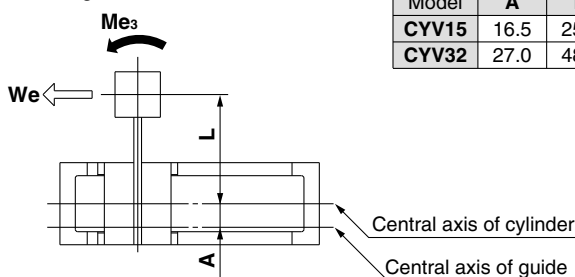
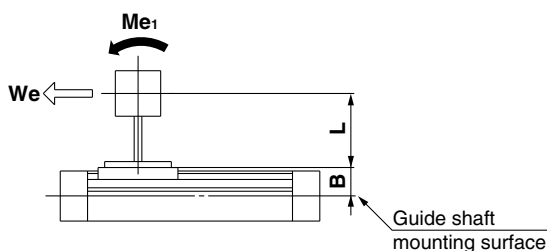

Model	A	B
CYV15	16.5	25.5
CYV32	27.0	48.0

(mm)

Series CYV

Model Selection 2

Selection Calculation

The selection calculation finds the load factors (α_n) of the items below, where the total ($\sum \alpha_n$) does not exceed "1".

$$\sum \alpha_n = \alpha_1 + \alpha_2 + \alpha_3 \leq 1$$

Item	Load factor α_n	Note
1 Max. load mass	$\alpha_1 = m/m \text{ max}$	Review m . $m \text{ max}$ is the maximum load mass.
2 Static moment	$\alpha_2 = M/M \text{ max}$	Review M_1, M_2, M_3 . $M \text{ max}$ is the allowable moment.
3 Dynamic moment	$\alpha_3 = Me/Me \text{ max}$	Review Me_1, Me_3 . $Me \text{ max}$ is the allowable moment.

Calculation Example

Operating Conditions

Cylinder: CYV32
 Mounting: Horizontal wall mounting
 Maximum speed: $U = 300$ [mm/s]
 Load mass: $m = 1$ [kg] (excluding mass of the arm section)
 $L_1 = 50$ [mm]
 $L_2 = 50$ [mm]

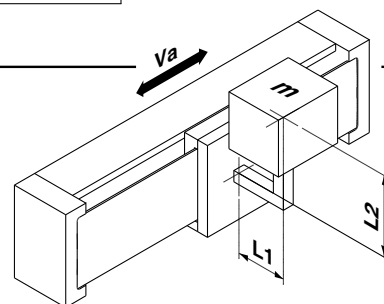

XL

XLQ

XM
 XY

D-

XVD

XGT

CYV

Item	Load factor α_n	Note
1 Maximum load mass 	$\alpha_1 = m/m \text{ max}$ $= 1/5$ $= 0.20$	Review m .
2 Static moment 	$M_2 = m \cdot g \cdot (L_1 + B) \cdot 10^{-3}$ $= 1 \cdot 9.8 \cdot (50 + 48) \cdot 10^{-3}$ $= 0.96$ [N·m] $\alpha_2 = M_2/M_2 \text{ max}$ $= 0.96/4$ $= 0.24$	Review M_2 . Since M_1 and M_3 are not generated, review is unnecessary.
3 Dynamic moment 	$We = 5 \times 10^{-3} \cdot m \cdot g \cdot U$ $= 5 \times 10^{-3} \cdot 1 \cdot 9.8 \cdot 300$ $= 14.7$ [N] $Me_3 = 1/3 \cdot We \cdot (L_2 + A) \cdot 10^{-3}$ $= 1/3 \cdot 14.7 \cdot (50 + 27) \cdot 10^{-3}$ $= 0.38$ [N·m] $\alpha_{3a} = Me_3/Me_3 \text{ max}$ $= 0.38/3$ $= 0.13$	Review Me_3 .
	$Me_1 = 1/3 \cdot We \cdot (L_1 + B) \cdot 10^{-3}$ $= 1/3 \cdot 14.7 \cdot (50 + 48) \cdot 10^{-3}$ $= 0.48$ [N·m] $\alpha_{3b} = Me_1/Me_1 \cdot \text{max}$ $= 0.48/3$ $= 0.16$	Review Me_1 .

$$\begin{aligned} \sum \alpha_n &= \alpha_1 + \alpha_2 + (\alpha_{3a} + \alpha_{3b}) \\ &= 0.20 + 0.24 + (0.13 + 0.16) \\ &= 0.73 \end{aligned}$$

The result $\sum \alpha_n = 0.73 \leq 1$ allows operation.

Series CYV Model Selection 3

Caution on Design (2)

Table Deflection Note)

Table deflection due to pitch moment load

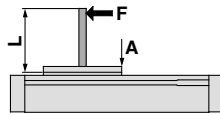

$$M_1 = F \times L$$

Table deflection due to roll moment load

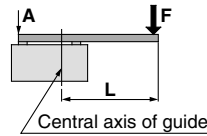

$$M_2 = F \times L$$

Table deflection due to yaw moment load

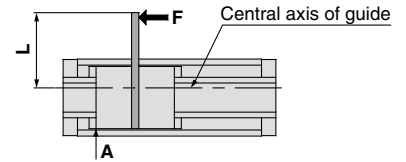

$$M_3 = F \times L$$

Note) Deflection: Displacement of point A when force acts on point F
Point A: Indicates a measurement point

CYV15 (M₁)

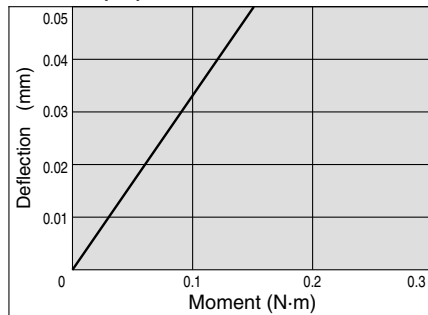

CYV15 (M₂)

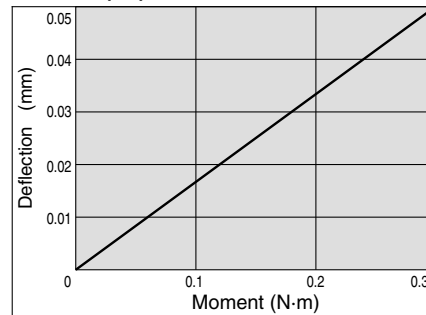

CYV15 (M₃)

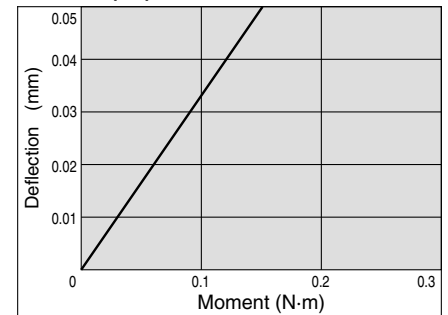

CYV32 (M₁)

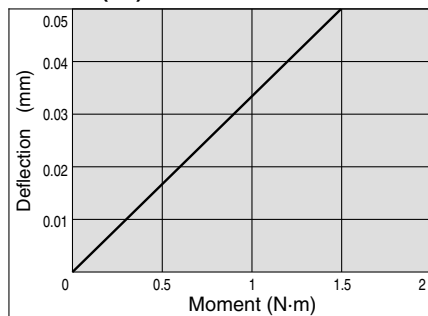

CYV32 (M₂)

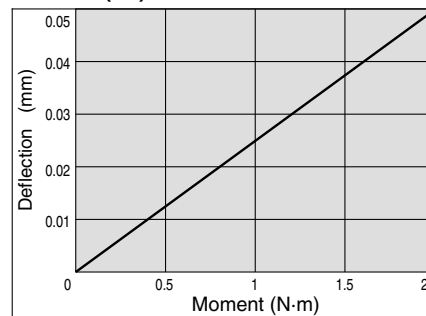

CYV32 (M₃)

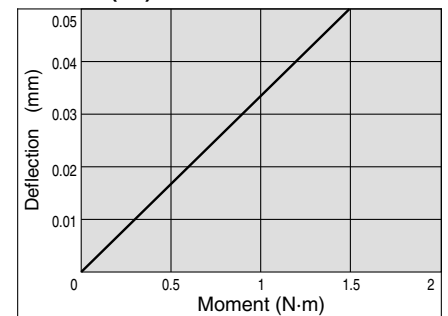

Note) Extend the graph line for the deflection, if a moment other than those given above is applied.

Vertical Operation

When using in vertical operation, prevention of workpiece dropping due to breaking of the magnetic coupling should be considered. The allowable load mass and maximum operating pressure should be as shown in the table below.

Model	Allowable load mass mv (kg)	Maximum operating pressure Pv (MPa)
CYV15	1	0.3
CYV32	5	

Intermediate Stop

The cushion effect (smooth start-up, soft stop) is applied only before the stroke end in the stroke ranges indicated in the table below.

The cushion effect (smooth start-up, soft stop) is not available an intermediate stop or return from an intermediate stop using an external stopper, etc.

When using an intermediate stop with the above information taken into account, implement measures to prevent particulate generation and set the operating pressure to no more than 0.3 MPa.

Cushion Stroke

Model	Stroke (mm)
CYV15	25
CYV32	30

Rodless Cylinder for Vacuum

Series *CYV*

How to Order

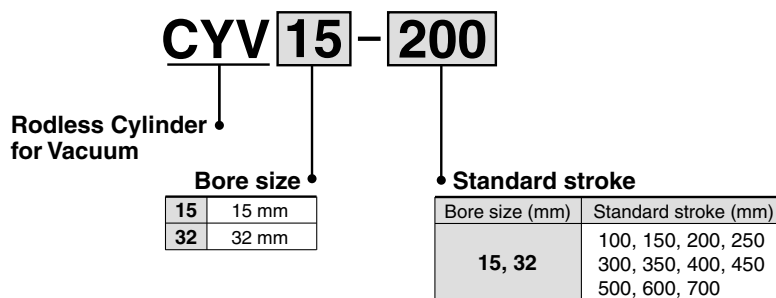

- XL
- XLQ
- XM
- XY
- D-
- XVD
- XGT
- CYV**

Specifications

Bore size (mm)	15	32
Operating environment pressure	Atmosphere to 1.3×10^{-4} Pa (ABS)	
Operating atmosphere <small>Note 1)</small>	Air/Inert gas	
Fluid <small>Note 1)</small>	Air/Inert gas	
Action	Double acting	
Proof pressure	0.5 MPa	
Operating pressure range	0.05 to 0.3 MPa	
Leakage	1.3×10^{-7} Pa·m ³ /sec or less (at normal temperatures, excluding gas permeation)	
Maximum baking temperature <small>Note 2) Note 3)</small>	100°C	
Ambient and fluid temperature	-10 to 60°C	
Piston speed (MAX.) <small>Note 4)</small>	50 to 300 mm/s	
Stroke adjustment	-2 to 0 mm on each side (-4 to 0 mm total)	
Cushion	Sine cushion (Air cushion)	
Port size	5/16-24 UNF	7/16-20 UNF
Lubrication	Vacuum grease for linear guide unit and inside the cylinder tube	

Note 1) Air is recommended as the operational atmosphere and fluid, but contact SMC if other inert gasses are used, as the product life may change.

Note 2) Baking is limited to baking before cylinder operation. Cylinder operation should be with a temperature range of -10 to 60°C.

Note 3) Contact SMC if the baking temperature will exceed 100°C.

Note 4) The piston speed listed above is the maximum piston speed. When the slide table on the stroke edge starts moving, it will take approximately 0.5 seconds (each end) or 1 second (both ends) to slip out of the cushion stroke.

Mass

Model	Standard stroke (mm)										
	100	150	200	250	300	350	400	450	500	600	700
CYV15	1.2	1.4	1.6	1.7	1.9	2.0	2.2	2.4	2.5	2.8	3.2
CYV32	4.2	4.6	5.0	5.5	5.9	6.3	6.7	7.1	7.5	8.3	9.1

(kg)

Magnetic Holding Force

Bore size (mm)	Magnetic holding force (N)
15	59
32	268

Theoretical Output

Bore size (mm)	Piston area (mm ²)	Operating pressure (MPa)		
		0.1	0.2	0.3
15	176	18	35	53
32	804	80	161	241

(N)

Series CYV

Construction

CYV15

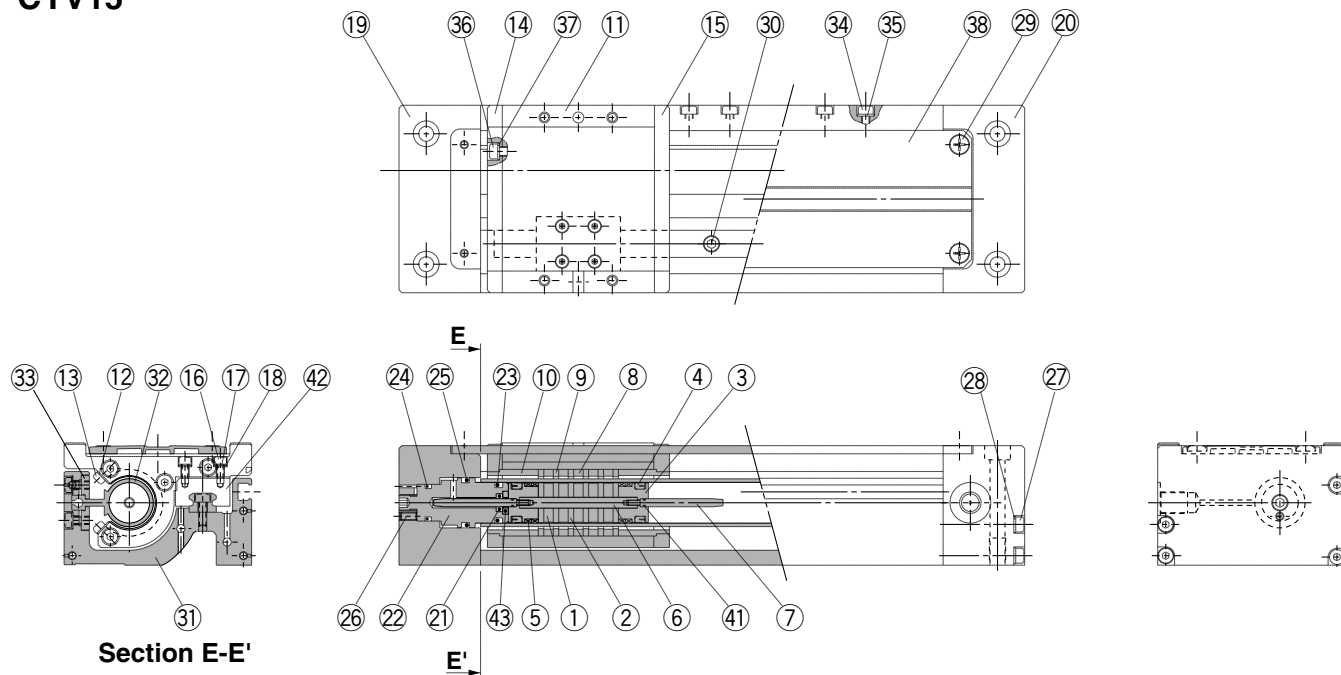

CYV32

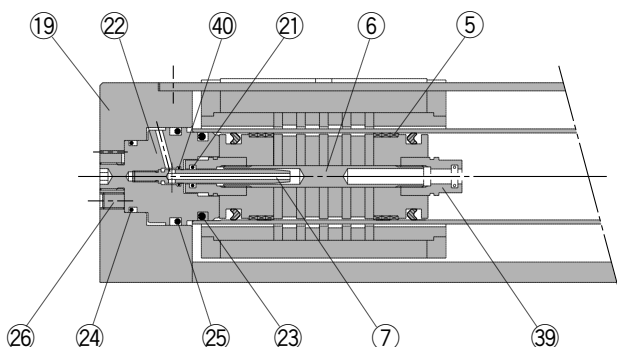

Component Parts

No.	Description	Material	Note
1	Magnet A	—	
2	Piston side yoke	Rolled steel plate	Zinc chromated
3	Piston	Brass/ Aluminum alloy	Electroless nickel plated/Chromated
4	Piston seal	Fluororubber	
5	Wear ring	Special bearing	
6	Shaft	Stainless steel	
7	Cushion ring	Stainless steel/Brass	—/Electroless nickel plated
8	Magnet B	—	Titanium nitride coating
9	External slider side yoke	Rolled steel	Electroless nickel plated
10	Hold spacer	Aluminum alloy	Electroless nickel plated
11	Slide table	Aluminum alloy	Electroless nickel plated
12	Insertion guide plate	Stainless steel	
13	Round head Phillips screw	Stainless steel	
14	Side plate A	Aluminum alloy	Electroless nickel plated
15	Side plate B	Aluminum alloy	Electroless nickel plated
16	Hexagon socket head cap screw	Stainless steel	
17	Spring washer	Stainless steel	
18	Flat washer	Stainless steel	
19	Plate A	Aluminum alloy	Electroless nickel plated
20	Plate B	Aluminum alloy	Electroless nickel plated
21	Cushion seal	Fluororubber	

No.	Description	Material	Note
22	Inner cover	Aluminum alloy	Electroless nickel plated
23	Cylinder tube gasket	Fluororubber	
24	O-ring	Fluororubber	
25	O-ring	Fluororubber	
26	Hexagon socket head set screw	Stainless steel	
27	Hexagon socket head cap screw	Stainless steel	
28	Flat washer	Stainless steel	
29	Round head Phillips screw	Stainless steel	
30	Hexagon socket head cap screw	Stainless steel	
31	Base	Aluminum alloy	Electroless nickel plated
32	Cylinder tube	Aluminum alloy	Electroless nickel plated
33	Tube attaching bracket	Aluminum alloy	Electroless nickel plated
34	Hexagon socket head cap screw	Stainless steel	
35	Flat washer	Stainless steel	
36	Hexagon socket head cap screw	Stainless steel	
37	Flat washer	Stainless steel	
38	Top cover	Aluminum alloy	Electroless nickel plated
39	Cushion seal holder	Aluminum alloy	Chromated
40	O-ring	Fluororubber	
41	O-ring	Fluororubber	
42	Linear guide	Stainless steel	
43	Retaining plate	Aluminum alloy	Hard anodized

Note) In the material and note columns of the Component Parts list above, the first description is for CYV15 and the second description is for CYV32.

Dimensions

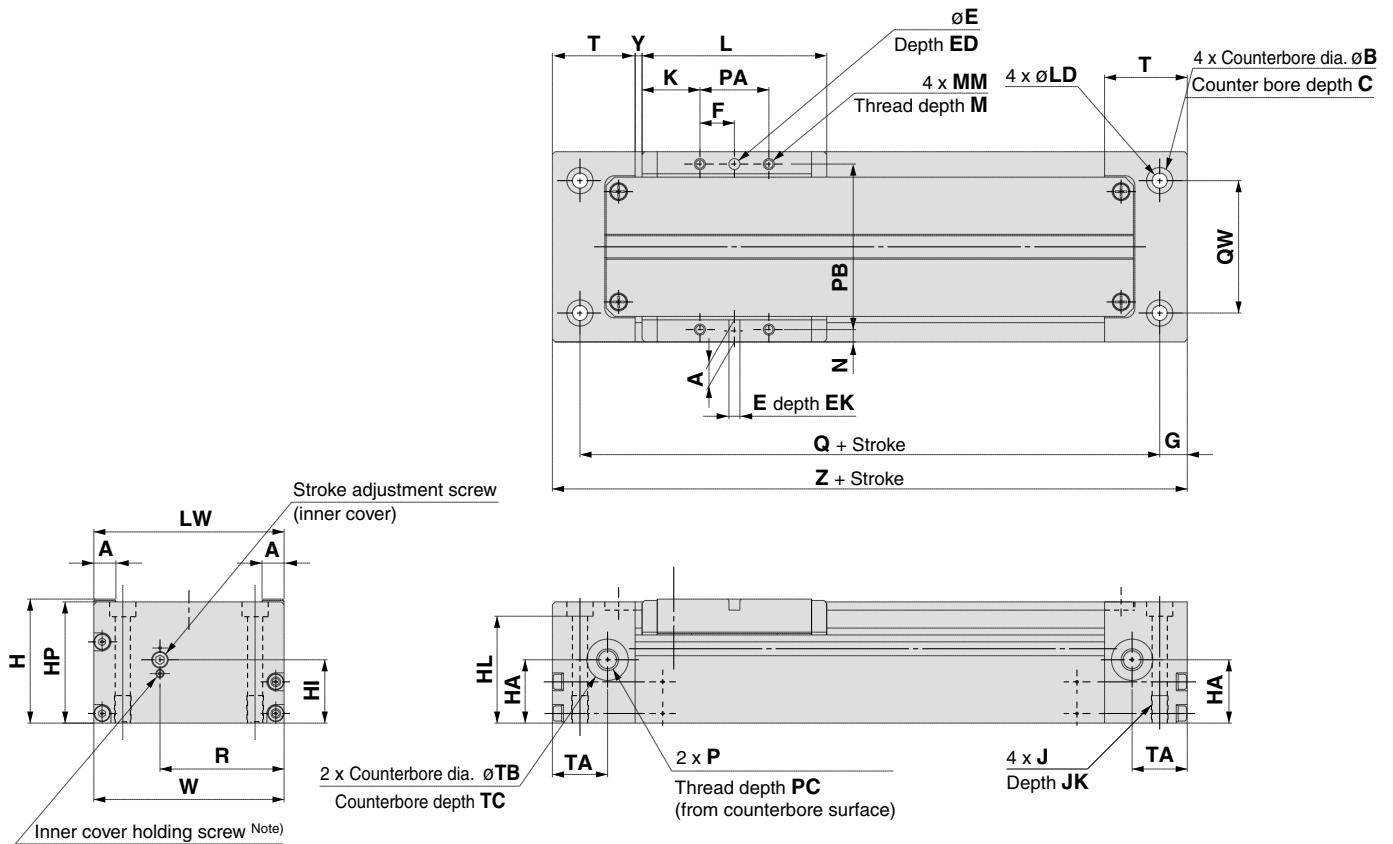

XL

XLQ

XM

XY

D-

XVD

XGT

CYV

Model	A	B	C	E	ED	EK	F	G	H	HA	HI	HL	HP	J	JK	K	L	LD
CYV15	8	10.5	6.4	$4_{H9}^{+0.030}$	9.5	4	12.5	10	45	23	23	37.6	44	M6 x 1	10	21	67	5.6
CYV32	12	16	10.2	$6_{H9}^{+0.030}$	13	6	25	9	75	39	39	63.3	73.5	M10 x 1.5	12	20	90	9.2

Model	LW	MM	M	N	P	PA	PB	PC	Q	QW	R	T	TA	TB	TC	W	Y	Z
CYV15	69	M4 x 0.7	6	4.5	5/16-24 UNF	25	60	10	112	48	45	30	20	15	0.5	69	2.5	132
CYV32	115	M6 x 1	8	7.5	7/16-20 UNF	50	100	12	147	83	79.5	34	22.5	20	0.5	115	3.5	165

Note) Refer to "Cushion Effect (Sine Cushion) and Stroke Adjustment" under Specific Product Precautions on page 129.



Series CYV Specific Product Precautions 1

Be sure to read before handling.
Refer to front matters 30 and 31 for Safety Instructions.

Handling

⚠ Caution

1. Open the inner package of the double packaged clean series product inside a clean room or other clean environment.
2. Do not install a cylinder with bare hands. Outgassing characteristics can be degraded.
3. Perform parts replacement and disassembly work inside the chamber after exhausting compressed air in the piping to the outside of the clean room.

Mounting

⚠ Caution

1. Take care to avoid striking the cylinder tube with other objects or handling it in a way that could cause deformation.

The cylinder tube and slider units have a non-contact construction. For this reason, even a slight deformation or slippage of position can cause malfunction and loss of durability, as well as a danger of degrading particulate generation characteristics.

2. Do not scratch or gouge the linear guide by striking it with other objects.
3. Since the slide table is supported by precision bearings, do not apply strong impacts or excessive moment when mounting workpieces.
4. The cylinder can be operated by directly applying a load within the allowable range. However, careful alignment is necessary when connecting to a load with an external guide mechanism.

Since displacement of the alignment increases as the stroke becomes longer, consider a connection method that can absorb the displacement and does not cause interference at any point within the stroke. Also, operate with due consideration of measures against particulate generation.

5. Never loosen the bolt holding the linear guide block and slide table.
6. It is recommended that the load center of gravity is set on top of the linear guide.

The linear guide position is offset from the cylinder's central axis, and if the cylinder's central axis becomes the load center of gravity, moment is applied to the cylinder and this will lower the tolerance.

7. Be sure to operate the cylinder with the plates on both sides secured.

Avoid applications in which the slide table or only one plate is secured.

8. Do not use until you verify that the equipment can be operated properly.

After mounting or repair, connect the air supply and electric power, and then confirm proper mounting by performing appropriate function and leakage tests.

Operation

⚠ Caution

9. Instruction manual

Mount and operate the product after thoroughly reading the manual and understanding its contents. Also, store it where it can be referred to at any time.

Operation

⚠ Caution

1. The maximum operating pressure for the vacuum rodless cylinder is 0.3 MPa.

If the maximum operating pressure of 0.3 MPa for the vacuum rodless cylinder is exceeded, the magnetic coupling can be broken, causing a danger of malfunction or degradation of particulate generation characteristics, etc.

2. When used for vertical operation, take precautions against possible dropping due to separation of the magnetic coupling.

When used for vertical operation, use caution as there is a possibility of dropping due to separation of the magnetic coupling if a load (pressure) greater than the allowable value is applied.

3. Do not operate with the magnetic coupling out of position.

If the magnetic coupling is out of position, push the external slider (or the piston slider by using air pressure) back to the proper position at the stroke end. (When pushing the external slider, do not push it with bare hands.)

4. Do not apply lubricant, as this is a non-lube product.

The interior of the cylinder is lubricated at the factory, and lubrication with turbine oil, etc., will not satisfy the product's specifications.

5. Contact SMC if greasing the linear guide.

If grease is applied to the linear guide, particle generation will increase temporarily. However, regular greasing is recommended.

6. Use the cylinder in inert gas environments.

Corrosive gases may cause corrosion of a cylinder and loss of durability.

7. Be sure to use the cylinder in pressure environments from atmosphere to 1.3×10^{-4} Pa (ABS).

If used in pressure environments below these conditions, grease applied to the guide unit will evaporate excessively and may cause environmental contamination and loss of durability.

8. Be sure to set the baking temperature (only before the cylinder operates) to 100°C or less.

If a higher temperature is used, the grease will evaporate excessively and may cause environmental contamination and loss of durability.

9. Positioning of a cylinder should be performed using an optical sensor from outside the chamber.

A positioning sensor cannot be mounted on the cylinder.

10. Using extremely dry air as a fluid will affect the reliability (life) of the device, such as deteriorating the lubrication characteristics of the interior, so contact SMC and check.



Series CYV Specific Product Precautions 2

Be sure to read before handling.
Refer to front matters 30 and 31 for Safety Instructions.

Fitting

⚠ Caution

1. A fitting with an O-ring is used for a high vacuum rodless cylinder.

Use a fitting that conforms to the dimensions below, and install it so that there is no air leakage.

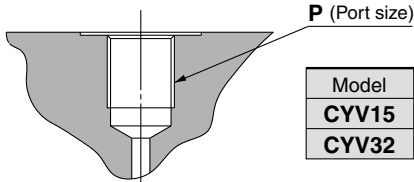

2. Air blow and clean fittings and piping materials completely with clean air to remove oil and impurities, etc., before piping.

Speed Adjustment

⚠ Caution

1. A speed controller for clean room use is recommended for speed adjustment.
2. Install the speed controller outside the chamber.
3. In case of vertical mounting, a system with a regulated supply circuit installed on the down side is recommended. (This is effective against delays at the start of upward movement and for conservation of air.)

Cushion Effect (Sine Cushion) and Stroke Adjustment

⚠ Caution

1. A sine cushion (smooth start-up, soft stop) function is included in the standard specifications.

Due to the nature of a sine cushion, adjustment of the cushion effect is not possible. There is no cushion needle adjustment as in the case of conventional cushion mechanisms.

2. The stroke adjustment is a mechanism to adapt the slide table's stroke end position to a mechanical stopper on other equipment, etc.

(Adjustment range: Total of both sides -4 to 0 mm)

To ensure safety, perform adjustment after shutting off the drive air, releasing the residual pressure and implementing drop prevention measures, etc.

- 1) Loosen the inner cover holding screw with a hexagon wrench. (When adjusting the stroke, always loosen this holding screw first. If the stroke adjustment screw is turned before the holding screw is loosened, the adjustment screw's hexagonal hole will change shape and stroke adjustment will become impossible)
- 2) By turning the inner cover's stroke adjustment screw with the hexagon wrench, the inner cover is moved back and forth in an axial direction, in order to align it with devices such as mechanical stoppers. (Stroke adjustment screw part's turn direction: left rotation → +stroke/right rotation → -stroke)

Cushion Effect (Sine Cushion) and Stroke Adjustment

⚠ Caution

- 3) The maximum adjustment on one side is -2 to 0 mm. A total adjustment of approximately -4 to 0 mm is possible using both sides.
- 4) After completing the stroke adjustment, tighten the inner cover holding screw with a hexagon wrench, etc.

Inner Cover Holding Screw Tightening Torques [N·m] and Hexagon Wrench

Model	Inner Cover Holding Screw			Stroke adjustment screw
	Screw size	Tightening torque	Hexagon wrench (nominal)	Hexagon wrench (nominal)
CYV15	M3 x 0.5	0.3	1.5	2.5
CYV32	M6 x 1	2.45	3	4

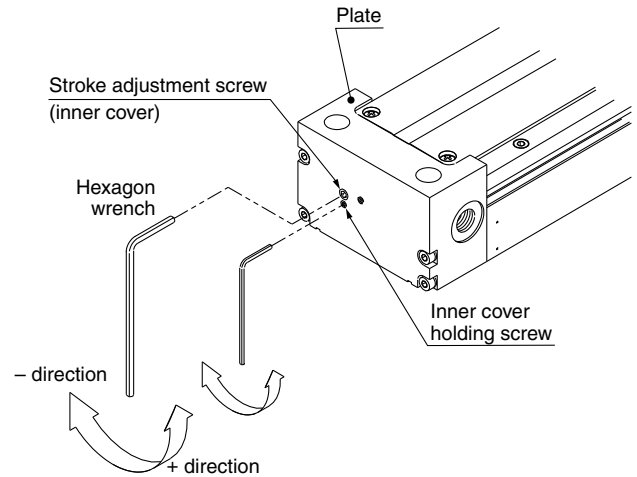

Maintenance

⚠ Caution

1. Never disassemble the cylinder tube or linear guide, etc.

If disassembled, the slide table may touch the outside surface of the cylinder tube resulting in a degradation of particulate generation characteristics.

2. Please consult with SMC when replacing seals and bearings (wear rings).
3. Cylinder maintenance should be performed after an operation of 1 million cycles, or a length of 200 km.

XL□

XL□Q

XM□

XY□

D-□

XVD

XGT

CYV



Series CYV Specific Product Precautions 3

Be sure to read before handling.
Refer to front matters 30 and 31 for Safety Instructions.

Particulate Generation Characteristics

Caution

1. In order to maintain the particulate generation grade, use operation of 1 million cycles or travel distance of about 200 km as a guide. (Table (1) below)

If operation is continued beyond the recommended values, lubrication failure of the linear guide and a degradation of particulate generation characteristics may occur.

Contact SMC if you intend to perform operation beyond the recommended values.

Table (1)

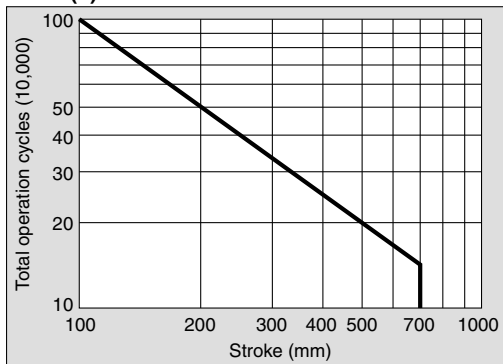

2. Regular greasing is recommended if grease for the linear guide section runs low because of the operating situation.

However, particle generation will increase temporarily in the above case. The increased particle generation will lower gradually if operation continues for a while.